

US  
Version



Revision: 1.10 Year: 2021



# Fitting and Service Manual

iCLASS FP

iCLASS S

iCLASS SP



A Get the app & manual

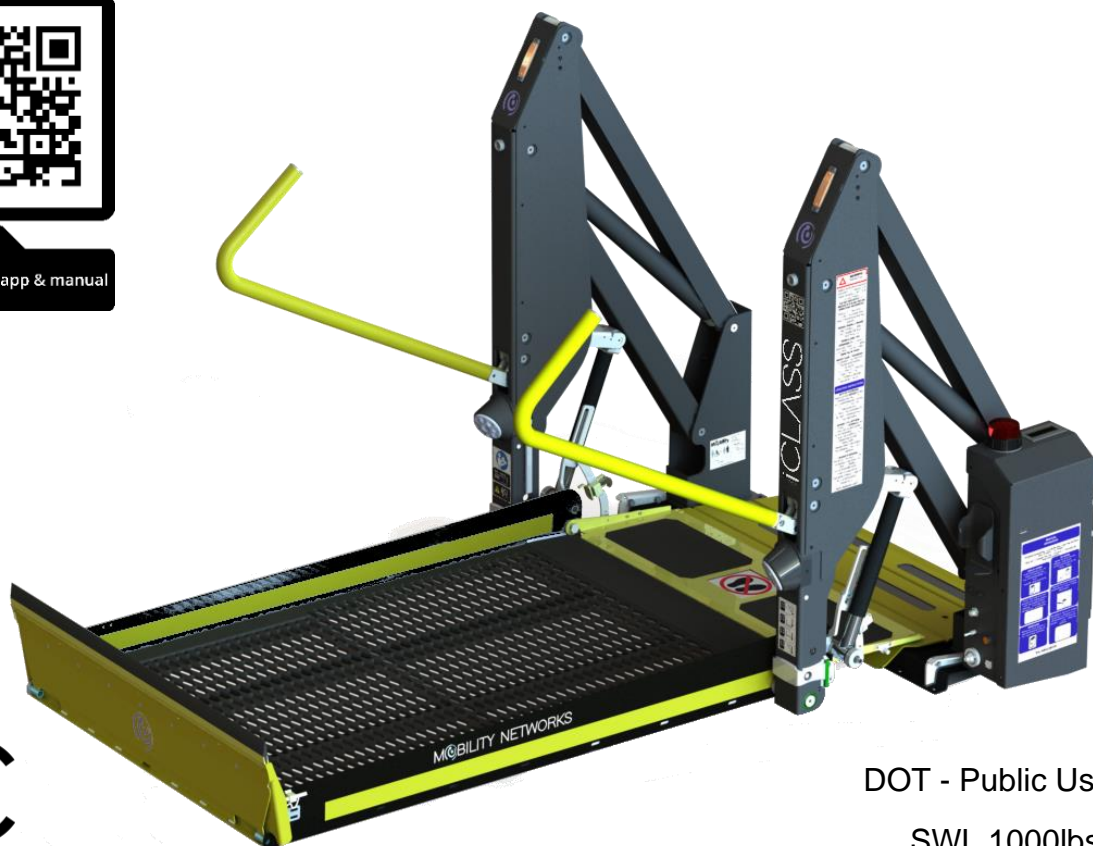

DOT - Public Use Lift

SWL 1000lbs

DOT-Public Use Lift verifies that this platform lift meets the Public Use Lift requirements of FMVSS No. 403. This lift may be installed on all vehicles appropriate for the size and weight of the lift, but must be installed on buses, school buses, and multi-purpose passenger vehicles other than motor homes with a gross vehicle weight rating (GVWR) that exceeds (4,536 kg) 10,000 lb.

## Revision Status

REVISION	DATE	NOTE
0	FEBRUARY 2020	ORIGINAL VERSON
1	FEBRUARY 2020	CONTENT UPDATE
1.2	MARCH 2020	CONTENT UPDATE
1.3	JULY 2020	CONTENT UPDATE
1.4	NOV 2020	CONTENT UPDATE
1.5	NOV 2020	SAFETY UPDATE
1.6	DEC 2020	CONTENT UPDATE
1.7	DEC 2020	CONTENT UPDATE
1.8	FEB 2021	CONTENT UPDATE
1.9	JULY 2021	CONTENT UPDATE
1.10	JULY 2021	CONTENT UPDATE

 **WARNING:** The Lift may be packaged and shipped **WITHOUT** Safety Handrails.

Handrail type should be selected and correctly installed **BEFORE** the first operation of the lift.

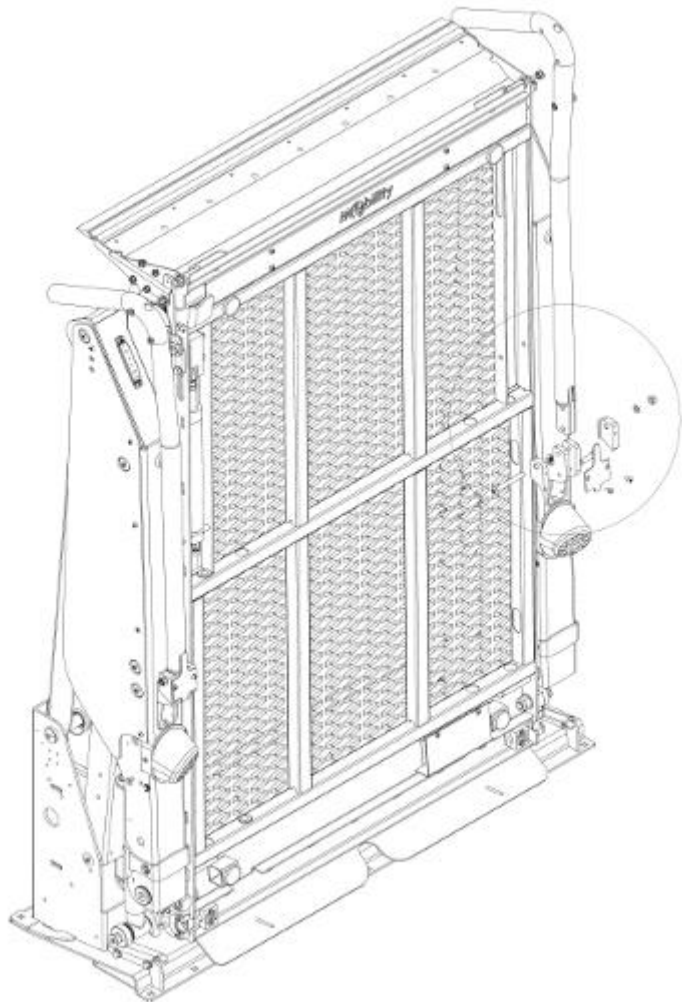

Correct installation should be carried out by an approved engineer.

See SECTION 5.5 for installation details.

<b>1 General .....</b>	<b>7</b>
1.1 Manufacturer.....	7
1.2 Safety Rules and Symbols .....	7
1.3 Using the Manual.....	9
1.4 Documentation.....	10
1.5 IMPORTANT Wheelchair Integrated Occupant Seatbelts .....	10
1.6 Lift Owner and Lift Operator .....	11
1.7 Connectivity .....	12
<b>2 Warnings .....</b>	<b>13</b>
2.1 Genuine Spare Parts .....	14
<b>3 Technical.....</b>	<b>15</b>
3.1 Technical Description .....	15
3.2 iCLASS Model Types .....	17
3.3 Technical Specifications.....	18
3.4 Safety Devices.....	19
3.4.1 Doorsafe .....	20
3.4.2 mobility RDO REAR DOOR OPENER .....	20
3.5 iCLASS Accessibility.....	21
3.6 Minimum Operating Volume.....	22
<b>4 Logistics.....</b>	<b>23</b>
4.1 Transport and movement .....	23
4.2 Packaging .....	25
4.3 Storage.....	25
<b>5 Fitting and Installation.....</b>	<b>26</b>
5.1 Dimensions .....	26
5.2 iCLASS Lift Fitting Kit .....	28
5.3 Lift positioning and fixing .....	30
5.4 Correcting the angle of the towers .....	34
5.5 Fitting Safety Handrails .....	35
5.6 Fitting Handrail Safety Belt.....	36
<b>6 Electrical.....</b>	<b>37</b>



6.1 Power Supply.....	37
6.2 Door Interlock.....	40
6.3 Operation Procedure and Backup Operations.....	41
<b>7 Power Pack .....</b>	<b>42</b>
7.1 Power Pack.....	42
7.2 Hydraulic Oil level check and top-up.....	43
7.3 Hydraulic Pressure Control .....	44
7.4 Pressure Control Switches .....	44
7.5 Pressure Control Switch Adjustment .....	45
<b>8 Commissioning .....</b>	<b>47</b>
8.1 Lift Position Setting .....	48
8.2 iCLASS Weight Test Certificate .....	51
8.3 Maintenance Schedule – Important Information.....	54
8.4 ECU and the Mobility Networks – Smart Lift App.....	55
8.5 Installing the Mobility Networks – Smart Lift App and Pairing to the ECU.....	55
8.6 Mobility Networks – Smart Lift App DEBUG Mode and Installer ECU Tools.....	56
8.7 Changing from ‘Safety Mode’ to ‘Full Operation Mode’ .....	57
8.8 ECU Details .....	57
8.9 Commissioning Log .....	58
<b>9 Operation.....</b>	<b>60</b>
9.1 Operation Introduction.....	60
9.2 Standard Operation .....	63
9.3 Lift Handle Safety Belt.....	66
9.4 Emergency Operation.....	66
<b>10 Reference Material .....</b>	<b>69</b>
10.1 Torque Settings .....	69
10.2 Fastener Strength Conversion Chart .....	70
10.3 Electrical Schematic – iCLASS S.....	71
10.5 iCLASS Deployment Gap Schematic.....	75
10.6 iCLASS S Hydraulic Schematic .....	77
10.7 iCLASS SP Hydraulic Schematic .....	78
10.8 iCLASS FP Hydraulic Schematic .....	79
10.9 Hydraulic Routing .....	80
<b>11 ECU .....</b>	<b>81</b>
11.1 Setting ‘Full Operation Mode’ (non-Mobility Networks – Smart Lift App method) .....	81
11.2 Electrostatic Precautions.....	82

11.3 Firmware Updates .....	83
11.4 Firmware Update using the Mobility Networks App.....	84
11.5 ECU Pin Configurations .....	85
11.6 RTC - Battery Replacement.....	86
11.7 ECU Display Messages.....	87
<b>12 Inspection and Servicing .....</b>	<b>89</b>
12.1 Service Intervals .....	90
12.2 Daily Checks.....	90
12.3 Checks to be performed every 2 Weeks.....	91
12.4 Service Type A .....	91
12.5 Service Type B .....	93
12.6 Service Type C .....	94
12.7 Outer Barrier Cylinder Check .....	95
12.8 Set lift to work height .....	95
12.9 Outer Barrier Cylinder Replacement.....	96
12.10 Service Type D .....	97
12.10.1 Replace Arm Pivot Pin .....	97
12.10.2 Replace Inner Barrier Locks.....	98
12.10.3 Oil Check and Change .....	99
12.11 iCLASS Workshop Manual: Arm Cylinder Replacement.....	99
12.12 iCLASS Workshop Manual: Arm Gas Spring Replacement.....	101
12.13 iCLASS Workshop Manual: Safety Handrail Gas Spring Replacement .....	102
12.14 iCLASS Workshop Manual: Safety Hook Replacement.....	103
12.15 iCLASS Workshop Manual: Power Pack Replacement .....	104
12.16 iCLASS Workshop Manual: ECU Removal .....	105
12.17 iCLASS Workshop Manual: ECU Cover Removal .....	106
12.18 iCLASS Workshop Manual: Threshold Warning Mat Adjustment.....	106
12.19 iCLASS Workshop Manual: Rotary Switch Replacement .....	107
12.20 iCLASS Workshop Manual: Platform Levelling .....	108
12.21 iCLASS Workshop Manual: Outer Barrier Check and Adjustment .....	110
(iCLASS S and SP only) .....	110
12.22 iCLASS Workshop Manual: Platform Stow Check and Adjustment.....	111
12.23 iCLASS Workshop Manual: Inner Barrier Check and Adjustment.....	112
12.24 iCLASS Workshop Manual: Handrail Safety Belt Installation .....	114
<b>13 Cleaning .....</b>	<b>116</b>

<b>14 Lubrication .....</b>	<b>117</b>
<b>15 Inspection and Servicing .....</b>	<b>118</b>
15.1 Inspection and Service Data Sheet.....	118
<b>16 Troubleshooting .....</b>	<b>119</b>
16.1 Switch Locations.....	123
<b>17 iCLASS Labelling.....</b>	<b>124</b>
17.1 Lift Labelling.....	124
17.2 Power Pack Labels - Inside.....	124
17.3 Power Pack Labels - Outside.....	125
<b>18 iCLASS S Spares .....</b>	<b>126</b>
18.1 iCLASS S Spares Summary.....	126

## 1.1 Manufacturer



Mobility Networks Holdings Ltd.  
 12 Estuary View Business Park  
 Whitstable  
 Kent, CT5 3SE  
 United Kingdom  
 Tel: +44(0) 1227 505 022

The iCLASS wheelchair lift, is manufactured by Mobility Networks Holdings Ltd.  
 (Mobility Networks)

The Mobility Networks iCLASS P and the VMI iCLASS S are the equivalent model of lift.  
 The iCLASS S name is used by VMI in North America for marketing purposes.

## 1.2 Safety Rules and Symbols



DOT-Public Use Lift verifies that this platform lift meets the Public Use Lift requirements of FMVSS No. 403. This lift may be installed on all vehicles appropriate for the size and weight of the lift, but must be installed on buses, school buses, and multi-purpose passenger vehicles other than motor homes with a gross vehicle weight rating (GVWR) that exceeds (4,536 kg) 10,000 lb.

Public use vehicle manufacturers are responsible for complying with the lift lighting requirements in Federal Motor Vehicle Safety Standard No. 404, Platform Lift Installations in Motor Vehicles (49 CFR 571.404).

Read this manual completely before commencing installation.  
 Particular care should be taken when these symbols are used:



**WARNING**

This symbol identifies the presence of instructions which need to be read and followed carefully in order to avoid potentially dangerous situations.



**DANGER**

This symbol identifies the presence of essential information needed to avoid potentially dangerous situations that could cause physical injuries and/or damage to the equipment.

**To ensure smooth and safe operation, it is necessary to follow the procedures for the installation and servicing of the wheelchair lift.**



**WARNING**

Carefully follow the instructions for the installation and service of the wheelchair lift within this manual. If the instructions within this manual have not been fully understood or further information is required, please contact Mobility Networks immediately. To avoid risk of personal injury, material damage to the equipment and vehicles or incorrect installation and use be sure to read and follow the contents of this manual.





**DANGER**

Should it be necessary to raise the vehicle being equipped, please check that the characteristics of the vehicle lifting device is compatible with the volume and weight of the actual vehicle otherwise there is a risk of serious damage and personal injury.



The Identification Plate, see Figure 1.2.1 is stamped with the data indicating the lift serial number. The Operator Manual requires these details to be recorded.

**NOTE: The Lift Serial number is required for ALL correspondence with factory**

		12 Estuary View Business Park Whitstable Kent, CT5 3SE United Kingdom Tel: +44(0) 1227 505 022	
		<b>SWL 1000lb</b> DOT - PUBLIC USE LIFT 455kg UNIFORMLY DISTRIBUTED	
MODEL: iCLASS™ Lift LIFT SERIAL NUMBER		<input type="text"/>	
mobilitynetworksgroup.com			

**Figure 1.2.1 Identification Plate**

Installer
Installation Date
Serial Number



**WARNING**

# DO NOT REMOVE OR TAMPER WITH THE IDENTIFICATION PLATE, THIS WILL VOID WARRANTY

## 1.3 Using the Manual

This manual aims to provide users and operators with all the information they require to ensure that they are able both to use the lift appropriately and are able to manage it as autonomously and safely as possible.

Before performing any operations on the lift, users and operators must carefully read the instructions given in this publication.



The iCLASS wheelchair lift conforms with the safety requirements of FMVSS 403; Platform lift systems for motor vehicles. All the necessary instructions for the correct installation of the wheelchair lift are detailed for the installer in compliance with FMVSS 404; Platform lift installations in motor vehicles. Together with a list of maintenance instructions for servicing procedures.



**WARNING** All installation and service procedures should be carried out in accordance with current health and safety laws.

### The Approved Service Engineer must:

- Ensure the vehicle stability is not affected by the lift, either stowed or fully deployed and fully loaded.
- Carry out the installation in accordance to the indications detailed within this manual.
- Carry out the installation by following the indications of the vehicle manufacturer.
- Complete the Warranty registration card.
- Carry out the verification check procedure for the first commissioning by following the instructions detailed in this manual.
- Register the verification check procedure for the first commissioning in the “use and maintenance” manual.
- Pass the required documentation to the final customer, in compliance to rules and regulations in force. Send another copy to the Mobility Networks to register the warranty.
- Carry out the inspections in compliance with the instructions detailed in this manual.
- Register the inspections in the Fitting and Service manual.

## 1.4 Documentation

The end user should receive with the iCLASS wheelchair lift:

The installation and weight test certification completed and signed by the installer.

Fitting and Service Manual completed by the installer.

**Mobility Networks is at your complete disposal for further clarification and instructions.**

## 1.5 IMPORTANT Wheelchair Integrated Occupant Seatbelts

Wheelchairs that are suitable for use as a seat in transport will comply with ANSI/RESNA WC-4 Section 19 and may be fitted with crashworthy integrated lap belts for use during transport. Compliant wheelchairs will bear the symbol shown in Figure 1.5.1.



Figure 1.6.1

It is recommended that when fitted, a crashworthy integrated lap belt is correctly fitted, positioned low on the passenger's pelvis and buckled-up before using the passenger lift.

Operators must be fully trained in the use of wheelchair tiedowns and occupant restraint systems (WTORS) that are compliant with ANSI/RESNA WC-4 Section 18 or ISO 10542-1.

Operators should also be familiar with the use of other equipment used to assist people with different types of disability and the various types of wheelchair that may be encountered.

The wheelchair user or their family or care provider are responsible for ensuring that the wheelchair has the correct equipment installed and maintained, as recommended by the wheelchair manufacturer and equipment supplier.



## 1.6 Lift Owner and Lift Operator



### **WARNING**

The lift owner is the person who purchases the product, uses or oversees the use of the lift, this person is legally responsible for the lift's safe use. They are responsible for distributing and ensuring that a copy of this manual is read and fully understood by all potential lift operators before operating the lift.

The operator is individually responsible for the safe use and maintenance of the lift. They are also responsible for the lift users and their own personal safety and in the event of an accident they will be prosecuted to the full extent of the law if they are deemed negligent. No operator will use the lift if they believe it is unsafe and doing so could injure themselves or others, they **MUST** report their concerns directly to their manager or Mobility Networks.

Legal action will also be taken if any unauthorized modifications are made to the lift without direct prior written authority by Mobility Networks.

The operator must be fully trained in all the operation aspects of the lift such as the transportation of people with motor deficiencies or disabilities. The operator must exhibit the following characteristics/ attributes for them to safely operate the lift:

**PHYSICAL** Possess the required physical qualities/ characteristics sufficiently to ensure safe operation of lift in a safe and controlled manner. Examples include:

- Good hearing & sight
- Physically capable of performing all operational functions of lift
- Not impaired by the consumption of legal and/or illegal substances (such as alcohol and / or drugs)

**MENTAL** Possess the required mental qualities / characteristics sufficiently to ensure safe operation of lift in a safe and controlled manner. Examples include:

- Understanding & application of the safety rules and procedures while operating the lift.
- Be constantly aware and pro-active to ensure the safety of operator, consumer and nearby people.
- Have the knowledge / skills to perform as an assistant and/ or operator in all aspects of lift operation, e.g. the safe transportation, loading and unloading of disabled and other passengers.

**EMOTIONAL** Possess the required emotional qualities / characteristics sufficiently to ensure safe operation of lift in a safe and controlled manner. Examples include:

- Work in a calm & safe manner while under stress so to prevent stress from impairing good judgement.
- To be emotionally stable during normal or abnormal situations

**TRAINING** Possess the required training qualities sufficiently to ensure safe operation of lift in a safe and controlled manner. Examples include:

- Completed operational training supervised by an experienced operator in Mobility Networks lifts in an environment which is safe and controlled. Such supervised training should allow the trainee to gain working experience in all operation aspects of the lift.

## 1.7 Connectivity

Lift functionality can be achieved wirelessly.

The lift can be controlled / programmed using the **Mobility Networks – Smart Lift App**.

(Download using the QR Code on front of manual / on the lift).

To pair:

On your mobile device, open the application and follow the instructions on the screen.

For both iOS / Android the app will ask for Bluetooth and Location settings to be turned on – otherwise the app cannot be used and it will close. (⚙️)

Connectivity works in the 3m (10') zone shown in Figure 1.7.1

**When operating the lift, ensure you are within reach of the power switch at all times and that you are able to view all corners of the platform.**

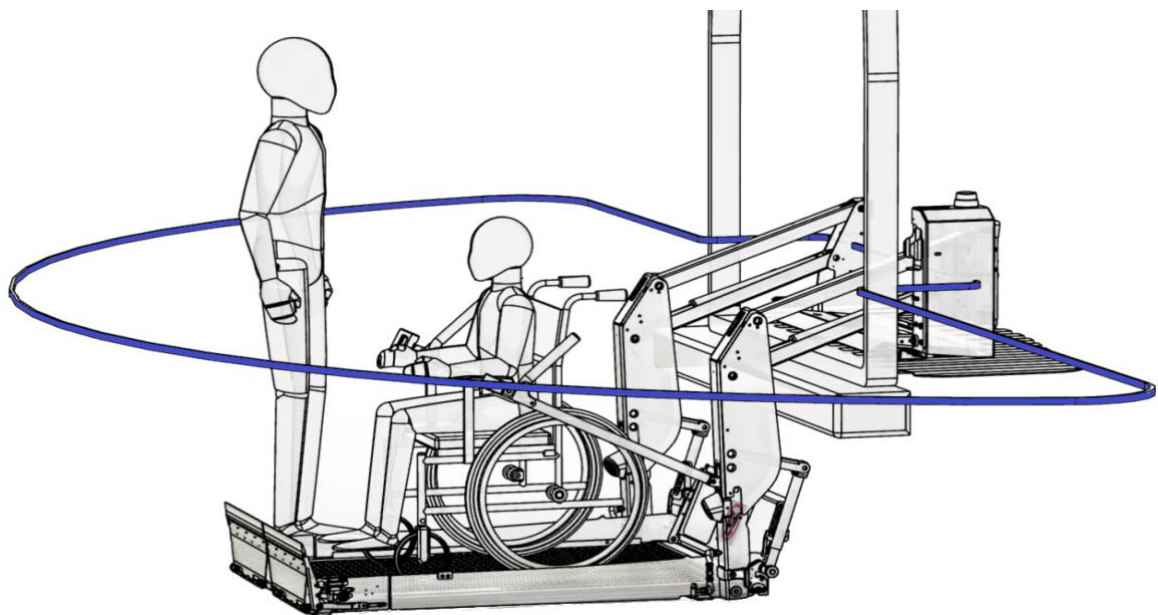

Figure 1.7.1 Wireless Connectivity Zone



### WARNING

**BEFORE OPERATING THE LIFT WITH THE APP:**

Make sure the lift and App are paired.

The PIN can be found on the Power Pack LCD Screen



Mobility Networks refuses all responsibility for damages caused by:

- Improper use of the hydraulic lift.
- Platform overloading.
- A failure in carrying out “use and maintenance” manual instructions.
- A failure in carrying out maintenance operation as detailed in the “use and maintenance” manual.
- Interventions or modifications to the lift without Mobility Networks authorization.
- When operating the lift, ensure you are within reach of the power switch at all times and that you are able to view all corners of the platform.



### WARNING

**Non-fulfilment of the manufacturer’s specified regular inspection dates may affect or even void the product warranty.**

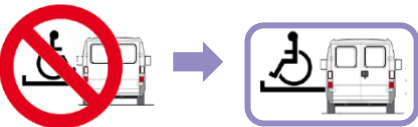
<p>Stand clear of lift when in operation and keep bystanders away</p>	
<p>Park on level ground with plenty of manoeuvring space around the vehicle</p>	
<p>The disabled person must always face away from the vehicle the vehicle. Do not approach the vehicle threshold with your back to it. Make sure the platform is in position before leaving the vehicle</p>	
<p>Do not remain stood on the inner barrier / threshold plate when lowering or stowing the lift.</p>	

Do not push against it during use.	
---------------------------------------	--

## 2.1 Genuine Spare Parts



### **WARNING**

**USE ONLY GENUINE PARTS  
USE OF NON-GENUINE PARTS AND HARDWARE MAY AFFECT OR EVEN VOID THE PRODUCT  
WARRANTY**

## 3.1 Technical Description

The iCLASS wheelchair lift (Figure 3.1.1) is installed on the deck of vehicles used for transporting persons with reduced mobility (PRM) in wheelchairs, allowing them to get into and out of the vehicle.

The lift consists of a base fixed to the vehicle loading deck, a pair of outer lifting arms installed on the sides of the base, and a loading platform, hinged between these.

Deploying/stowing and lifting/lowering movements of the lift are made by means of a parallelogram leverage mechanism driven by a pair of hydraulic cylinders (one for each outer arm). The machine is equipped with a hydraulic control unit and an electronic control box – the Power Pack (Figure 3.1.2) - which by means of a remote control performs the various functional movements. The entire system is electrically powered by the batteries of the vehicle to which it is installed.

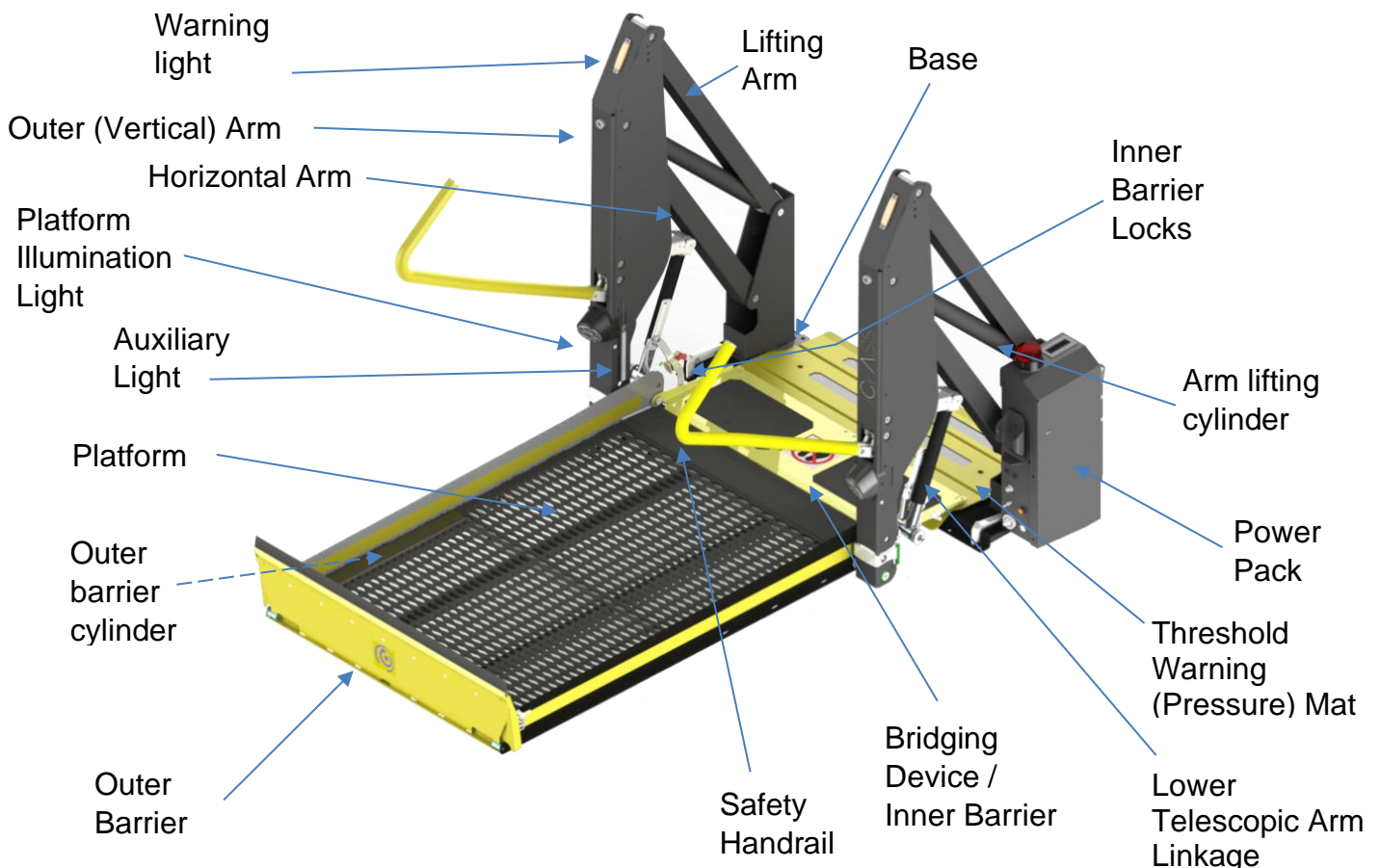
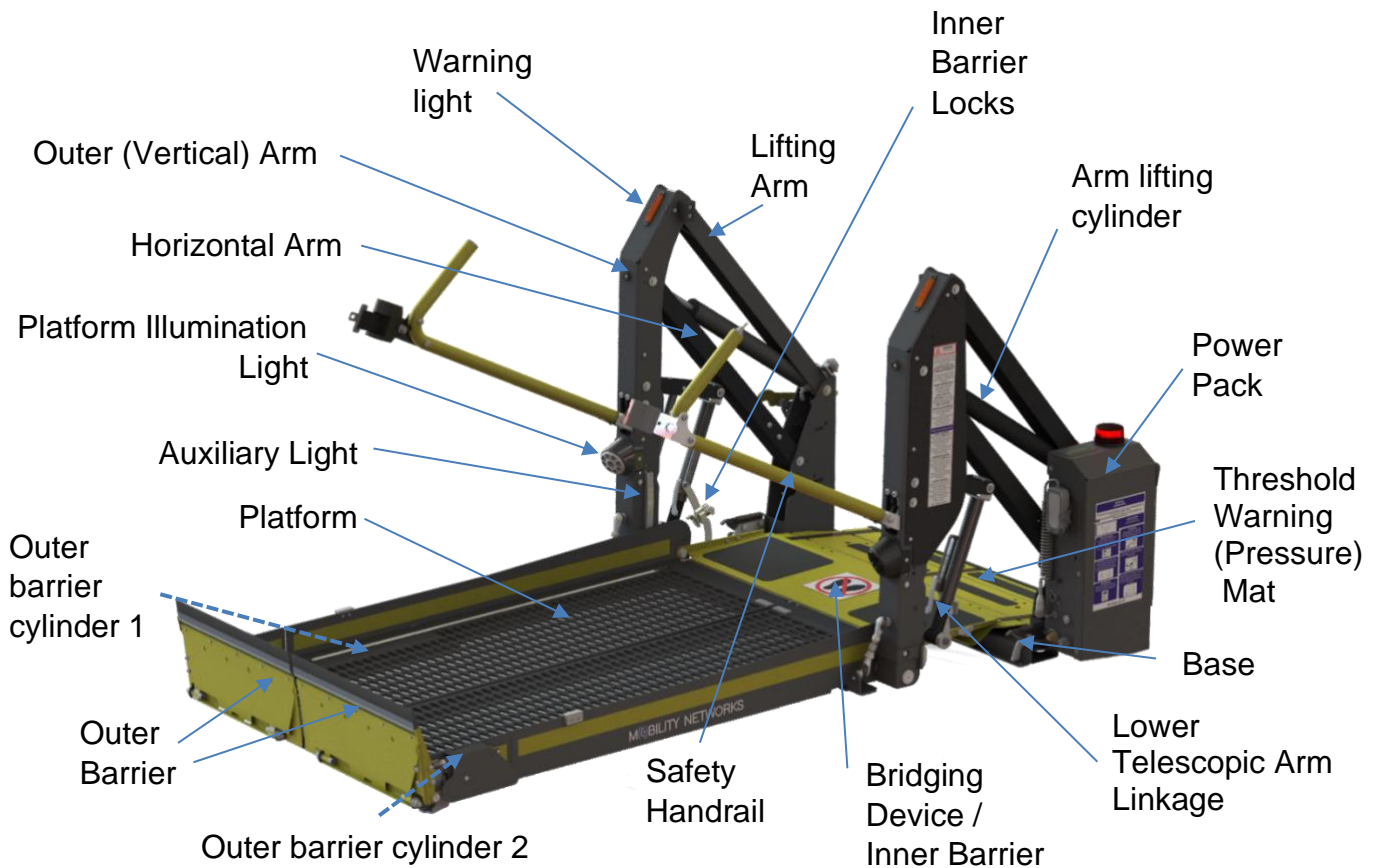
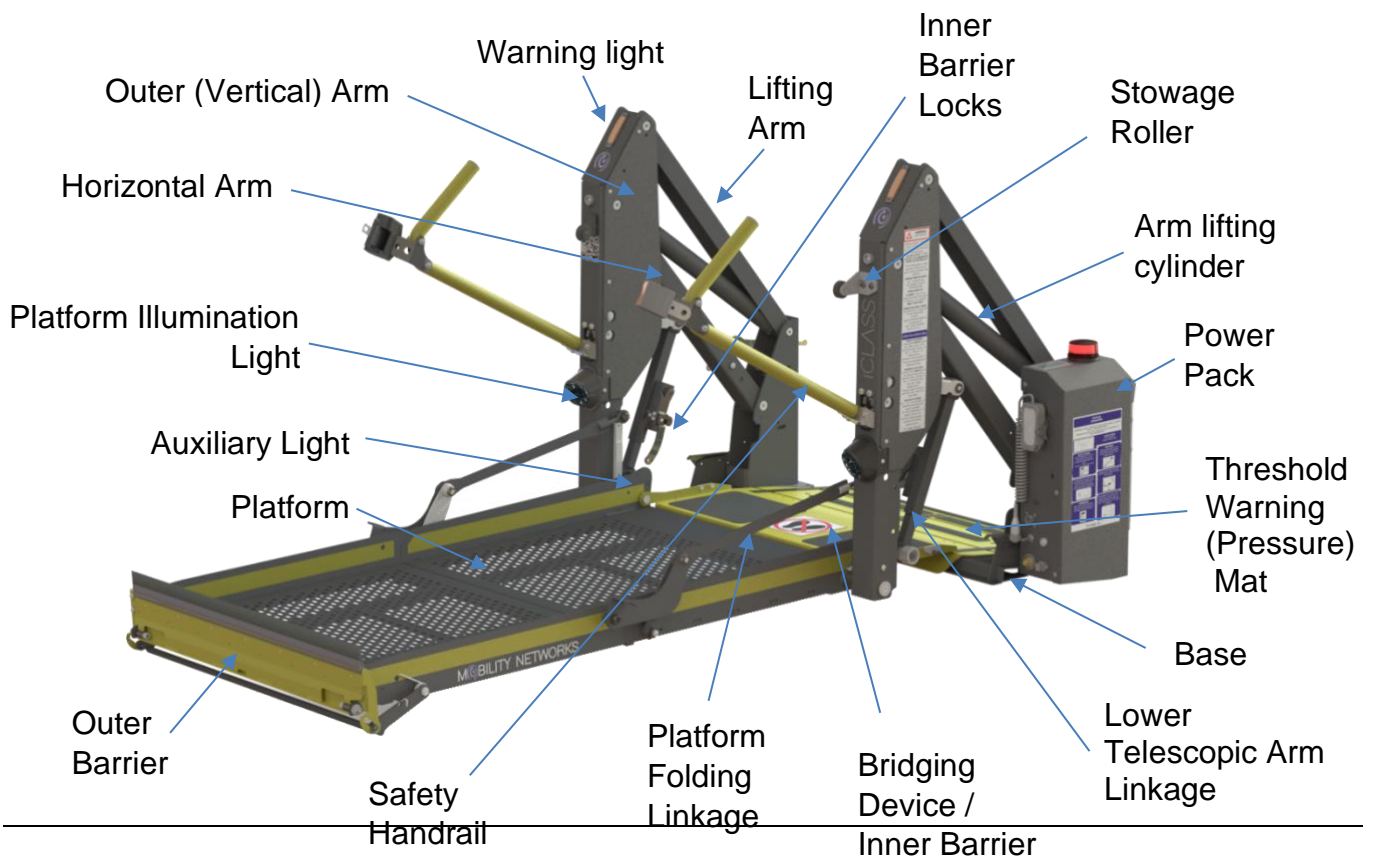

Figure 3.1.1 The iCLASS S wheelchair lift



Above: Figure 3.1.2 The iCLASS SP wheelchair lift





Above: Figure 3.1.3 The iCLASS FP wheelchair lift

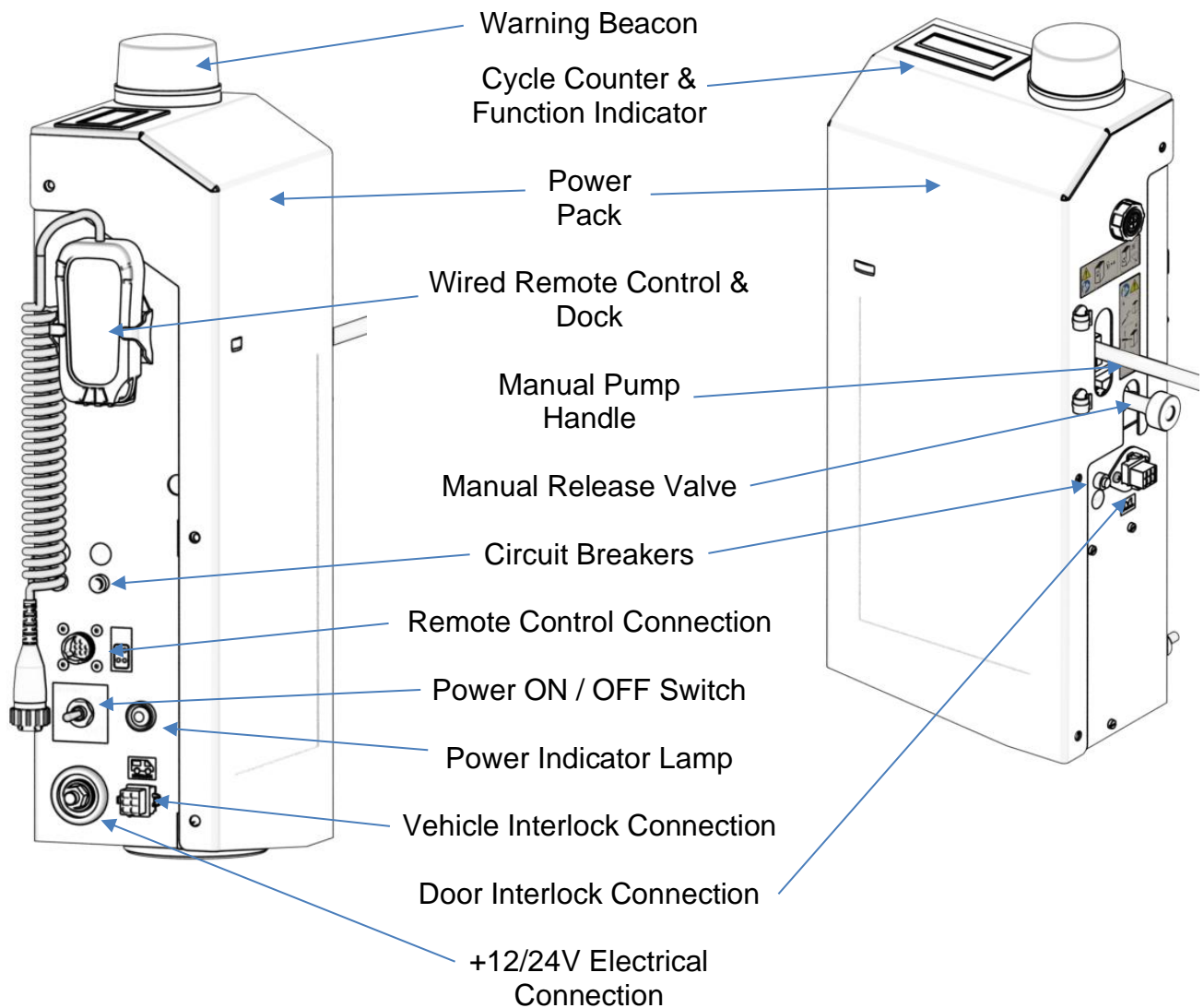

Above: Figure 3.1.2 Power Pack

### 3.2 iCLASS Model Types

The iCLASS wheelchair lift is available in three models, which differ from one another in type of loading platform:

**iCLASS S**, with a whole one-piece platform: during stowing phase platform simply rotates from loading position to vertical and back during the deployment phase. Handle Safety Belt is optional.

**iCLASS SP**, with a loading platform split longitudinally: the two parts of the platforms rotate to form a single loading platform during the deployment phase and they are separated automatically when stowing creating a space that can be used as an emergency exit from the vehicle. Handle Safety Belt is optional.



iCLASS FP, with a folded platform deployed automatically during the opening phase and folds automatically during stowing in order to reduce the overall height of the lift at rest resulting in improved rear visibility for the driver of the vehicle. Handle Safety Belt is standard.

It is also possible to prepare the wheelchair lift with following options:

Power supply voltage: 12V or 24V, Power Pack: fitted right or left.

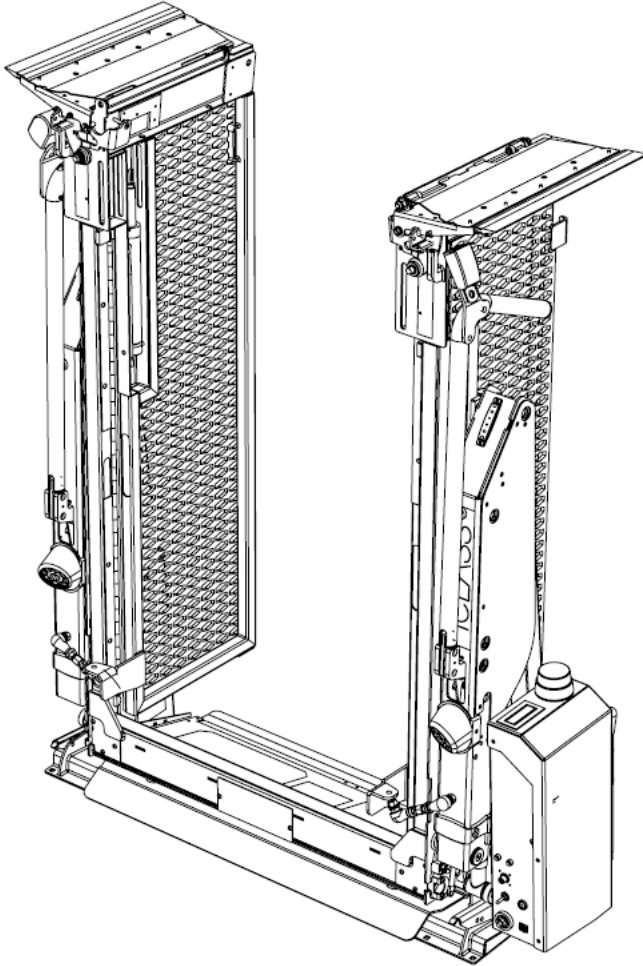

Above: Figure 3.2.1 iCLASS SP

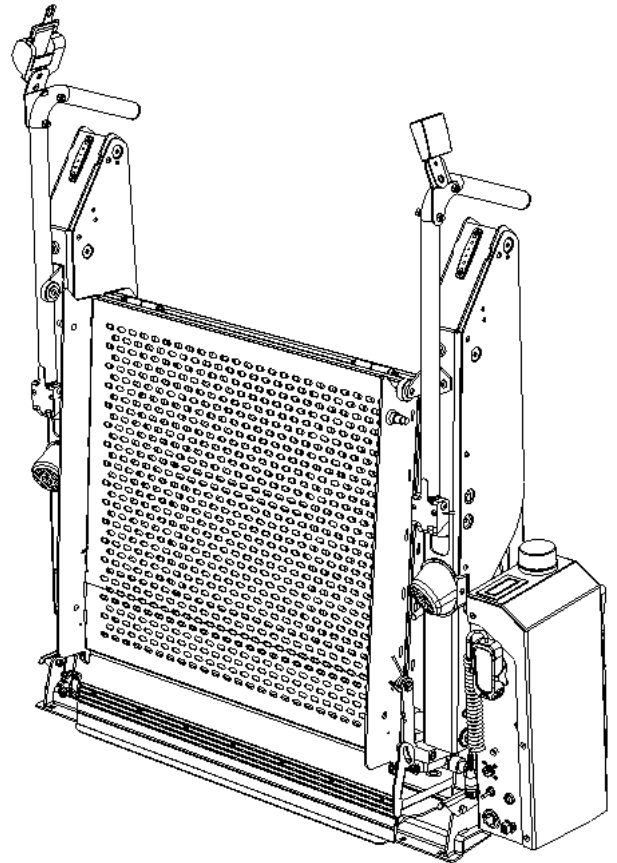

Above: Figure 3.2.2 iCLASS FP

### 3.3 Technical Specifications

Supply Voltage	12 V / 24 V (option)
Electric motor power	500W
Maximum hydraulic system pressure	130 bar (1885 psi)
Oil tank capacity	iCLASS S: 1.5 l (0.4 Gal (US)) iCLASS SP and FP: 1.0 l (0.26 Gal (US))
Safe Working Limit (uniformly distributed)	455kg (1000lb)
Maximum height reached (dependent on model)	0.79 - 1.22 m (31 - 48")
Total mass of the lift (dependent on options fitted)	125 - 160 kg

	(275 - 352lb)
Manual auxiliary hand pump	Included in Power Pack
Hydraulic oil (relevant to local environment)	15w – 32w (ATF type not recommended)
Sound Pressure (Normal)	<70 dB
With audible warning	>90 dB
Gas Spring operating temperature	-30°C to 80°C

### 3.4 Safety Devices

The items already described in previous section of the manual already provide a good level of safety, capable of avoiding danger if followed properly.



The iCLASS lifts are also equipped with additional safety and security devices:

- **Safety handrails:**  
To ensure a 'firm hold' during the lifting / lowering phase.
- **Handrail Safety Belt:**  
For lift operation maneuvers the seatbelt helps retain the lift user on the platform.
- **Bridging Device / Inner Barrier (Inner Roll Stop):**  
Portion of the platform lift that provides a transitional surface between the platform surface and the surface of the vehicle floor within the platform threshold area.  
Designed to retain mobility aids on the platform surface during the range of passenger operation.
- **Outer Barrier:**  
Wheelchair retention device that is located on the edge of the platform, is traversed during ground level loading and unloading, and is designed to retain wheelchairs on the platform surface during the range of passenger operation.
- **Guarding:**  
Covers are present on moving parts.
- **Threshold warning Private-use lift:**  
An audible warning **or** flashing red visual warning beacon (Figure 2.1.2) will activate.
- **Threshold warning Public-use lift:**  
An audible warning **and** flashing red visual warning beacon (Figure 2.1.2) will activate.
- **Protection against overturning:**  
Stops platform lowering in case of an obstacle which could induce overturning.
- **Safety pressure switch:**  
Prevents stowing when platform is still loaded.
- **Protection against overloading:**  
Prevents overload of the nominal loading capability of the lift.
- **Protection against hydraulic system leakage:**  
Maximum speed 150mm/s, typically 75mm/s. Hoses tested to over 4x max pressure value.
- **Safety Lock:**  
Prevents the unintentional opening of the platform in case of low hydraulic system pressure when the lift is closed.
- **Inner Barrier Lock:**  
Automatically locks inner barrier in place during lowering, deployed and lifting phases.
- **External signaling:**  
In addition to the warning beacon, amber warning lights are fitted on each outer arm.

- **Lighting Requirement:**

The iCLASS lift has auxiliary platform lighting fitted on each outer arm. The vehicle should also be fitted with additional loading door illumination.

It is recommended that the iCLASS lift is used in conjunction with the Inboard Lift Doorsafe, as shown in Fig 3.4.1

*See [mobilitynetworksgroup.com](http://mobilitynetworksgroup.com) for more details.*

### 3.4.1 Doorsafe

The Inboard Lift DoorSafe has been specifically engineered to act as a fixed, strong, physical barrier, used to protect passengers when the rear doors to a vehicle are open. LED lights and clear warnings give operators peace of mind that passengers are safe at all times. LED lights are an optional extra with the Inboard Lift DoorSafe barrier. The Inboard Lift DoorSafe is an automatic barrier with a manual override option. The manual override allows the barrier to be moved up and down in case sudden access is needed.



Above: Fig 3.4.1 The Doorsafe

The Inboard Lift DoorSafe is the perfect addition to any of Mobility Networks' Inboard lifts such as the iCLASS.

### 3.4.2 mobility RDO REAR DOOR OPENER

The mobilityRDO is an electrically operated rear door opener, which is often used in combination with the iCLASS Inboard wheelchair lift. The system is designed to be a “plug and play” system making it easy to mount, connect and use, thus saving man-hours.

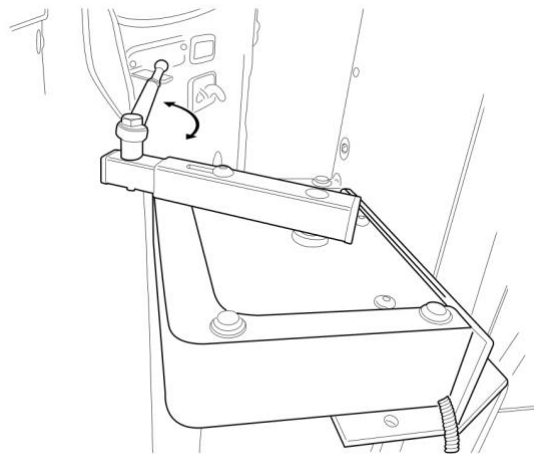

Above: Figure 3.4.2 The RDO REAR DOOR OPENER

### 3.5 iCLASS Accessibility

The iCLASS lift is designed To Transport:



One person in a wheelchair with or without an attendant, with a size not larger than the width/ length of platform space available, or weight over the stated SWL capacity.

Or:



Two walking passengers. The operator should not attempt to transport more than two people at a time because of increased risk of passenger discomfort. The passengers also may require extra space for mobility devices such as sticks and frames.



**WARNING**

The Operator must perform their proper hazard assessment and define the best practice for boarding and alighting the vehicle and lift.

### 3.6 Minimum Operating Volume

The following table gives the minimum unobstructed operating volume details for the various models:

Model	Width		Height		Length		Volume mm <sup>3</sup>	Volume in <sup>3</sup>
	X	X	Y	Y	Z	Z		
iCLASS P90148L	870	34.3	762	30	1400	55.1	928116000	56637
iCLASS P90148R	870	34.3	762	30	1400	55.1	928116000	56637
iCLASS P80130L	770	30.3	762	30	1200	47.2	704088000	42966
iCLASS P84138L	800	31.5	762	30	1300	51.2	792480000	48360
iCLASS P84138R	800	31.5	762	30	1300	51.2	792480000	48360
iCLASS P75110L	720	28.3	762	30	1000	39.4	548640000	33480
iCLASS SP84130L	800	31.5	762	30	1200	47.2	731520000	44640
iCLASS SP84130R	800	31.5	762	30	1200	47.2	731520000	44640
iCLASS SP90148L	870	34.3	762	30	1400	55.1	928116000	56637
iCLASS SP90148R	870	34.3	762	30	1400	55.1	928116000	56637
iCLASS SP76104L	730	28.7	762	30	1000	39.4	556260000	33945
iCLASS FP80150L	770	30.3	762	30	1400	55.1	821436000	50127
iCLASS FP80150R	770	30.3	762	30	1400	55.1	821436000	50127
iCLASS FP84138L	810	31.9	762	30	1300	51.2	802386000	48965
iCLASS FP84138R	810	31.9	762	30	1300	51.2	802386000	48965

### 4.1 Transport and movement

For transportation, the lift must be secured to a pallet and packed with sheets of protective plastic and / or cardboard. For transportation purposes, a fork lift truck or a hoist is advised. All packing materials are recyclable. The packing materials should be disposed of correctly. If necessary, contact your local waste department for advice regarding disposal requirements.

 **DANGER** Cardboard and protective plastic sheets used for packing purposes can cause suffocation. Dispose of responsibly.

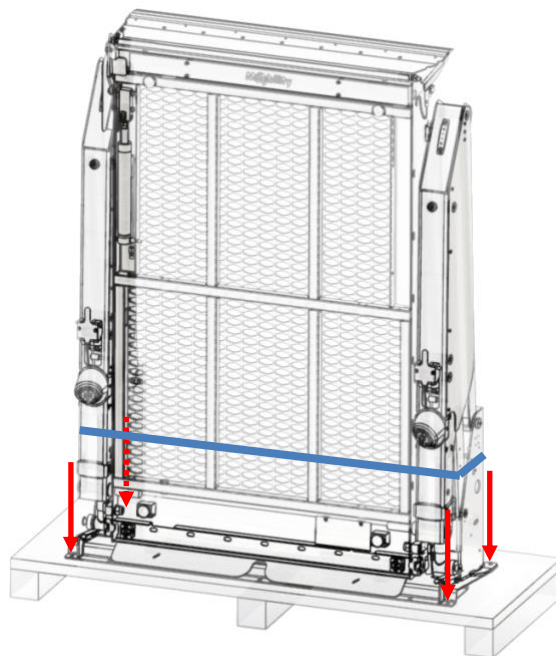

Figure 4.1 iCLASS S

Shipped on pallet showing fixing screw positions (**RED**). Use 10mm wrench to remove.  
IF BANDED (**BLUE**), do not remove until instructed.





## 4.2 Packaging

Packaging may vary depending on model ordered and shipping methods.  
Fully crated, the size of the **iCLASS** wheelchair lift package is 1370 x 520mm (54" x 21").  
The height of the wheelchair lift package varies according to the model type.  
140 cm (55") for the **iCLASS FP** model;  
1600mm (54") for the **iCLASS S** and **iCLASS SP** models.  
The crated packaging weight is approximately 38 kg (84lb).  
The boxed packaging weight is approximately 15 kg (33lb).

 **WARNING** During the unpacking process be very careful to not damage the contents.

Upon delivery of the lift perform the following inspections:

- Ensure the product delivered corresponds to the relevant documentation e.g. the order specification and the transport document.
- Examine packaging to ensure it is undamaged and all parts are intact during transportation.
- With great care, examine all devices to ensure they haven't been damaged during transportation and all parts haven't been tampered or removed.
- Ensure all documentation required for installation has been supplied. Store safely.

 **WARNING** Before beginning any installation procedure of the wheelchair lift, you should:

- Verify if there are any specifications from the vehicle manufacturers to respect.
- Remove from the vehicle any unnecessary object that could impede the installation procedure of the lift (spare wheel, accessories etc.).
- Disconnect the electrical supply from the battery.
- Disconnect any electronic control units from the vehicle as specified by the manufacturer

## 4.3 Storage

If the lift is not used straight away, proceed as follows:

Transport lift to an appropriate storage area, free from atmospheric agents / elements.

Ensure all electrical / electronic devices are insulated from external environment so to prevent humidity damaging those components.

Storage area selected **MUST** ensure maximum temperature fluctuation is between 5°C to 50°C (41-122°F) and humidity controlled.

Ensure all sliding parts (guides, cylinders ...) are adequately protected from dust, rust and water damage.

Note: If a lift is to be dry stored for more than 12 months then the condition of all cylinder seals **MUST** be checked before operation.

 **WARNING**

**STORAGE OF THE LIFT IN CONDITIONS THAT DO NOT  
COMPLY WITH THE ABOVE MAY VOID**

## THE WARRANTY FOR ANY PARTS THAT REQUIRE REPLACEMENT



## 5 Fitting and Installation

### 5.1 Dimensions

The following diagrams show indicative overall dimensions of the versions and set-ups available of the iCLASS wheelchair lift:

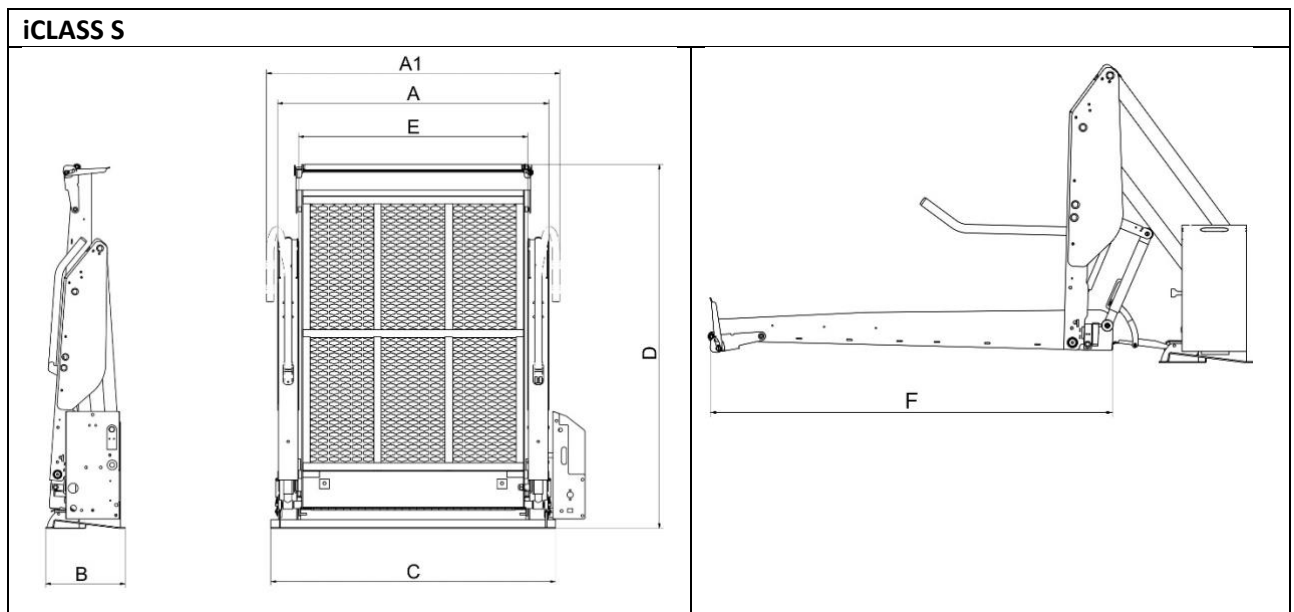

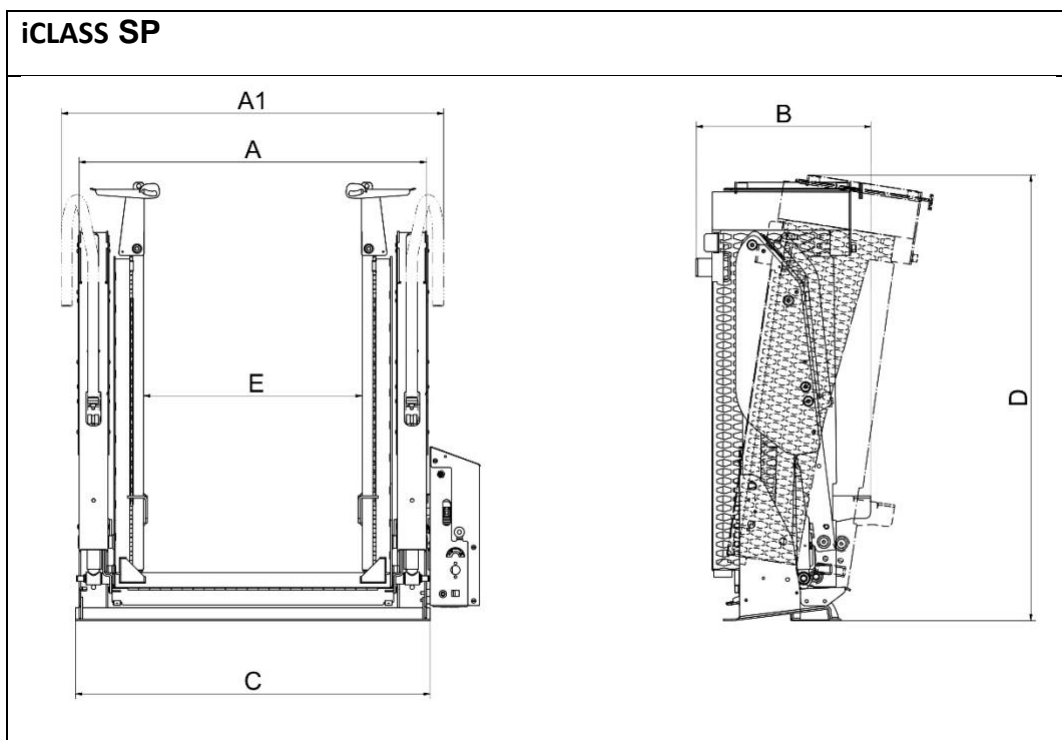
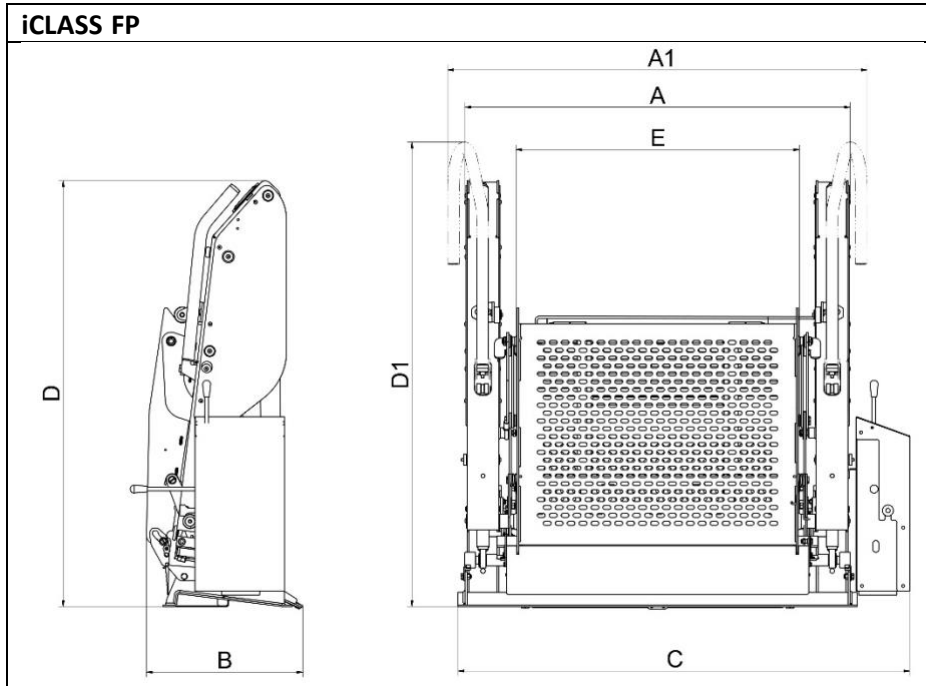

Measurements are approximate.

This table shows current variants of the iCLASS wheelchair lift, Mobility Networks reserve the right to carry out product changes and improvements in order to enhance their quality at any time and without notice. In case of doubt, please contact Mobility Networks for the latest model updates.

<i>Model Type</i>	<i>A</i>	<i>A1(**)</i>	<i>B</i>	<i>C</i>	<i>D</i>	<i>D1 (***)</i>	<i>E</i>	<i>F</i>	<i>Maximum Vehicle Floor Height</i>
** Width of FMVSS Handrails      *** Height of FMVSS Handrails									
iCLASS P90148L FMVSS	1106	1106	428	1286	1513		900	1480	1000
iCLASS P90148R FMVSS	1106	1106	428	1286	1513		900	1480	1000
iCLASS P80130L FMVSS	1006	1006	428	1187	1417		800	1300	1000
iCLASS P84138L -D-FMVSS	1046	1046	428	1226	1465		840	1380	1220
iCLASS P84138R -D-FMVSS	1046	1046	428	1226	1465		840	1380	1220
iCLASS P75110L -FMVSS	956	956	428	1127	1220		750	1100	790
iCLASS SP84130L -FMVSS	1046	1046	540	1226	1405		840	1300	1000
iCLASS SP84130R -FMVSS	1046	1046	540	1226	1405		840	1300	1000
iCLASS SP90148L -FMVSS	1106	1106	540	1286	1585		900	1480	1000
iCLASS SP90148R -FMVSS	1106	1106	540	1286	1585		900	1480	1000
iCLASS SP76104L -FMVSS	966	966	428	1146	1174		760	1040	790
iCLASS FP80150L -FMVSS	1057	1057	428	1221	1098	1216	800	1500	1000
iCLASS FP80150R -FMVSS	1057	1057	428	1221	1098	1216	800	1500	1000
iCLASS FP84138L -FMVSS	1097	1097	428	1237	1098	1216	840	1380	1000
iCLASS FP84138R -FMVSS	1097	1097	428	1237	1098	1216	840	1380	1000

## 5.2 iCLASS Lift Fitting Kit

	<b>Description</b>	<b>Quantity</b>
<b>A</b>	M10 Nyloc Nut	13
<b>B</b>	M10 Washer	13
<b>C</b>	M10 Fender Washer	2
<b>D</b>	Carriage Bolt M10x70 Grade 8.8	13
<b>E</b>	Carriage Bolt M10x100 Grade 8.8	6
<b>F</b>	Carriage Bolt M10x220 Grade 8.8	3
<b>G</b>	Square Under-Floor Plate	8
<b>H</b>	Rectangular Under-Floor Plate	2
<b>J</b>	Wired Remote Control	1
<b>K</b>	Vehicle Label	1
<b>L</b>	Vehicle Label	1
<b>M</b>	+ve connection wiring loom	1

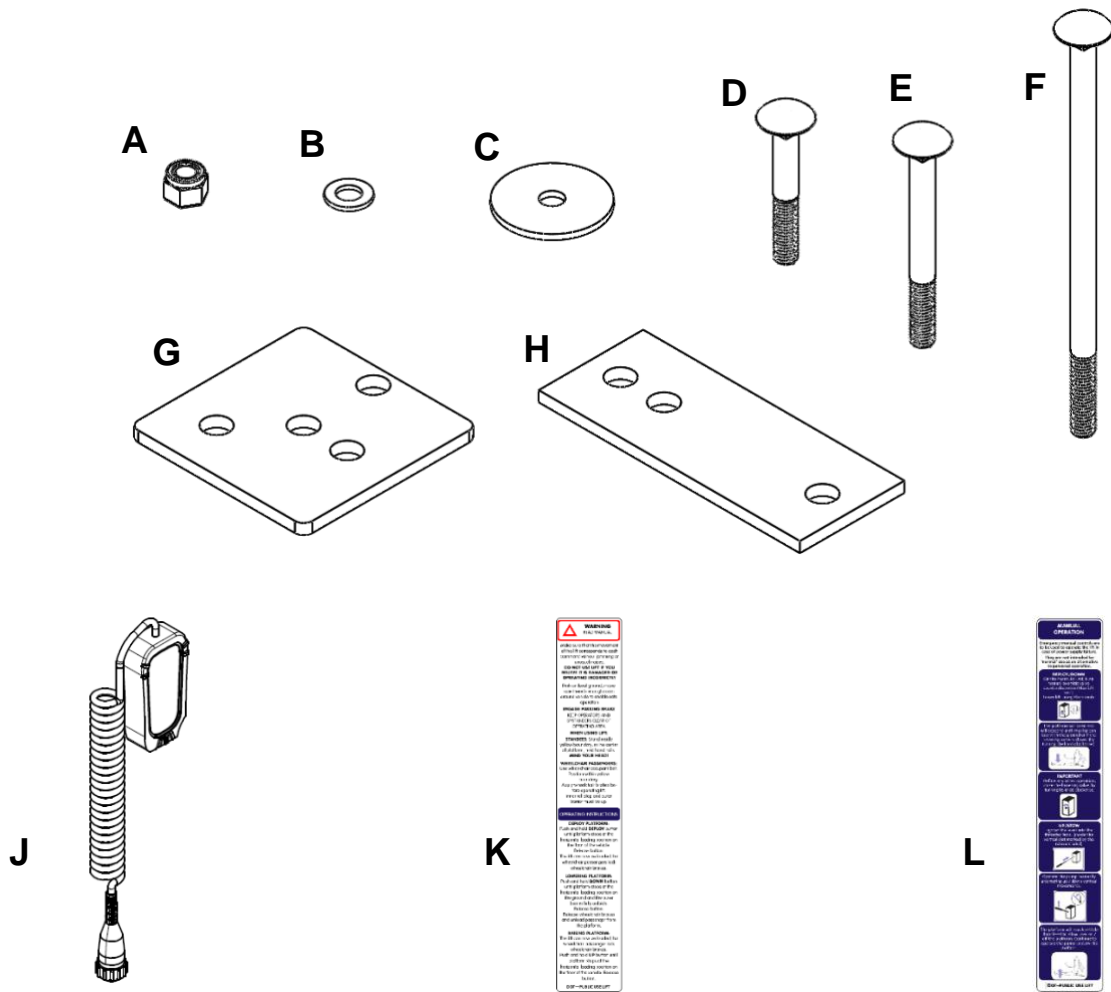

(12x carriage bolt, nut and washer are required, an extra set is included in the kit as spares)  
 +ve connection wiring harness (M) not shown.

The CAB0227 is also delivered in the kit. This connector (X9.1) is required to install the interlock by the converter.



*Exact contents may vary depending on lift model and region.*

### 5.3 Lift positioning and fixing

- **DO NOT REMOVE INNER BANDING UNTIL THE LIFT HAS BEEN POSITIONED ONTO THE FLOOR IN THE VEHICLE AND SECURED**
- Pressurize the hydraulic system of the lift by using its hand pump: screw the provided lever into its proper place in the hydraulic control unit (Figure 5.3.1) and put the hand pump into action with an alternate vertical up-down movement until the pump resistance blocks the lift in the stowed position.
- Open the door(s) of the vehicle where the lift will be placed, and block them open. Measure the height and the width of the compartment and verify that they are bigger than the overall dimensions of the lift (Figure 5.3.2).
- Using a forklift or equivalent, raise the iCLASS lift to the same height as vehicle floor. Push the lift inside the vehicle in a central position in respect to the volume of the compartment. Align the external edge at the base of the lift parallel to the closing edge of the door(s).

Verify, both inside and outside of the vehicle, that the doors of the vehicle close correctly with no interference with the lift. Measure the minimum distance between the doors and the lift; if it is more than 40 mm (1-1/2 inch) (minimum distance) (Figure 5.3.3) it is possible to move the lift toward the doors until it reaches the minimum distance. Ensure the lift is horizontally centered within the width of the compartment (Figure 5.3.2). Pay attention to the external edge at the base of the lift and the closing edge are positioned parallel (Figure 5.3.4).

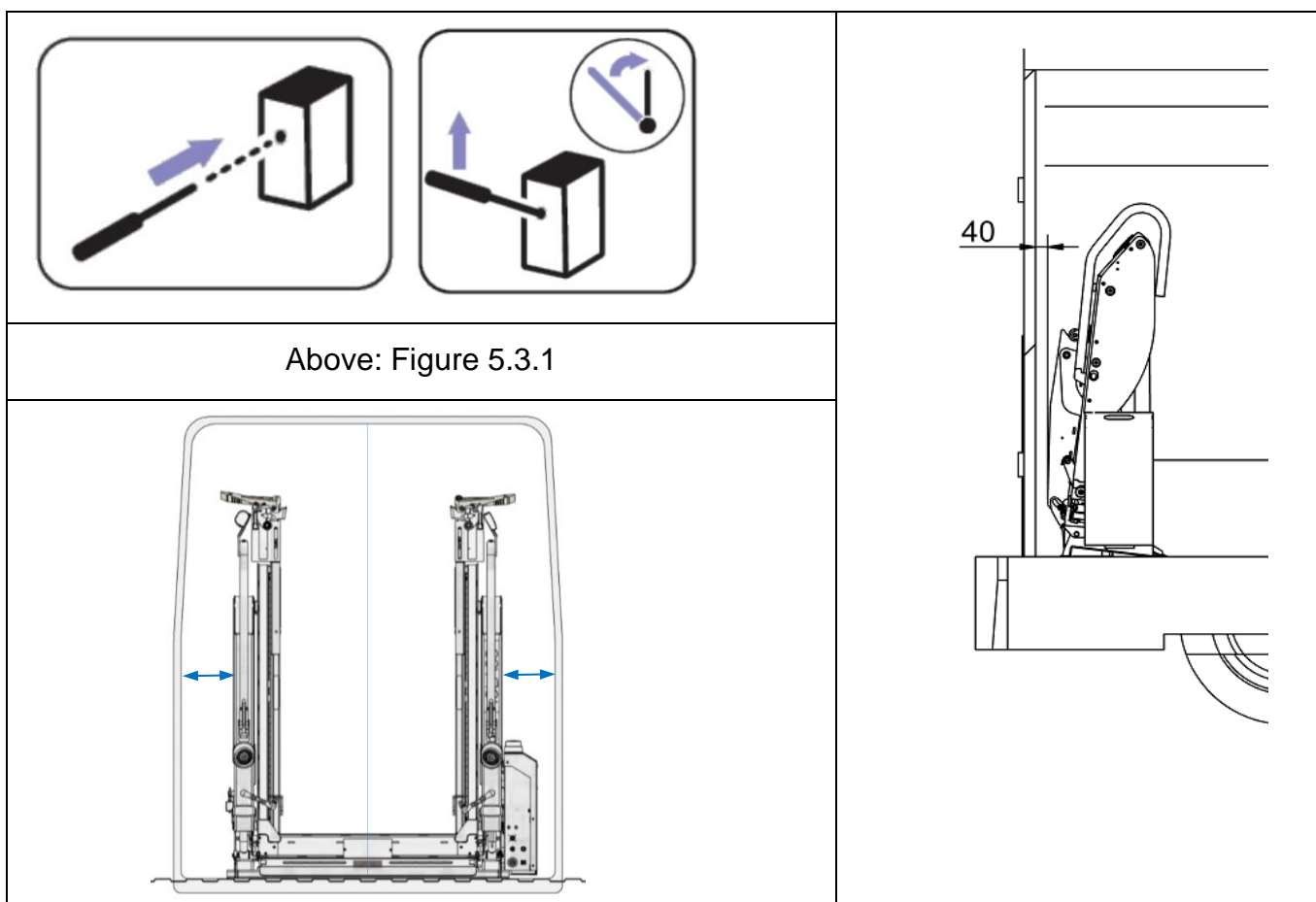

Above: Figure 5.3.2

Above: Figure 5.3.3

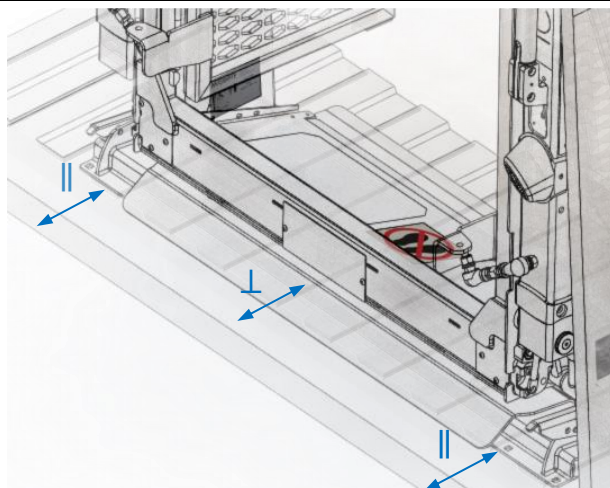

Above: Figure 5.3.4



**WARNING**

Before fixing the lift, ensure that there will be no interference of the fixing bolts with parts under the frame, such as fuel lines, hydraulic conduits or wireways, electrical wiring, cables etc. Move the lift sideways to avoid interference.

Having identified the exact position of the lift on the fitting surface area of the vehicle:

1. Trial Fit. Drill pilot holes, then 10mm to allow M10 Bolts to pass through. Initially, only drill and fix Holes 7 and 9. Fix lift using mounting bolts.
2. The shipping strapping can now be removed
3. Deploy lift to make sure there is enough bumper clearance.
4. When sure that the position is OK, use the other 10x holes at the base of the lift as a guide to drill holes. Refer to Figure 5.3.5



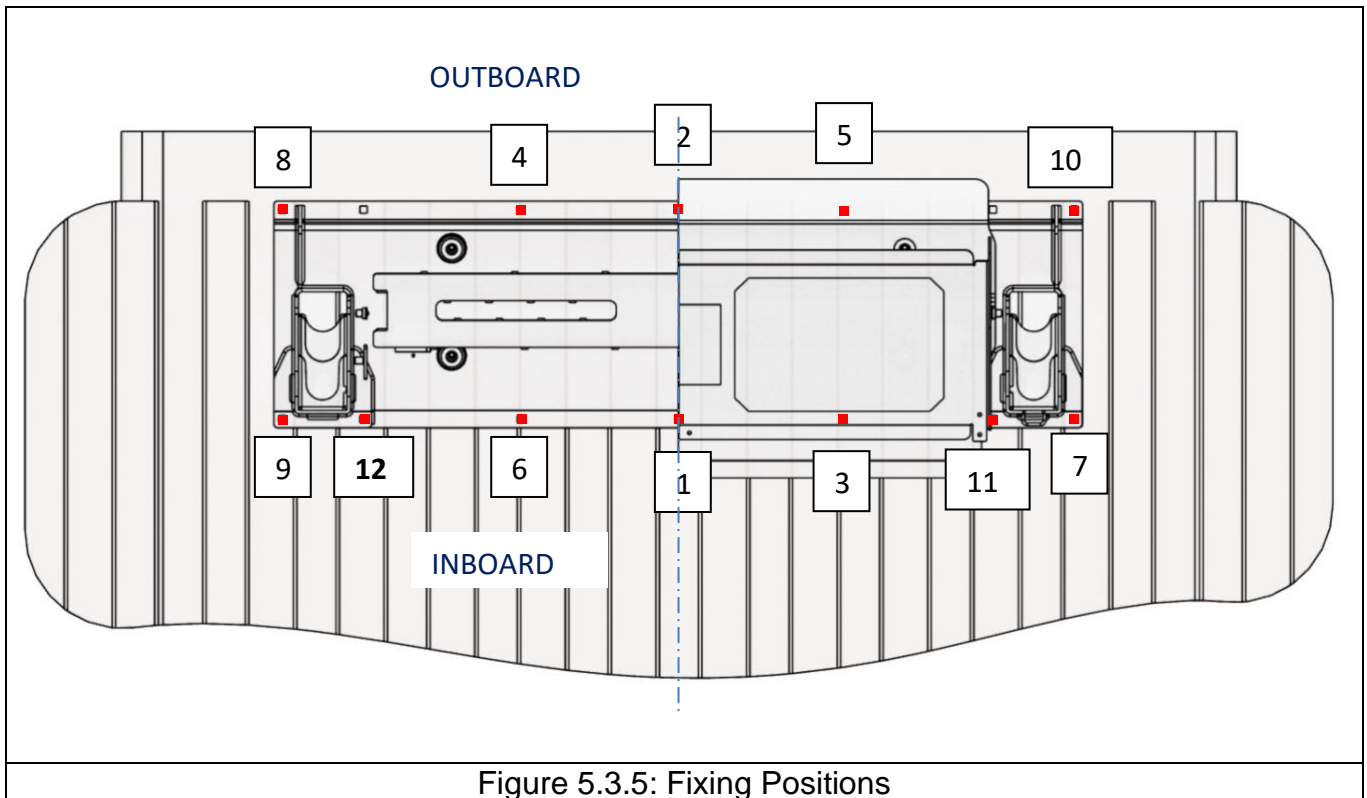

Figure 5.3.5: Fixing Positions

It is important to ensure that the supporting surface to which the lift will be fastened is stable and that the holes do not affect the stability of the lift. The lift is provided with fastening plates and these have to be positioned, in correspondence to the holes, under the frame (Fig.5.3.5 shows inboard view). They need to be tightened using quantity 2 x Rectangular Under-Floor Plates under the inboard towers (7, 9, 11, 12 using 4 x M10 carriage bolts, nuts and washers) and 8 x Square Under-Floor Plates, M10 carriage bolts, nuts and washers (Fig.5.3.6 shows outboard view). **Tighten to correct torque specification for the bolt type used (See Section 10.1). Tightening to final torque should be done in the order shown.**

**⚠ WARNING** If it is essential to use bolts with a length greater than those supplied, make sure that they are M10 class 10.9 bolts. Carriage bolts are recommended to make sure pressure switches operate correctly and to reduce the possibility of trip hazards.

**⚠ WARNING** Most vehicles have a corrugated structure (Fig.5.3.7) and in these cases the empty spaces and voids need to be filled with plates (packers) in the bolt fixing area to prevent any panel crush. Make packers from aluminum plate to make cutting to length and hole positions easier and help prevent damage from corrosion.

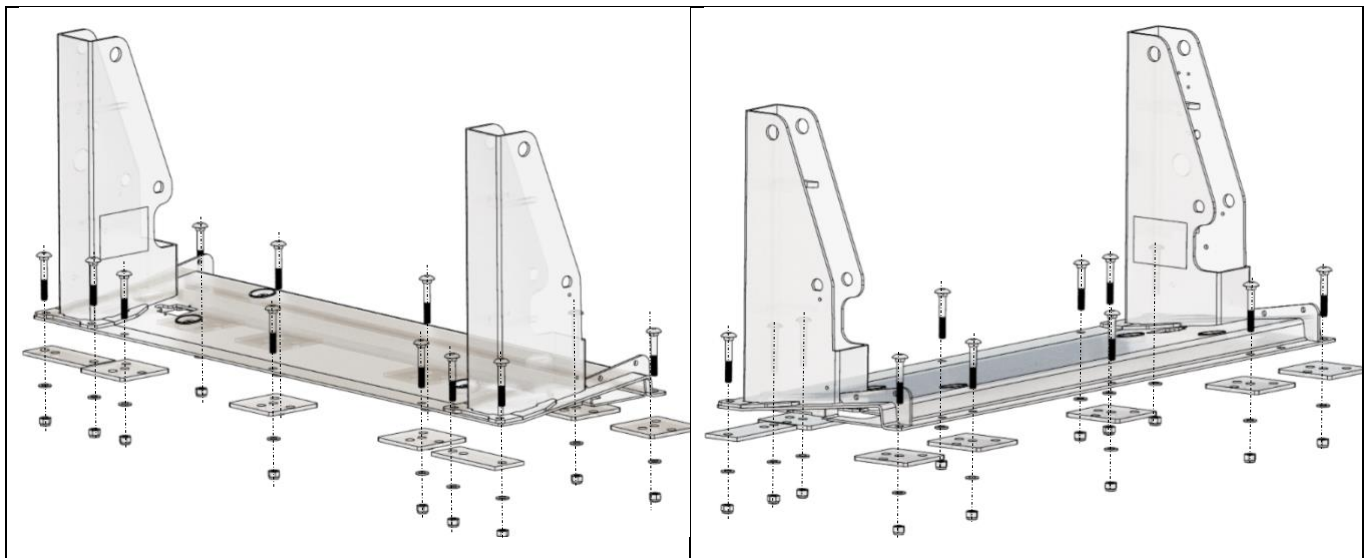
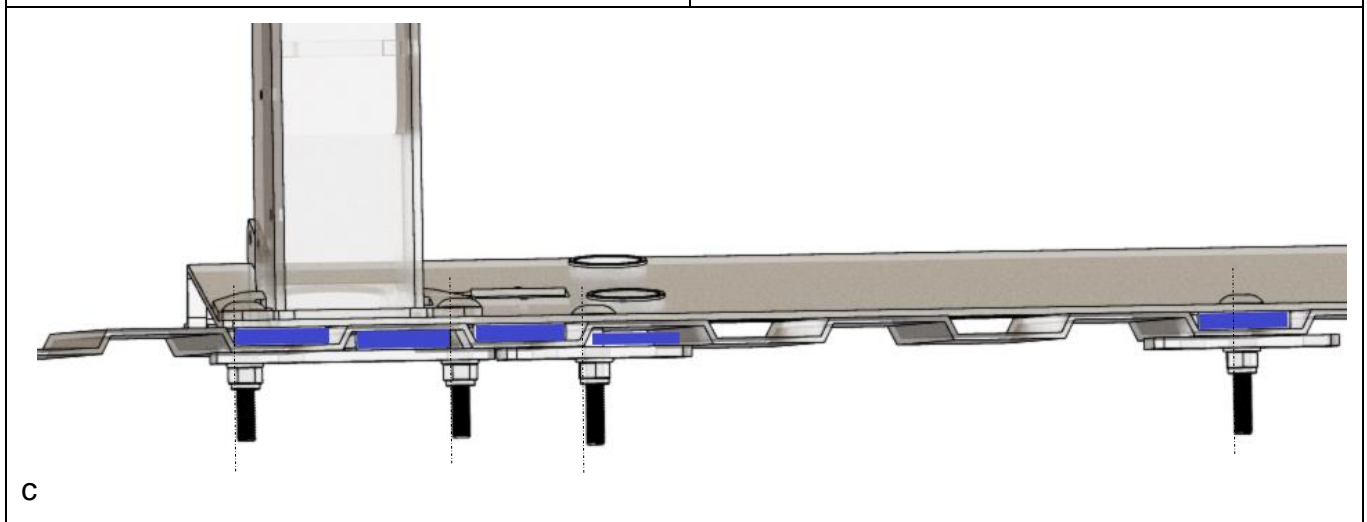

Figure 5.3.5 Inboard View

Figure 5.3.6 Outboard view



C

Figure 5.3.6 Example of how to position aluminum packers (blue) to prevent panel crush

**⚠ WARNING** - IF, in order to stiffen the area that will support the lift welding is needed, first unplug all the existing electrical connections on the vehicle and follow the manufacturer's instructions with care.

**⚠ WARNING** - It is the responsibility of the installer to verify the adequate resistance and crush proof characteristics of the surface of the vehicle to which the lift will be attached.

Mobility Networks Holdings Ltd. declines all responsibility for any damage to the vehicle or lift caused by these requirements.

Incorrect fitting to that specified voids the warranty of the lift.

## 5.4 Correcting the angle of the towers

If, after fitting, the towers are not vertical it is possible to correct this as follows:

**Figure 5.3.7** Towers angled inwards: Slacken the bolts and add packing under the base around the center fastenings, working outwards with thinner packing until the towers are perpendicular to the base. Once adjustment is completed, tighten to correct torque.

**Figure 5.3.8** Towers angled outwards: Slacken the bolts and add packing under the base around the outer fastenings, working inwards with thinner packing until the towers are perpendicular to the base. Once adjustment is completed, tighten to correct torque.

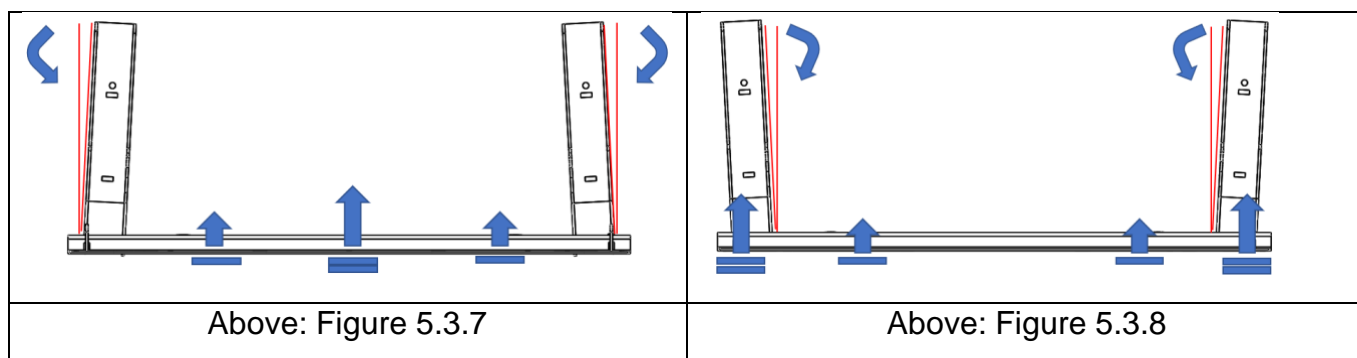

## 5.5 Fitting Safety Handrails



**WARNING:**

The Lift may be packaged and shipped **WITHOUT** Safety Handrails.

Handrail type should be selected and correctly installed **BEFORE** the first operation of the lift.

Socket Cap Hex Screws are factory fitted to the lift.

Tools Required: 3, 5, 6mm Hex (Allen) wrenches,  
13mm Combination Wrench

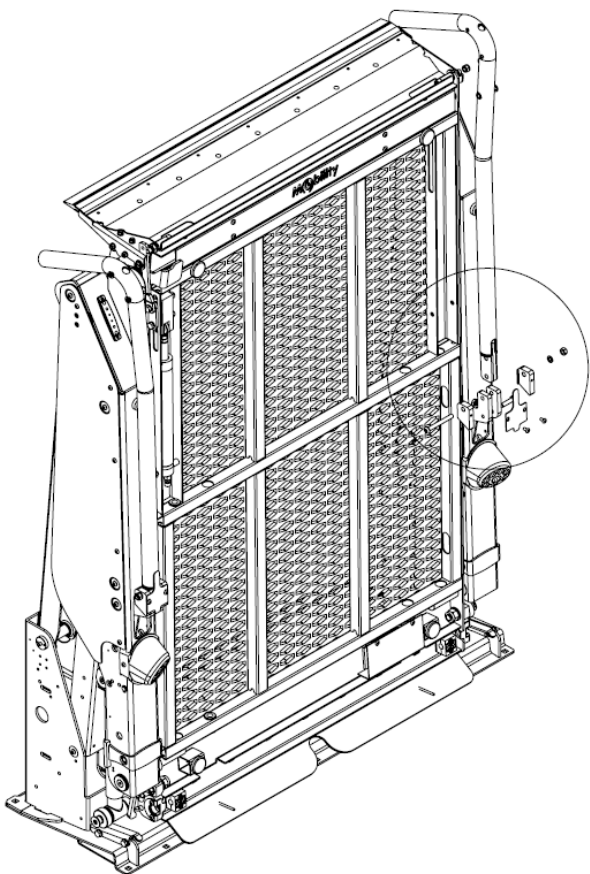

### **Disassemble handle flange:**

Remove cover plate (Quantity 2 M5 x 10mm dome hex screws) (with 3mm Hex (Allen) key (A)

Remove M8 x 70mm dome hex screw (with 5mm hex (Allen) key, nut (with 13mm combination wrench) and washer. Note position of reinforcement plates and remove. (B)

Remove M8 x 30mm (with 6mm hex (Allen) key) hex cap screw. (C)

Fit safety handrail and reverse the above to re-assemble.

Thread lock (medium strength) must be used.

**Tighten to torque specified in Section 10.1**

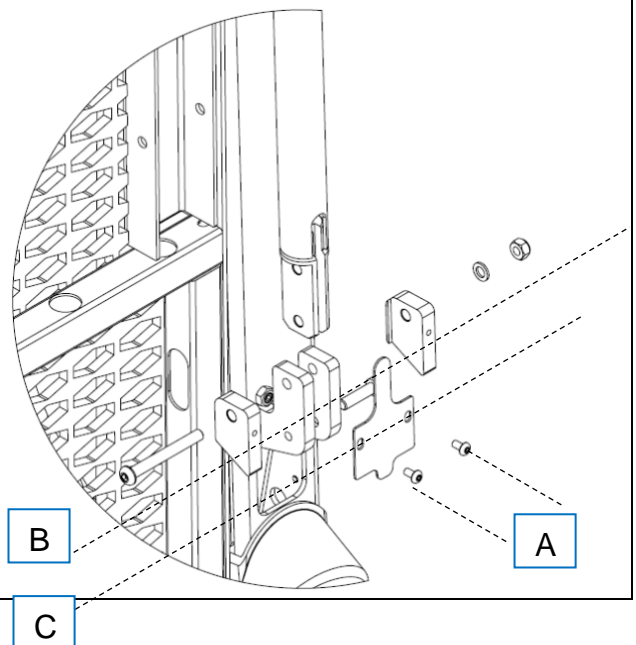

## 5.6 Fitting Handrail Safety Belt

The iCLASS FP has Handrail Safety Belts fitted as standard.

**The lift will not operate without it.**

The Handrail Safety Belt is optional but **RECOMMENDED** for the iCLASS S and SP

Description		Quantity
C1A	Safety Belt Retractor	1
C1B	Safety Belt Buckle	1
B1B2C	Fitting Plates, Left and Right	1 Set
C1D	7/16" UNF x 3/4" Screw	2
C1E	7/16" Washer	2
C1F	7/16" Nyloc Nut	2
B3G	M8 x 50mm Dome Hex Screw	4
B4H	M8 Washer	8
B5J	M8 Nyloc Nut	4
D1K	Safety Belt Wiring Harness*	1
B6L	Grommet	2

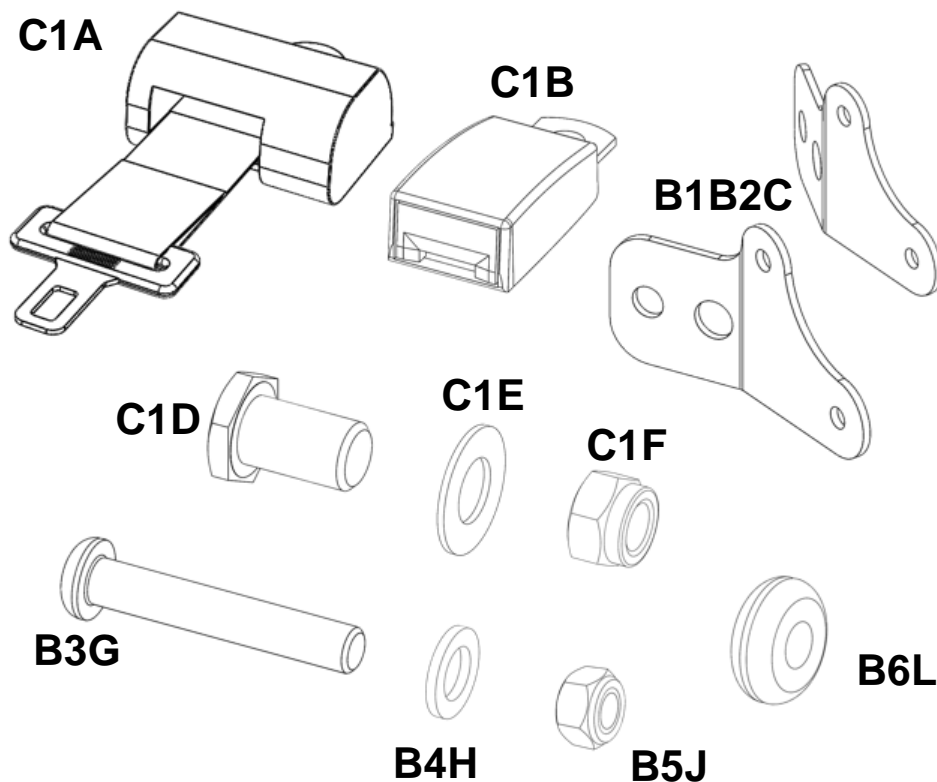

\*Wiring Harness (K) Not Shown

**See Section 12.24 for Installation Instructions.**

**See Section 9.1 and 9.3 for usage instructions.**

## 6.1 Power Supply

After correct positioning and fastening of the lift to the loading deck of the vehicle:  
Fit the battery isolation device.

On the Powerpack, toggle down the LIFT POWER switch to OFF

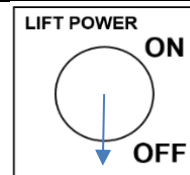

Before connecting lift, install a warning light inside the vehicle cabin and connect the female connector (not included) to its male connector positioned inside the hydraulic control unit. (use PIN4 positive and PIN6 negative). Connect DOOR OPEN to wire from PIN 6 on the ECU.



Figure 6.1.1 Power Pack NEGATIVE (-) Connection

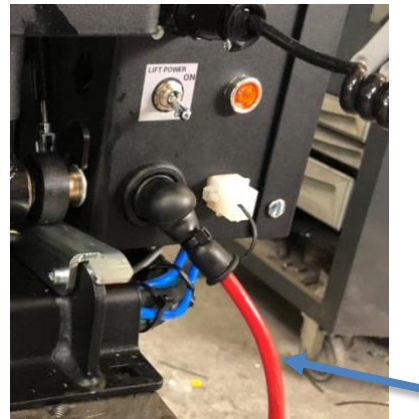

Figure 6.1.2 Power Pack POSITIVE (+) Connection

Connect the eyelet connectors of the 16 mm<sup>2</sup> wires to the vehicle battery.

RED wire to the POSITIVE (+) pole. The POSITIVE connection **MUST** have an 80A breaker (trip or MEGAFUSE, Figure 6.1.3) connected within 150mm (6") of the battery.



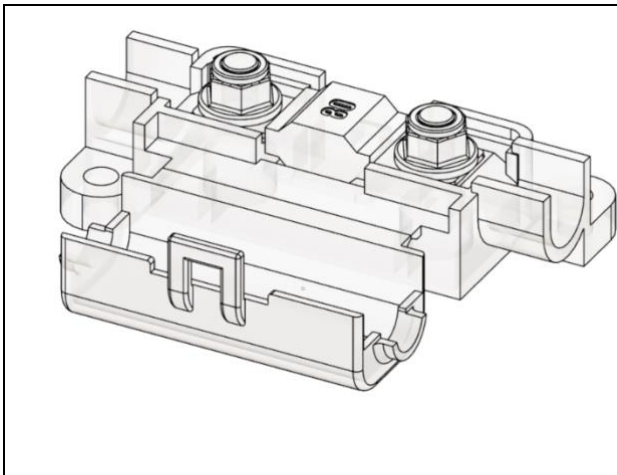

Figure 6.1.3 Megafuse - shown open

Connect the BLACK wire to the NEGATIVE (-) pole.

**△ WARNING**

Minimum wire size for main power connections is 16 mm<sup>2</sup> (5 AWG).

**DO NOT** use transformers or similar to convert AC supply to DC.

**Mobility Networks is not responsible for damage caused by incorrect power connections.**

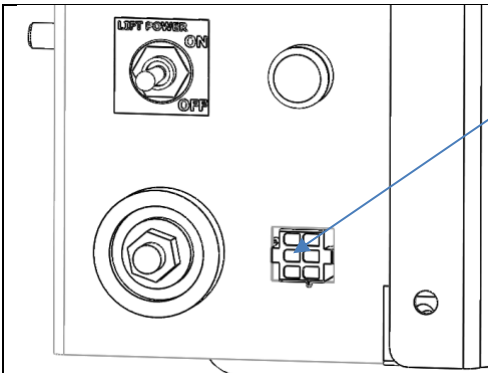

When delivered there is a link between +ve supply and pin 5 on the vehicle interlock connector. We will not supply this connector but we will supply the connector with the bridge between pin 2 and 5.

**THIS IS FOR INSTALLATION AND TEST PURPOSES ONLY**

The connector with the bridge will be used when the lift is not connected to an interlock system. it must be removed to connect an interlock system.

**PIN MUST BE DISCONNECTED BEFORE COMMISSIONING LIFT AND VEHICLE INTERLOCK FITTED**

**To connect the system interlock it is necessary to remove the original connector and use the x9.1 connector (CAB0227)**

Use 6-Pin TE type connector.

***Disclaimer: Please take time to consider the vehicle Interlock to lift system carefully. There are several 3<sup>rd</sup> party systems available however any interlock should be connected to the lift via the interlock plug ONLY. DO NOT attempt to hardwire into the powerpack directly. Incorrect wiring of the lift could adversely damage the ECU control board. Component damage may not be obvious at the time but could later affect the lifts safe and correct operation.***

**DANGER**



The lift must be **STOWED** and **FULLY ISOLATED** when the vehicle is driven



**WARNING**

Always check the LIFT POWER switch position. After the lift is used and stowed power off the lift by toggling the switch down to the 'OFF' position.

If wires need to go through walls or panels use specific rubber grommets to avoid damaging sheaths and wires.

Connecting procedures must comply with the instructions provided by the vehicle manufacturer.

Both 12V or 24V installations need a direct earth (ground) connection to the vehicle battery.

When connectors are needed use only high-quality types, IP68 or equivalents.

The connection to the vehicle battery (batteries) must pass through a vehicle electric battery isolator (Circuit breaker highly recommended or Fusible link) fitted within 150mm (6") of the battery connection.

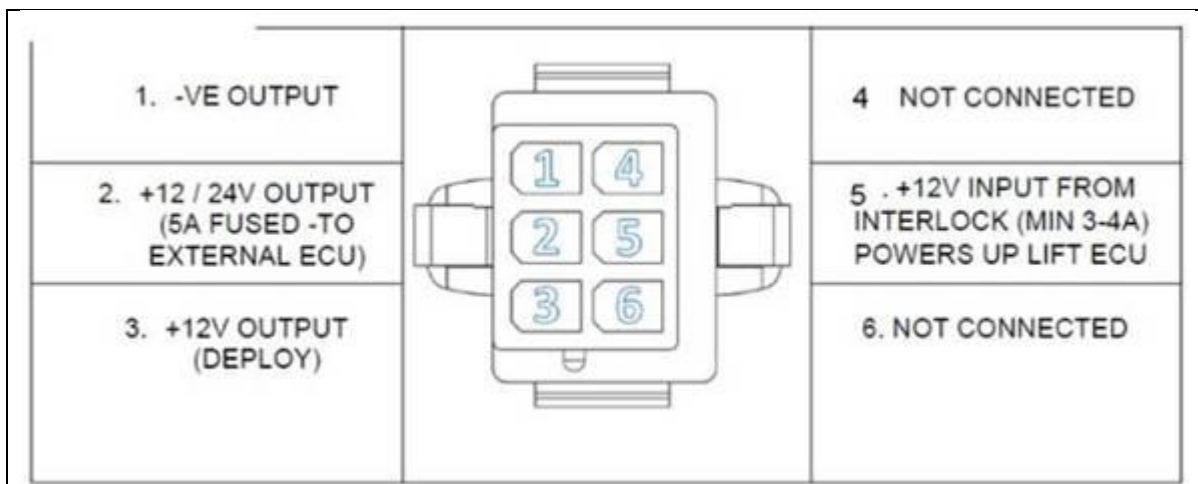

**Mobility Networks are not responsible for any damage caused by non-compliant electrical connections made within this manual AND technical specifications of the vehicle manufacturer AND other such (for example vehicle interlock) third party suppliers.**



## 6.2 Door Interlock

The door interlock socket is situated on the opposite side of the Power Pack (See Figure 6.2.1)  
Refer to the Door Opener Instruction Manual for further information.

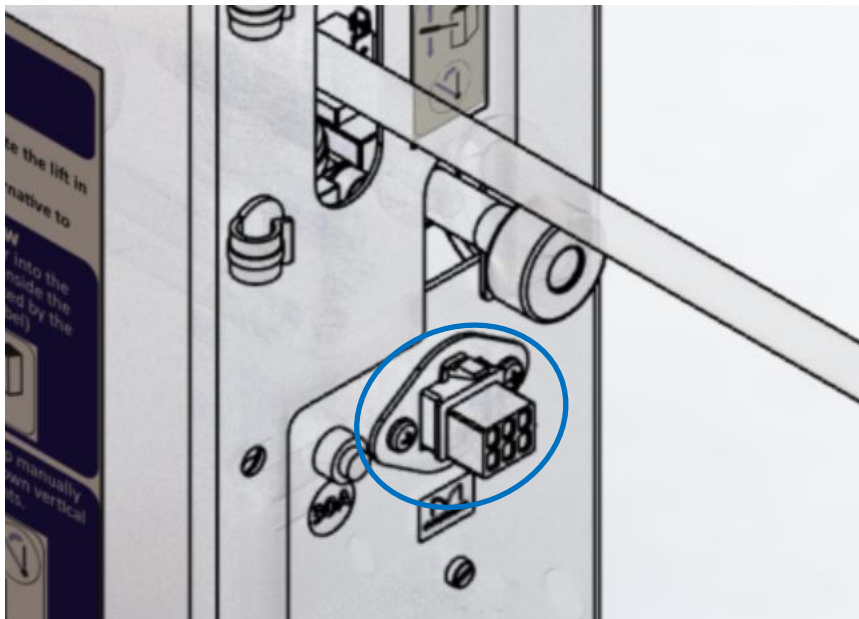
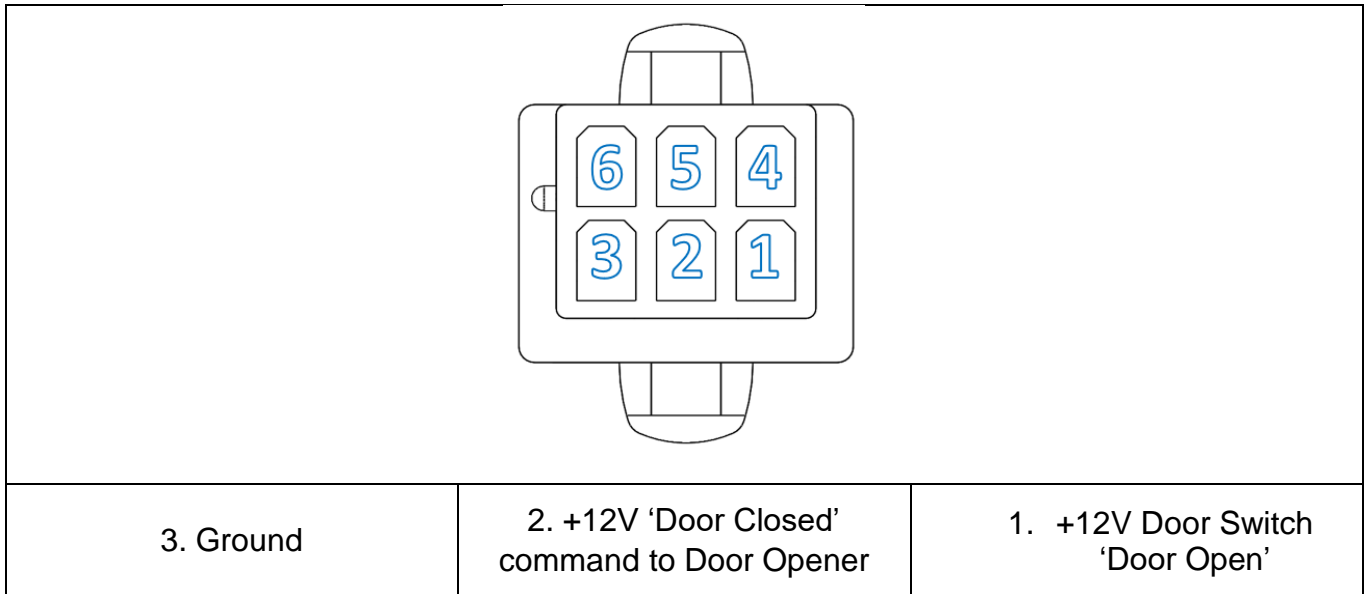

Figure 6.2.1 Door Interlock Location

The connections are as follows:

6. +12V Door Switch 'Door Closed'	5. Supply +12V 30A	1. Not Connected
-----------------------------------	--------------------	------------------



**The lift is supplied with a blanking plug which connects pin 1 to 6 when door opener for use then Door Opener is not fitted**

### 6.3 Operation Procedure and Backup Operations

This version of the manual is a major revision to that referred to in the FMVSS 403 Test Report TR-P39140-01 NC pages 5 and 6. with more detailed and improved information. Operation and Backup Operation procedure can now be found in Section 9.

## 7.1 Power Pack

The hydraulic unit is specific to the lift type and can be delivered in two versions, fitted left or right. Either version can only be installed vertically.

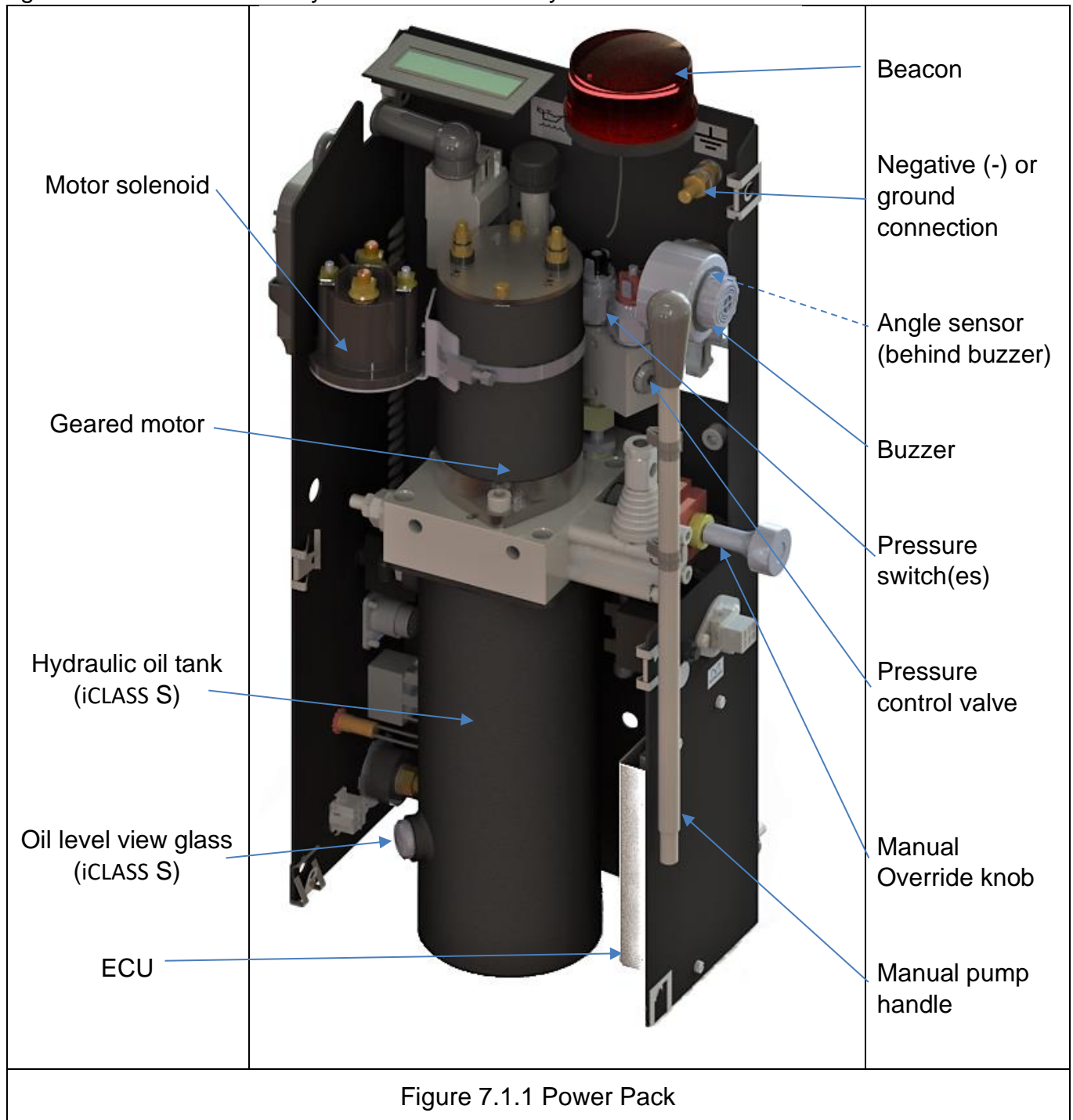
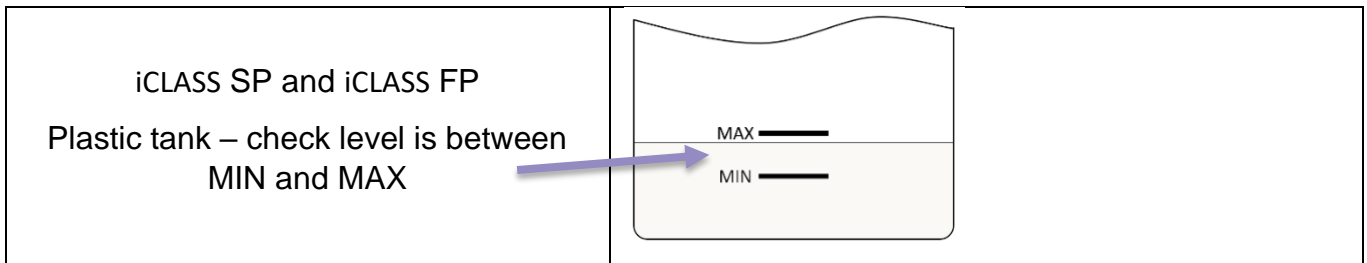
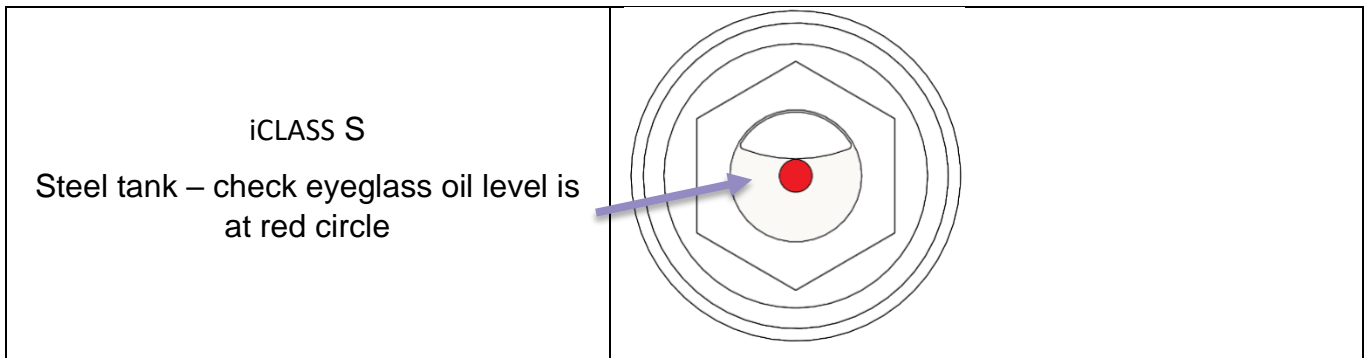

Figure 7.1.1 Power Pack

## 7.2 Hydraulic Oil level check and top-up

With the platform **FULLY** stowed regularly check that the oil level in the hydraulic oil tank is above the minimum level.



See Sections 10.6, 10.7, 10.8 for full hydraulic schematic diagrams.

**WARNING** When the vehicle engine is switched off do not to operate the hydraulic unit for more than one minute to prevent excess drain of batteries.

**WARNING** When checking and filling/topping up oil, LIFT **MUST BE FULLY STOWED**.

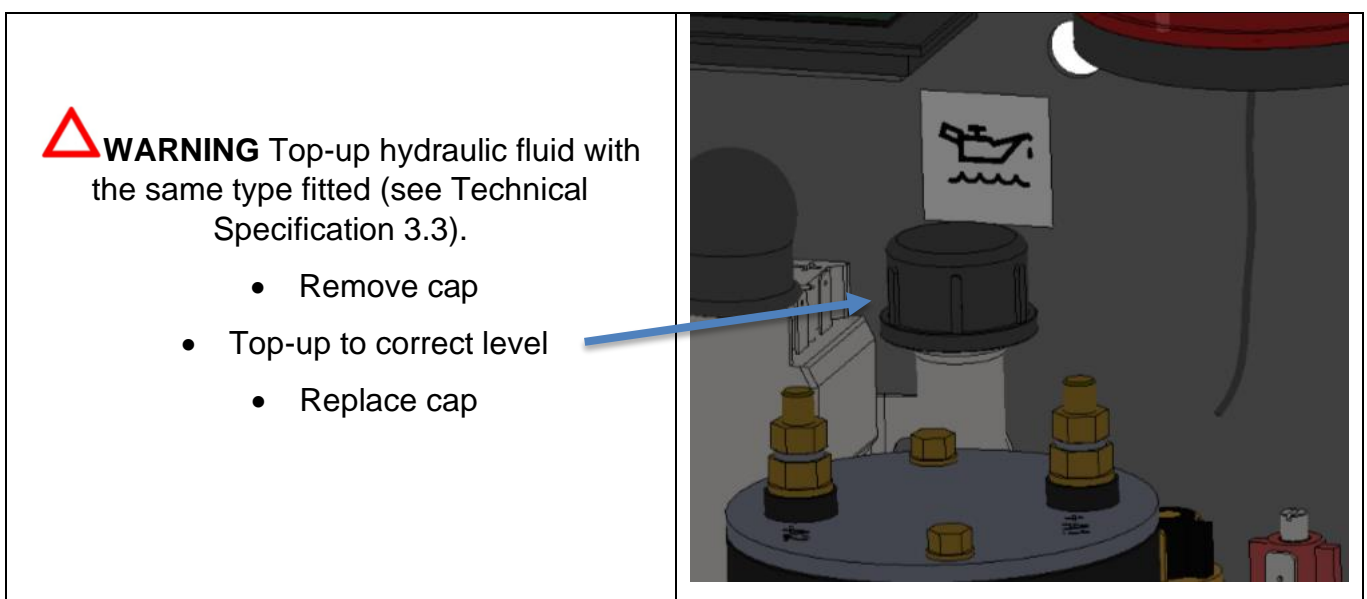

## 7.3 Hydraulic Pressure Control

### **WARNING**

These instructions are for the exclusive use of appropriately trained technical personnel. Serious personal injury and damage to vehicle could be caused if these instructions are not adhered to.

### **DANGER**

Inside the hydraulic control unit there is a pressure socket. A pressure check can be made by connecting a pressure gauge (manometer) to the pressure socket, see Figure 7.3.1.

### **WARNING**

After disconnecting from the pressure socket replace the fitting cover or cap. Mobility Networks decline all responsibility for damage caused by non-fulfillment of these instructions and automatically deem the warranty to be void in such cases.

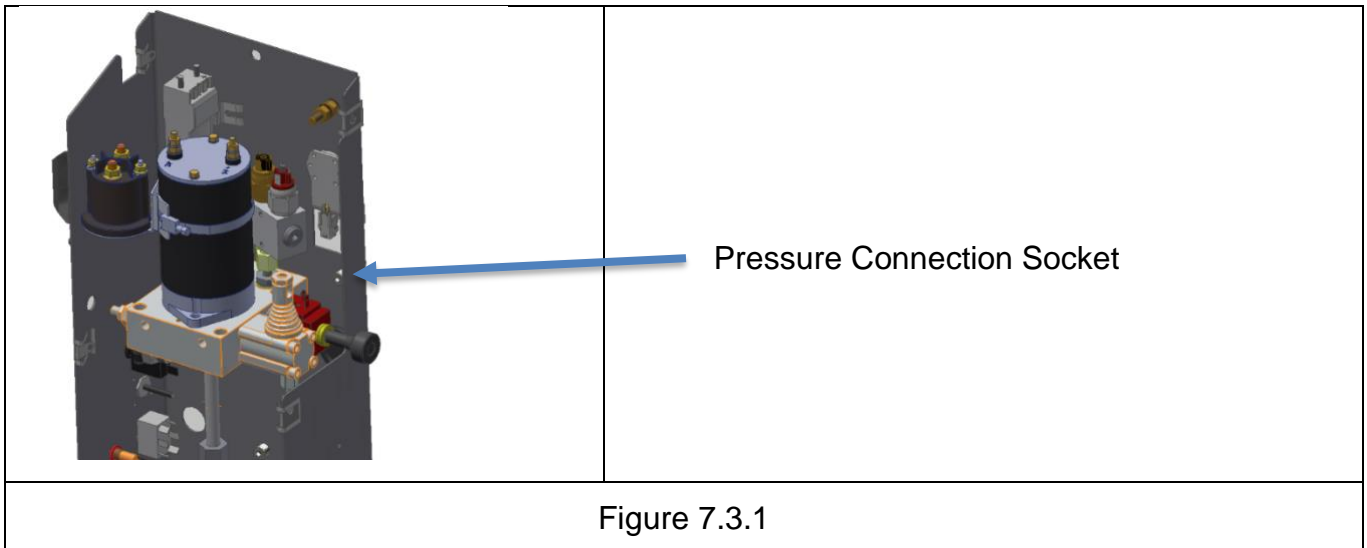

## 7.4 Pressure Control Switches

Pressure control switches differ between models (Double Switch for iCLASS S and iCLASS SP)



Figure 7.4.1 iCLASS S and iCLASS SP

Figure 7.4.2 iCLASS FP

### 7.5 Pressure Control Switch Adjustment

	<b>DANGER</b>	These instructions are for the exclusive use of appropriately trained technical personnel. Serious personal injury and damage to vehicle could be caused if these instructions are not fulfilled.	
If necessary, the Outer Barrier and Platform Stow actuators can be adjusted as follows:			
Pressure Control Switch: Outer Barrier			Pressure Control Switch: Platform Stow
iCLASS S and iCLASS SP		iCLASS S, iCLASS SP and iCLASS FP	
Turn Clockwise (CW) to increase pressure sensitivity to outer barrier		Turn Clockwise (CW) to decrease pressure sensitivity when moving platform to stowage position	
Turn Counter-clockwise (CCW) to decrease pressure sensitivity to outer barrier		Turn Counter-clockwise (CCW) to increase pressure sensitivity when moving platform to stowage position	
If triggered, the display will show:		If triggered, the display will show:	

**See Section 10 for ECU Messages, see Section 12 for adjustment procedures**



These instructions are for the exclusive use of appropriately trained technical personnel.



The following verification checks are required for completion of the commissioning of the iCLASS wheelchair lift.

Ensure the instructions in this manual have been fully understood. If further information is required, please contact Mobility Networks immediately. Serious personal injury and damage to vehicle could be caused if these instructions are not adhered to.

Mobility Networks declines all responsibility if:

- the verification check for the first commissioning is not followed properly
- the appropriate records are not compiled correctly

as this will void the warranty.

### **Pre-Operation:**

- Ensure that there are no missing or damaged parts of the machine and there is no structural failure.
- Check that all pins are correctly housed in their seats, and that they are their respective locking stops aren't missing.
- Check the integrity of the spiral cable of the control pendent and the electrical connectors.
- Check the fasteners for all the pins of the lifting arms.
- Ensure that there are no loose bolts.
- Check for clashing between cables and hoses by performing five cycles and listening for unusual noises, whilst maintaining a safe distance from the lift
- Ensure you perform the platform inclination adjustments. Adjusting the inclination of the platform is a fundamental operation for the correct operation of the lift. See section 12.20 for details.





**IMPORTANT: Perform the following during commissioning and at 6-Monthly (or 5000 cycle) Check:**



- **Threshold Mat Adjustment, Outer Barrier Check, Stow Check, Inner Barrier Check**

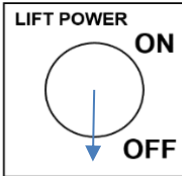
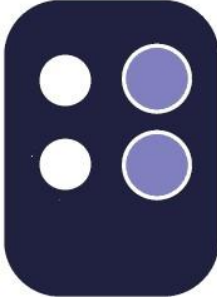
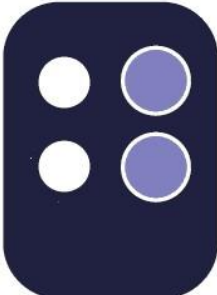

**8.1 Lift Position Setting**

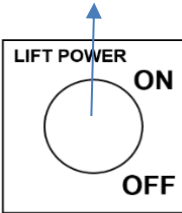

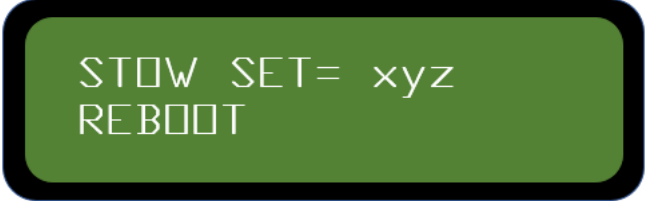
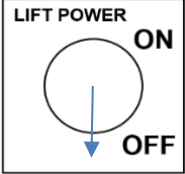
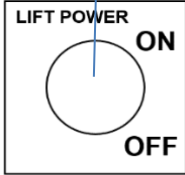
In order to set the Stowed position or the Floor Level proceed as follows:

**Ensure Power Pack is ON, then:**

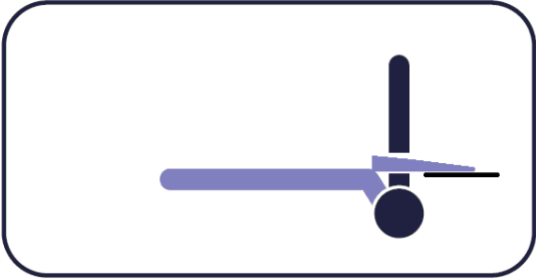
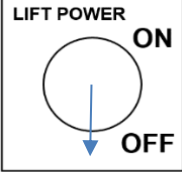
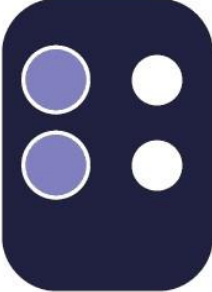
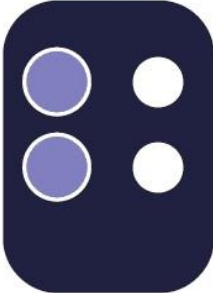
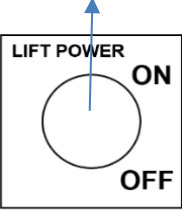
<b>To set the STOW position:</b>				
1	Move the lift to fully closed position			
2	Switch power to OFF			
3	Press and hold STOW & DEPLOY			
4	With the two buttons pressed, switch power to ON			

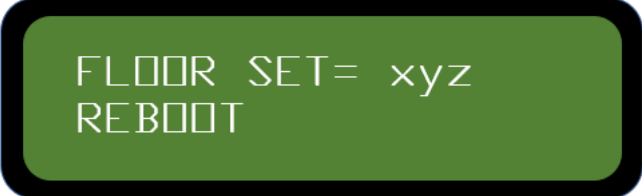
5	Check the display	
6 Release the buttons		
7	Check the display	
8	Switch OFF	
9	Switch power to ON	
10	Check the display	
11 Stow Position Programming Complete		

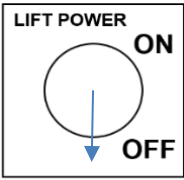
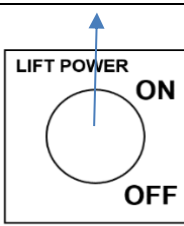
To set the Floor Level:		
1	Move lift to floor level	
2	Switch power to OFF	
3	Press and hold UP & DOWN	
4	With the two buttons pressed switch power to ON	 + 
5	Check the display	
6 Release the buttons		
7	Check the display	

8. Switch OFF	
9. Switch power to ON	
10. Check the display	
11. Floor Level Programming Complete	

## 8.2 iCLASS Weight Test Certificate

**Once fitted, the lift installation MUST be certified and the results recorded on the following pages. Send a copy of these to the manufacturer either by copy and mail or photo / email. The lift warranty may be void without this.**

.....Copy and cut out, send the copy to Manufacturer....✂.....

### iCLASS Weight Test Certificate

<b>Installer:</b>	<b>Serial Number:</b>	<b>Date:</b>
-------------------	-----------------------	--------------

#### Perform the Static deformation test:

Position the platform at 'all out' position with lifting arms horizontal.

Measure the height of the platform and its angular alignment in relation to the loading area of the vehicle.

**APPLY** a load of SWL x 1.25 onto the platform and then remove it. **REPEAT** the test.

Static Deformation Test 1: Apply a load of SWL x 1.25 onto the platform and then remove it.

Static Deformation Test 2: Repeat the height and angular measurements of the platform.

Static Deformation Test 1	Height =	Angle =
Static Deformation Test 2	Height =	Angle =

Check there are no permanent deformations either to the lift or the vehicle fixings which could be a detriment to the correct functioning of the lift

<b>Are permanent deformations visible?</b>	<b>YES / NO</b>
<b>FAIL if YES, PASS if NO</b>	<b>FAIL / PASS</b>

#### Perform the Static Deviation Test:

Deploy the lift to vehicle floor level.

Apply a load of SWL x 1.25 onto the platform.

Static Deformation Test 1: Measure the height of the platform and its angular alignment in relation to the loading area of the vehicle.

Static Deformation Test 2: Repeat the measurements after 15 minutes.

*Weight Test Certificate continues next page*

.....Copy and cut out, send the copy to Manufacturer.....✂.....

Static Deviation Test 1	Height =	Angle =
Static Deviation Test 2	Height =	Angle =
Is the vertical deviation of the platform between the two measurements greater than 15 mm and the angular change greater than 2 degrees?	<b>YES / NO</b>	
<b>FAIL if YES, PASS if NO</b>	<b>FAIL / PASS</b>	

**Perform the Dynamic Test:**

Position the platform at ground level. Apply SWL load onto the platform.

Does the lift function correctly, with a full cycle of movements, when fully loaded?	<b>YES / NO</b>
<b>PASS if YES, FAIL if NO</b>	<b>PASS / FAIL</b>

**Perform the overload safety check:**

Position the platform at ground level. Apply a load SWL x 1.25 the platform.

Does the lift platform leave ground level?	<b>YES / NO</b>
<b>FAIL if YES, PASS if NO</b>	<b>PASS / FAIL</b>

**If any checks are negative contact the lift manufacturer**

Lift Installation and Maintenance must be performed by an approved engineer.  
Non-compliance may result in serious personal injury, damage to the vehicle and may affect or even void the product warranty.

### 8.3 Maintenance Schedule – Important Information

This version of the manual is a major revision to that referred to in the FMVSS 403 Test Report TR-P39140-01 NC pages 5 and 6. with more detailed and improved information. The Maintenance Schedule can now be found in Section 12.

## 8.4 ECU and the Mobility Networks – Smart Lift App

The lift can be controlled / programmed using the **Mobility Networks – Smart Lift App**.  
 (Download using the QR Code shown on the front of manual / on the quick-start guide or on the lift).  
 Lift functionality can be achieved using Bluetooth® in the zone shown in Figure 1.7.1

## 8.5 Installing the Mobility Networks – Smart Lift App and Pairing to the ECU

1. Switch on Bluetooth & Location services  
 For both iOS and Android, the app will ask for Bluetooth & Location services.  
 The App will automatically prompt the user to switch the services on.  
 Without these, the App will not work and will close.

Open the application and follow on-screen instructions. Enable Location Services / Settings – the App will show a popup if the Location Services / Settings are not switched on and redirect the user to the Location Settings, allow when prompted

Enable location in settings.

Enable Bluetooth – the App will show a popup if the Bluetooth services are not switched on, allow when prompted

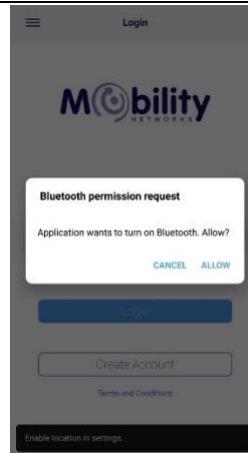

2. Press Add to search for a new ECU if no devices were registered previously to the Mobility Networks App.





3. After a device is found, press on the arrow to start the pairing procedure. The App will connect to the lift ECU.

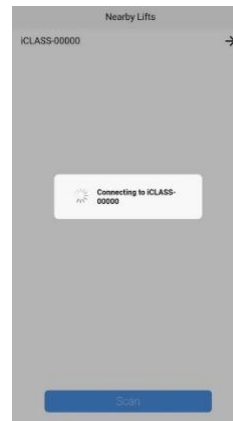
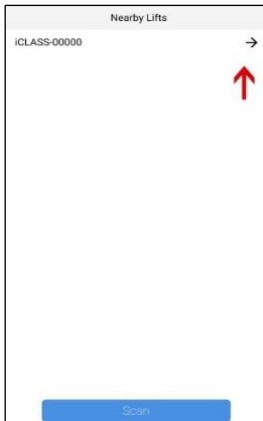

4. Entering the pin – once connected successfully to the ECU a pop-up will request the user to input a PIN. The PIN of the lift is displayed on the LCD screen every time you initiate a pairing connection using the App.

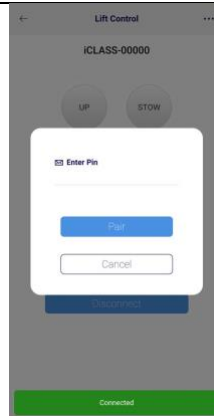

If the wrong pin is entered, the ECU will sever the connection and the pairing procedure will restart.

## 8.6 Mobility Networks – Smart Lift App DEBUG Mode and Installer ECU Tools

**DEBUG Mode** is used to help with adjusting the safety mat and ECU and Lift Diagnostics. diagnostics.

**DEBUG Mode** is set as deactivated when lift leaves the factory. If activated the DEBUG mode increases the number of logs written to the SD card and activates the siren alarm and buzzer when platform is positioned at the floor level and safety mat is pressed.

DEBUG = 1 (active) DEBUG = 0 (disabled)

**ECU logs:** When DEBUG mode is activated the ECU saves logs to the SD card of all commands sent / received by the App, all button presses of the hand control and all the states of the ECU plus various other diagnostics.

See Section 11 for further ECU information



**WARNING**

ECU logs **MUST** be interpreted by a Mobility Networks Engineer

## 8.7 Changing from 'Safety Mode' to 'Full Operation Mode'

**Safety Mode** delays or stops the operation of the lift if the lift was not taken out of safety mode or if one of the lift modules and / or sensors has started malfunctioning.

**'Full Operation Mode'** Once proper checks have been made by the engineers at the factory / by the final installer or after repairs have been made and checked, the lift can be put in 'Full Operation Mode'.

If activated, **Safety Mode** delays the Deploy operation by 10 seconds, activates the buzzer and the LCD displays '**SAFETY MODE**' every time the lift is powered on. After the initial 10 second delay, the lift will resume operation but will reset the delay every time the lift is powered off.

Safety mode will stop all operations if the temperature of the ECU exceeds 80°C (176°F), Angle Sensor is disconnected or malfunctions, or if the battery voltage is low.

All lifts leave the factory with **Safety Mode** active and it is the Installer's responsibility to put the lift in **Full Operation Mode**. Upon finishing the installation, it is recommended that the Installer pairs the lift to the **Mobility Networks – Smart Lift App** and sets the lift to **Full Operation Mode**. The date and time will also be recorded and the **Mobility Networks – Smart Lift App** will forward this info to the service provider as a record of a successful installation.

### Full Operation Mode through the Mobility Networks – Smart Lift App

Change from **Safety Mode** as follows:

1. Login to the **Mobility Networks – Smart Lift App**
2. Pair with the lift
3. In the right-hand menu, navigate to the Installer section
4. Scroll to the bottom of the page
5. Toggle the checks and press the Ready button
6. Using the App, the Engineer can only set the Safety Mode to Active /  
Installer can only set **Full Operation Mode** to Active

Alternatively, 'Safety Mode' can be set to 'Full Operation Mode' using the wired remote, see Section 11

## 8.8 ECU Details

The ECU Hardware, Software and Serial Number details can be found on a label on the ECU, an example is shown in Figure 8.7.1.

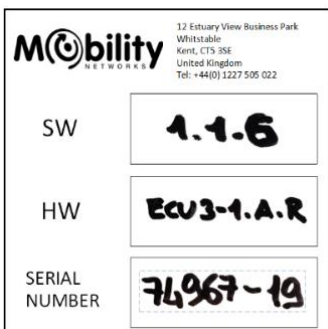

Figure 8.7.1

ECU Battery Type: CR1220

ECU Memory Card Type: Micro SD

## 8.9 Commissioning Log

The Installer shall check the following boxes to confirm and validate as follows:

### 1 IDENTIFICATION PLATE:

ID plate installed and fixings secure?	<input type="checkbox"/>
Is the ID plate serial number legible?	<input type="checkbox"/>

### 2 ENCLOSED DOCUMENTATION:

Manual for use and maintenance compiled	<input type="checkbox"/>
Manufacture's Declaration of Conformity	<input type="checkbox"/>
Installer's Declaration of Conformity	<input type="checkbox"/>
Operator Manual Supplied. Installer Information and Serial Number Recorded	<input type="checkbox"/>

### 3 LABELS AND SAFETY WARNING:

Light in the cabin operates (Section 3)	<input type="checkbox"/>
If signaling lights are fitted, do they work? (Section 3) (if not fitted note n/a)	<input type="checkbox"/>
All Labels present and legible (Section 17)	<input type="checkbox"/>

### 4 CONTROLLER:

Wired control pendent present? (if not note option fitted)	<input type="checkbox"/>
Emergency manual controls operate and label present?	<input type="checkbox"/>

### 5 STRUCTURE AND ASSEMBLY:

Confirm fastening bolts to the platform to correct torque	<input type="checkbox"/>
Visual inspection of the integrity of all welds	<input type="checkbox"/>
Absence of structural deformation	<input type="checkbox"/>
Safety Handrails fitted, thread locked and fasteners torqued to specification	<input type="checkbox"/>

### 6 HYDRAULIC SYSTEM:

Correct oil in the tank (Specification in Section 3.3)	<input type="checkbox"/>
No oil leakage	<input type="checkbox"/>
No oil in hydraulic cylinder breather holes (e.g. seal integrity)	<input type="checkbox"/>
Hoses correctly routed	<input type="checkbox"/>

7 FUNCTIONING OF THE LIFT:

Leveling of the platform at the loading floor in opening	<input type="checkbox"/>
Leveling of the platform vs. loading floor in ascent / descent	<input type="checkbox"/>
Closes Fully	<input type="checkbox"/>
Functionality of Bridging Device (Section 3)	<input type="checkbox"/>
Functionality of Outer Barrier (Section 3)	<input type="checkbox"/>

8 ELECTRICAL SYSTEM:

Isolator switch operates (Section 6)	<input type="checkbox"/>
Battery connected properly	<input type="checkbox"/>
Vehicle battery fully charged	<input type="checkbox"/>

9 SAFETY DEVICES:

Safety hook fitted and operational	<input type="checkbox"/>
Safety pressure switch fitted and set correctly	<input type="checkbox"/>

10 LOAD TESTS:

Verify static deformation	<input type="checkbox"/>
Verify static deviation test	<input type="checkbox"/>
Verify dynamic test	<input type="checkbox"/>
Verify protection against overloading	<input type="checkbox"/>

11 FULL OPERATION MODE:

Set Lift to Full Operation Mode	<input type="checkbox"/>
Check all lift functions operate correctly in Full Operation Mode	<input type="checkbox"/>

12 MOBILITY NETWORKS SMART LIFT APP

During handover the vehicle to the customer, inform them about the Mobility Networks Smart Lift App, show them how to download it to their smart phone	<input type="checkbox"/>
Before using the lift make sure the user or operator knows how to confirm connection (Pairing) to the lift using the App	<input type="checkbox"/>



**WARNING**

**BEFORE OPERATING THE LIFT WITH THE APP:**

Make sure the lift and App are paired.

The PIN can be found on the Power Pack LCD Screen

## 9.1 Operation Introduction

### Before operating tail lift:

Fully familiarize yourself with lift controls, relevant safety procedures and possible hazards signified by warning labels or highlighted in your Operator Hazard Assessment.

### iCLASS lift safety:

- Only an authorized fully trained operator must control the lift.
- Secure vehicle doors fully open, well clear of the lift platform.
- Keep within the stated maximum safe working load (SWL).
- Keep people away from the operating area (inside and outside the vehicle).
- Ensure the platform is always level see Figures 9.1.1 and 9.1.2. (horizontal, not more than 5°).
- NEVER leave the lift unattended at ground level if passengers are onboard.
- When the lift is not in use controls should be deactivated.
- Ensure that the lift is correctly stowed after loading.

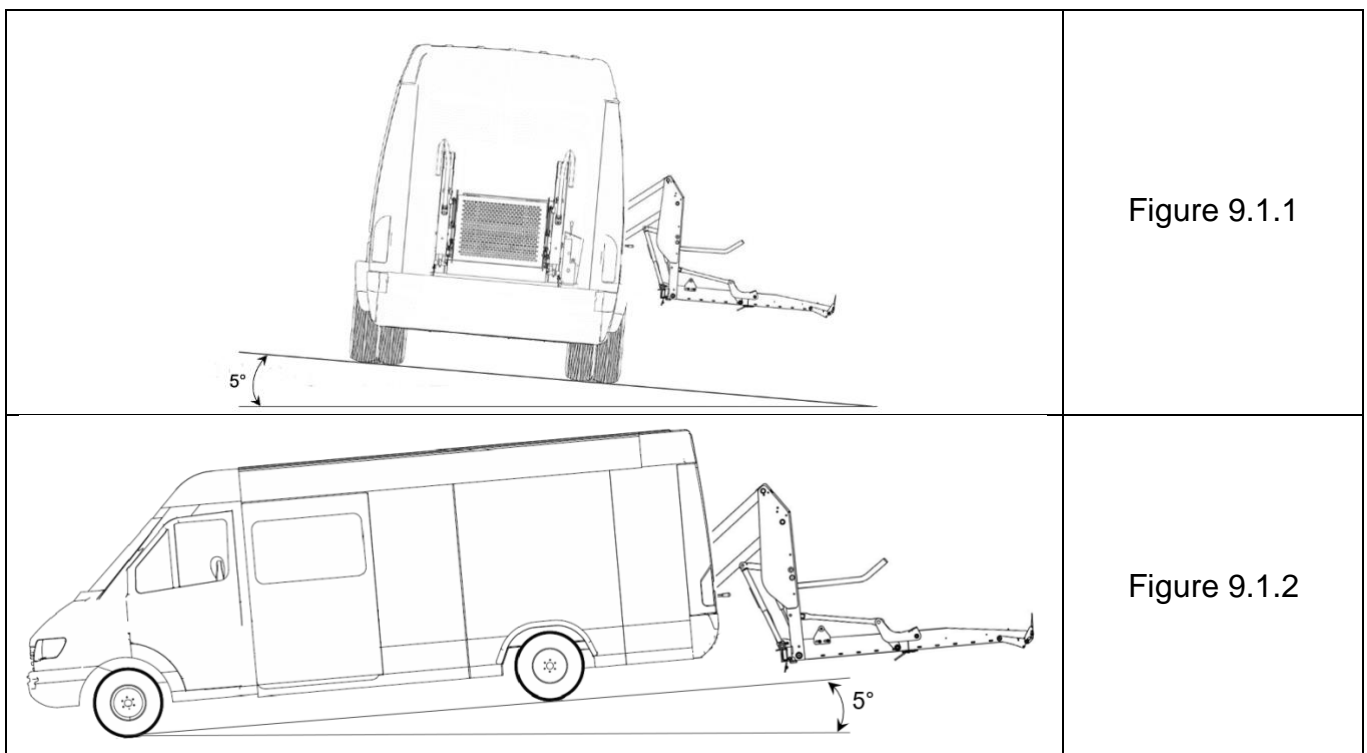

### Operators ensure that:

- Lift will lower to firm, level ground
- Scooter or powered wheelchair is not larger than the lift platform in any direction
- Tail lift is in a FULLY operational condition. Report any defects.
- Lift internal flap lands flat onto vehicle floor.
- Lift external flap is set vertically (minimum 80°) and fully operational.
- Accompany the passenger on the lift is possible, but do not overload the lift.
- You have a clear view of the lift platform before the passenger moves onto it.
- NEVER leave passengers unattended at any time.
- The passenger should not be required to operate ANY controls.

### Loading and Unloading procedure:

- Explain to passenger the sequence of movements that will occur.
- Where possible passenger should dismount the scooter / wheelchair and board the vehicle separately.
- Wheelchair user should point away from the Vehicle for loading and unloading. Connect (Buckle) the handlebar seatbelt (if fitted) as shown in Figure 9.1.1

**Note: Ensure seatbelt is snug to the occupant, as low on the abdomen / leg intersection as possible.**

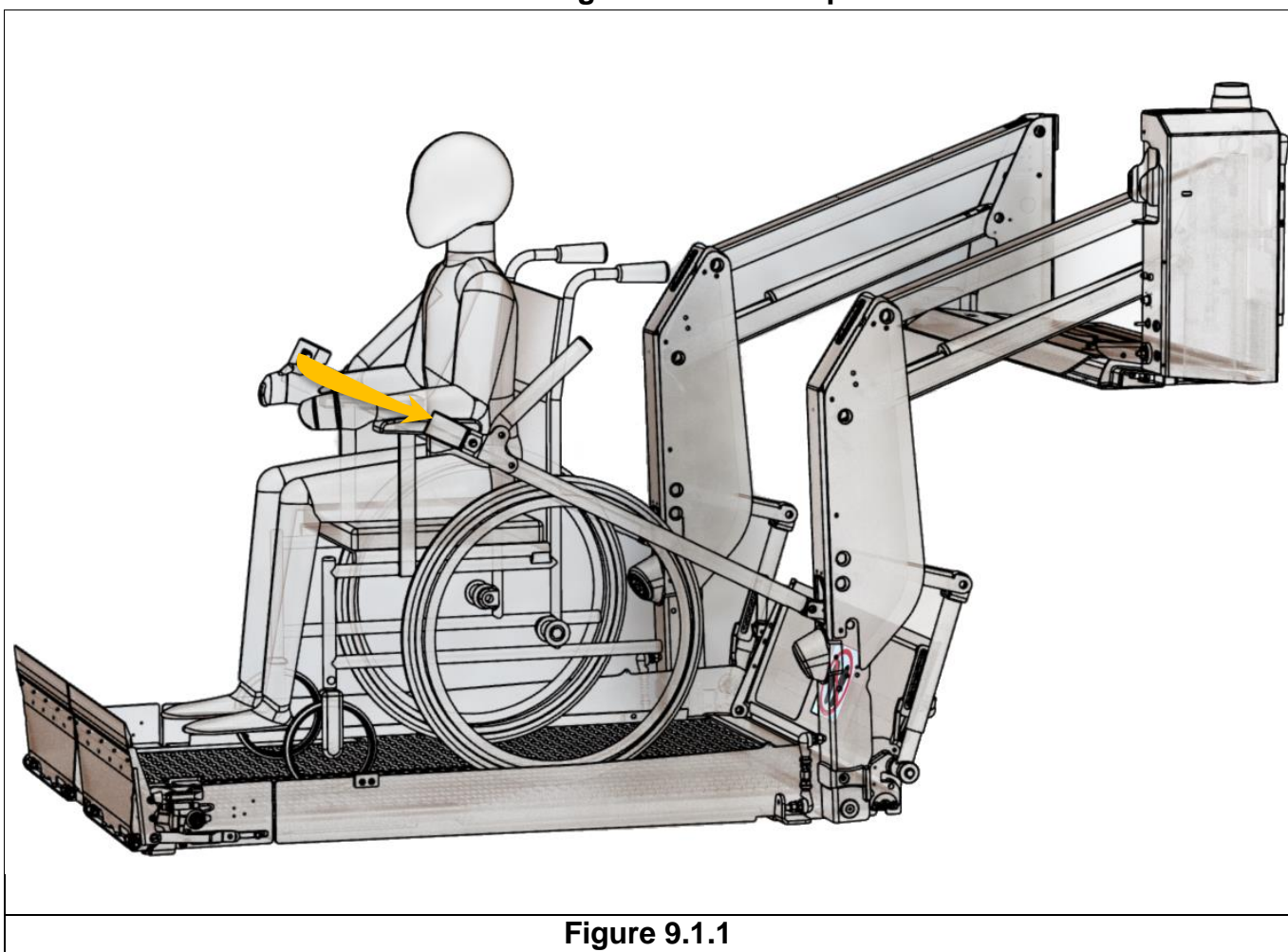

**Figure 9.1.1**

- Ensure the lift platform and area around the lift are free from obstruction.
- Ensure the lift platform is in the correct position before moving onto it.
- Scooter / Powered Wheelchair should be pushed onto the lift platform, NOT DRIVEN.
- Ensure that persons or equipment do not overhang the platform.
- BEFORE the lift begins motion Scooter / Wheelchair brakes to be applied (or wheels blocked). Wheelchair integrated occupant seatbelts should be used.
- All power to the scooter / powered wheelchair is turned OFF.
- Operate lift platform to the vehicle floor.
- Scooter / Wheelchair should be pushed off the lift platform, NOT DRIVEN
- Scooter / Wheelchair and passenger should be restrained in the vehicle using the correct the correct equipment. (Wheelchair Tiedown and Occupant Restraint System, WTORS).

***Please note:*** The transportation of scooters and large powered wheelchairs may require a NON-STANDARD tail lift size or specification. Where possible Mobility Networks can provide longer, wider platforms, higher roll-off ramps, to help combat the increased hazards related to larger passenger vehicle transportation

## 9.2 Standard Operation

In a safe area, park the vehicle on level ground, make sure there is enough room around the vehicle to enable safe operation. Open door(s) and secure fully open.

If automatic doors are fitted, refer to those instructions.



Make sure that the relative movement of the platform corresponds to each command without jamming and unusual noises. **STOP AND CHECK!** If in doubt, return lift to STOW position manually and report lift to local dealer.

### Power On:

- Toggle UP the LIFT POWER switch to the ON Position (Section 5.1) and 9.2.1
- The passenger compartment warning light confirms power to the lift is enabled.

#### LIFT POWER

ON



OFF

Fig. 9.2.1 Power On

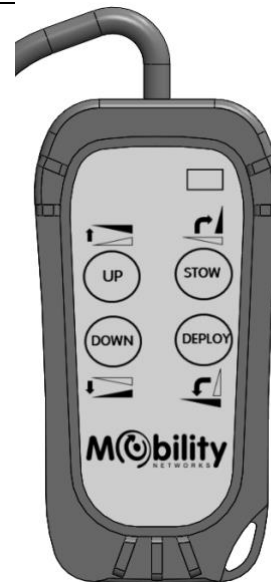

Fig. 9.2.2 Control Pendant

### Deploy Platform:

Opening is a rotational movement that moves the loading platform from the vertical (closed) position to the horizontal loading position at vehicle floor level. (Figure 9.2.3).

- Operator **MUST** stand clear of deploying lift.
- Push and hold **DEPLOY** (Figure 9.2.2) button until platform stops at the horizontal loading position on the floor of the vehicle (Figure 9.2.4).



- Release button.
- Buckle Lift Handle Seatbelt if applicable.
- The platform can now be loaded.

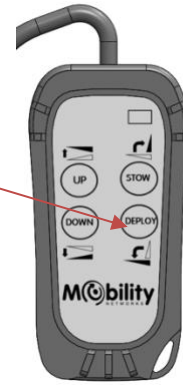

**⚠ WARNING**

Once the user is on the platform or before starting the lifting/lowering operation:  
the wheelchair **MUST BE braked.**  
**fit wheelchair occupant seatbelts.**

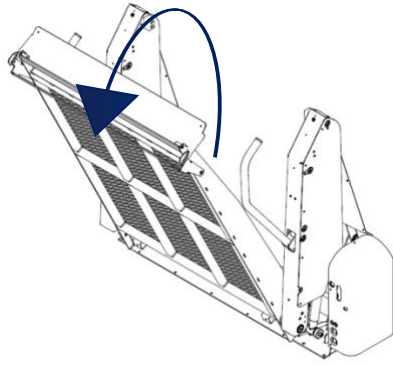

**Figure 9.2.3 Platform deploy**

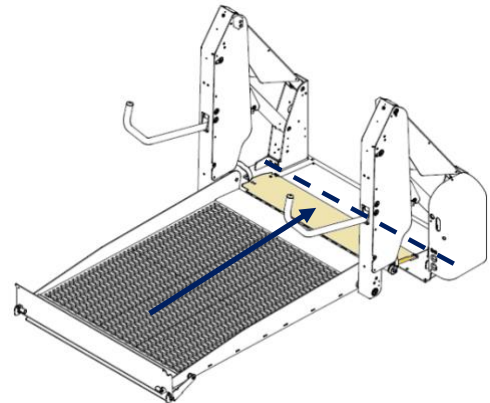

**Fig 9.2.4 Platform at vehicle floor level**

**Lowering Platform:**

- Push and hold DOWN (Figure 9.2.2) button until platform stops at the horizontal loading position on the ground.
- Release button.

Once stopped at the ground level, the passenger is ready to be loaded or unloaded.



### Raising Platform:

- Push and hold UP (Figure 9.2.2) button until platform stops at the horizontal loading position on the floor of the vehicle.
- Release button.

At this point the platform can be unloaded.

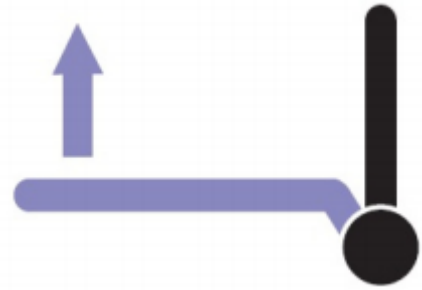

### Stowing the Platform:

After making sure that no object has been left on the loading platform, proceed as follows for the closing manoeuvre:

Stowing is a rotational movement that moves the loading platform from the horizontal position to the vertical (closed) position at vehicle floor level.

- Push and hold STOW (Fig 9.2.2) button until platform stops at the fully vertical position on the floor of the vehicle. Keep pressing until the power is interrupted.
- Release button.



### Power Off:

- Toggle DOWN the LIFT POWER switch to OFF
- The passenger compartment warning light extinguishes to confirm lift power is disabled.



To avoid draining the batteries of the vehicle, remember to disable the system after each use of the lift.

NOTE: The control pendant should be considered

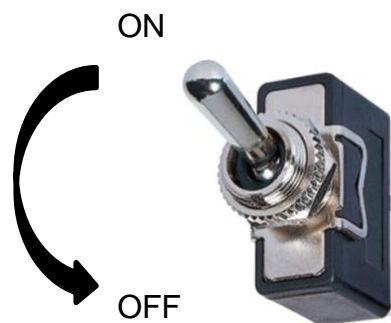

an 'enabling device'. When each button is pressed, the lift motion should be instantaneous. Removal of the operator's finger should result in immediate stop of any lift travel. If the control pendant switches do not react immediately, please report to dealer.

### 9.3 Lift Handle Safety Belt



THIS SECTION PROVIDES ADDITIONAL INFORMATION FOR LIFT HANDLE SAFETY BELT USAGE. THEY **MUST BE USED IN ADDITION** TO OTHER INSTUCTIONS IN THIS MANUAL AND IN OPERATOR'S OWN HAZARD ASSESSMENT





From Stowed Position:	From Ground Level:
Open lift to vehicle floor level	Lift raises only with seatbelt connected – with or without occupant! Move occupant into vehicle
Buckle Lift Handle Safety Belt Lift lowers only with safety belt connected – with or without occupant! Lower to ground level Un-buckle Lift Handle Safety Belt	Disconnect Safety Belt Lift can now be Stowed

### 9.4 Emergency Operation

 **WARNING**

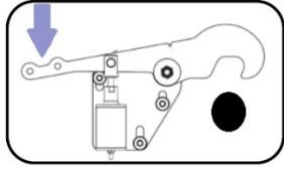
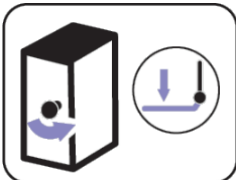
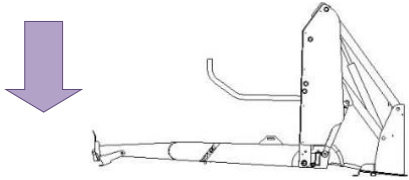
- **Note: For Emergency Operations, the lift must always be completely closed. Use the emergency hand pump to close the lift. Only when the lift is completely closed, the hook can be unlocked; this allows Emergency Operations to be performed safely.**
- Emergency manual controls are to be used to operate the lift in case of power supply failure. They are not intended for 'normal' use as an alternative to powered operation.
- Emergency manual controls must be exclusively used to help the user during lifting/lowering onto / off the vehicle and to close the opened lift, allowing to the vehicle to start again.

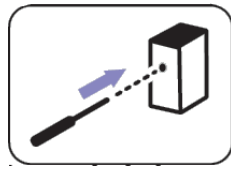
A complete **Emergency Operation** cycle is as follows:

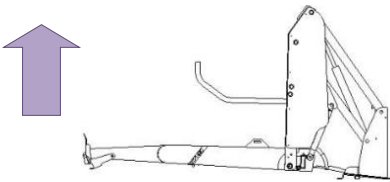
<p style="text-align: center;"><b>DANGER</b></p> <p style="text-align: center;"></p> <p><b>WITH LIFT CLOSED, RELEASE THE SAFETY HOOK AND CARRY OUT THE EMERGENCY OPERATIONS AS BELOW.</b></p> <p><b><u>BEWARE OF MOVING PARTS.</u></b></p>	
<p><b>DEPLOY/DOWN</b></p> <p>On the hydraulic unit, turn the manual override valve counterclockwise lowering using the black knob (marked by its relevant label).</p>	
<p>The platform will open and will descend until making contact with the ground or if the lowering valve is closed (by turning the knob clockwise).</p>	
<p><b>IMPORTANT</b></p> <p>Before any other operation, close the lowering valve, by turning its knob clockwise.</p>	
<p><b>UP/STOW</b></p> <p>Tighten the lever, into the threaded hole. (inside the vertical slot marked by the relevant label).</p>	
<p>Operate the pump manually alternating up / down vertical movements.</p>	
<p>The platform will reach vehicle floor level to allow user on / off the platform. Continue to operate the pump to stow the platform.</p>	

## 10.1 Torque Settings

Thread Size	Torque Setting (Nm)		
<b>HTS</b>	<b>8.8</b>	<b>10.9</b>	<b>12.9</b>
M4	2.9	4.1	4.95
M5	5.75	8.1	9.7
M6	9.9	14	16.5
M8	12	34	40
M10	48	67	81
M12	83	117	140
M14	132	185	220
M16	200	285	340

Thread Size	Torque Setting (Nm)		
<b>HTS Hex Flange</b>	<b>8.8</b>	<b>10.9</b>	<b>12.9</b>
M6	9	14.7	16.8
M8	20	35.6	41
M10	40	70.6	81

Thread Size	Torque Setting (Nm)	
<b>Stainless Steel</b>	<b>A2-70</b>	<b>A4-80</b>
M4	2.6	3.5
M5	5.1	6.9
M6	8.8	11.8
M8	21.4	28.8
M10	44	58
M12	74	100
M14	119	159
M16	183	245
M20	135	165

Thread Size	Torque Setting (Nm)
<b>BSP</b>	<b>A2-70</b>
1/8	17
1/4	35
3/8	47

## 10.2 Fastener Strength Conversion Chart

### MINIMUM STRENGTHS

**METRIC**  
(ISO 898)

**INCH**  
(SAE J429)



=



Grade: 4, 8 (4.6, 5.8)  
Tensile: 429 MPa  
(60,900 psi)

Grade: 2  
Tensile: 60,000 psi



=



Grade: 8.8  
Tensile: 830 MPa  
(120,350 psi)

Grade: 5  
Tensile: 120,000 psi



=



Grade: 10.9  
Tensile: 1040 MPa  
(150,800 psi)

Grade: 8  
Tensile: 150,000 psi



=



Grade: 12.9  
Tensile: 1220 MPa  
(176,900 psi)

Grade: ASTM-A574  
Tensile: 170,000 psi  
Note: Generally not marked

## 10.3 Electrical Schematic – iCLASS S

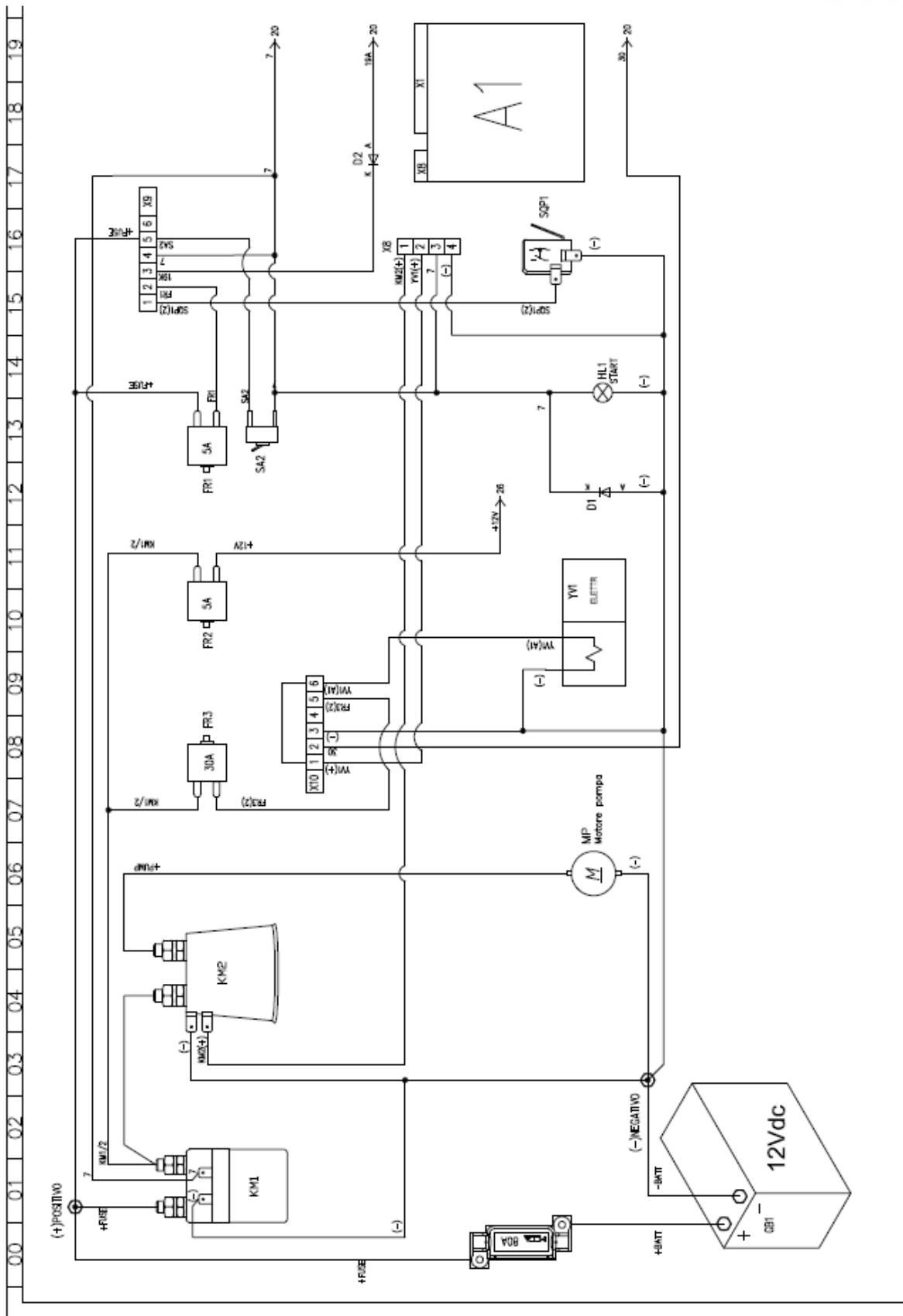



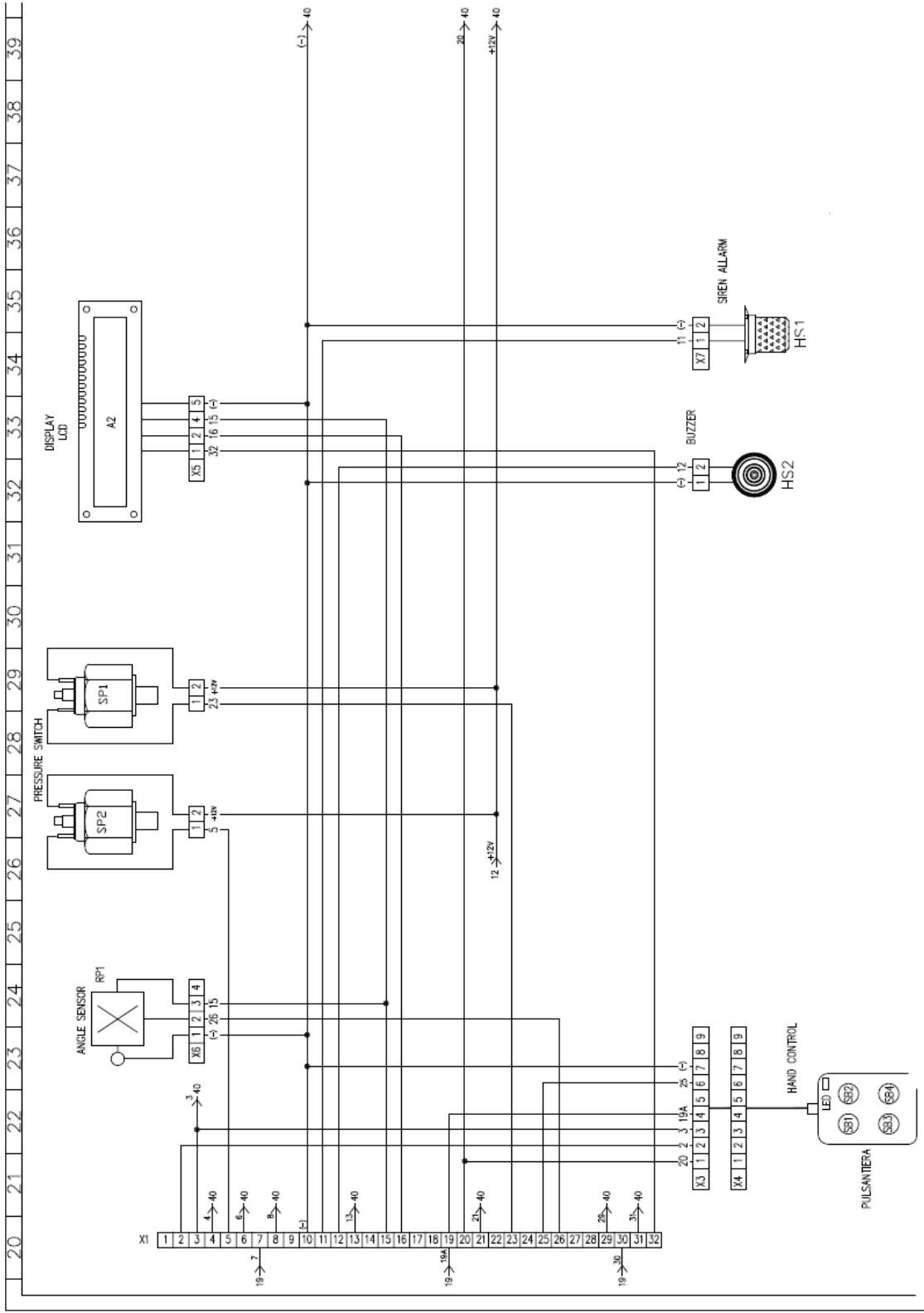

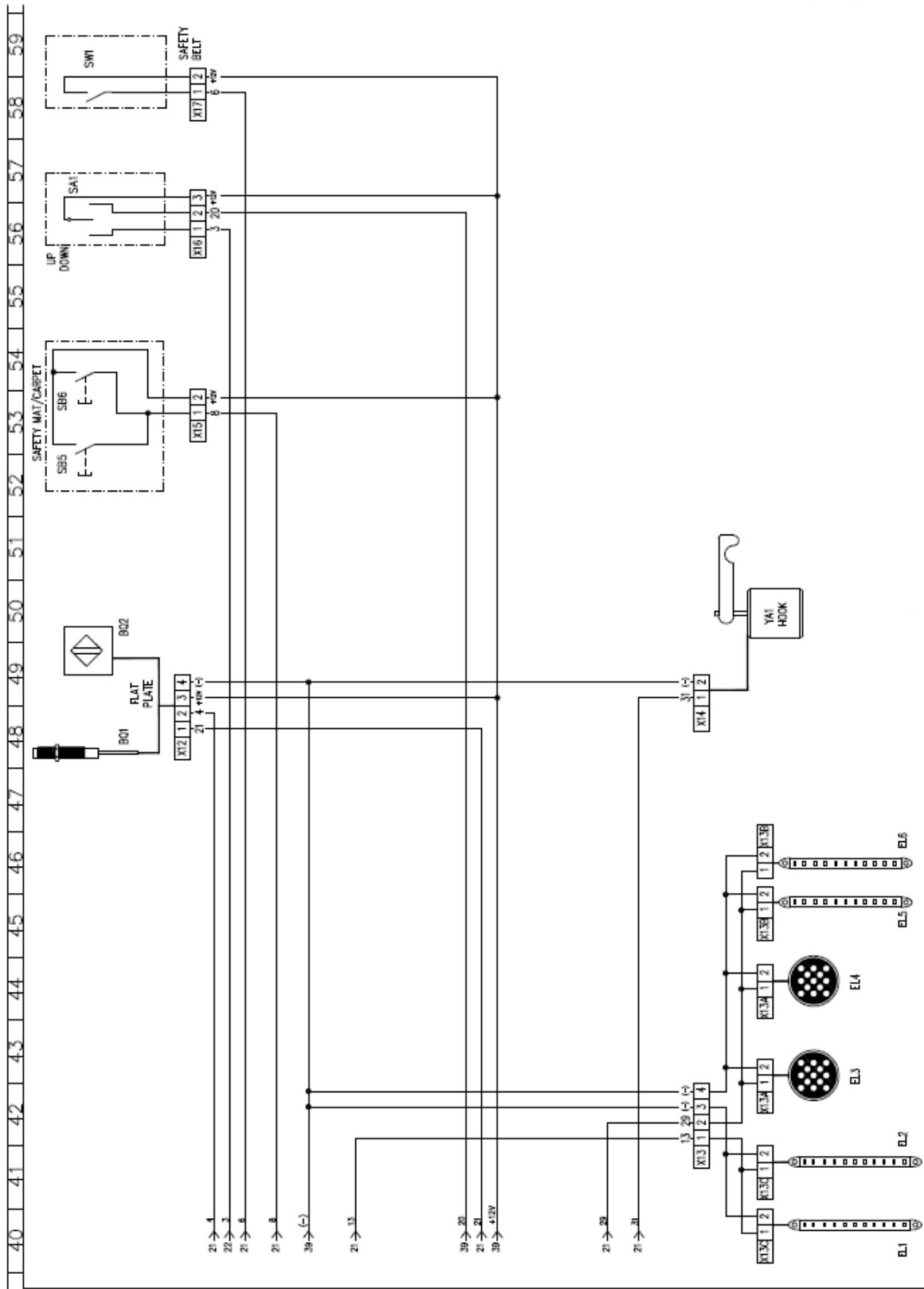

Symbol	Description	Position	Symbol	Description	Position
A1	Scheda di controllo Control interface	17->19	MP	Motore pompa Engine	06
A2	Schermo LCD display LCD	32->35	RP1	Sensore di angolo (posizione) Angle sensor	23
BQ1	Sensore di prossimità frontale Proximity sensor	48	SA1	Selettore UP, DOWN UP and DOWN switch	56
BQ2	Sensore di prossimità frontale Proximity sensor	50	SA2	Interruttore si accensione Power switch	13
EL1	Striscia LED per illuminazione ingombro laterale LED strip	40	SB1	Pulsante da pulsantiera per "STOW" Button for "STOW"	22
EL2	Striscia LED per illuminazione ingombro laterale LED strip	41	SB2	Pulsante da pulsantiera per "DOWN" Button for "DOWN"	23
EL3	Fascia LED per illuminazione pedana LED headlight	42	SB3	Pulsante da pulsantiera per "DEPLOY" Button for "DEPLOY"	22
EL4	Fascia LED per illuminazione pedana LED headlight	44	SB4	Pulsante da pulsantiera per "UP" Button for	23
EL5	Striscia LED per illuminazione pedana LED strip	45	SB5	Bordo sensibile tappeto di attracco Safety edge	52
EL6	Striscia LED per illuminazione pedana LED strip	46	SB6	Bordo sensibile per tappeto di attracco Safety edge	54
FU1	Fusibile batteria battery fuse	00	SP1	Pressostato NA per motore pompa Pressure switch (NA)	27
FR1	Termica da 5A thermal fuse 5A	13	SP2	Pressostato NC per motore pompa Pressure switch (NC)	29
FR2	Termica da 5A thermal fuse 5A	10	SOP1	Sensore di pressione Pressure switch	16
FR3	Termica da 30A thermal fuse 30A	08	SW1	Switch per cintura di sicurezza Safety belt switch	58
GB1	Batteria 12 V 12V battery	00	YA1	Elettromagnete per gancio di sicurezza Safety hook	50
HL1	Spia accensione macchina Power light	14	YV1	Elettrovalvola pressione motore pompa Engine solenoid	09->10
HS1	Lampeggiante di allarme Alarm Light	35			
HS2	Buzzer di allarme Alarm buzzer	32			
KM1	Accensione macchina Power device	01			
KM2	Avviamento motore Engine start	04			

## 10.5 iCLASS Deployment Gap Schematic



### ***i-class: P 84138R-D \_ P 84138L-D***

Dimensional table of the launch / space between vehicle and lift

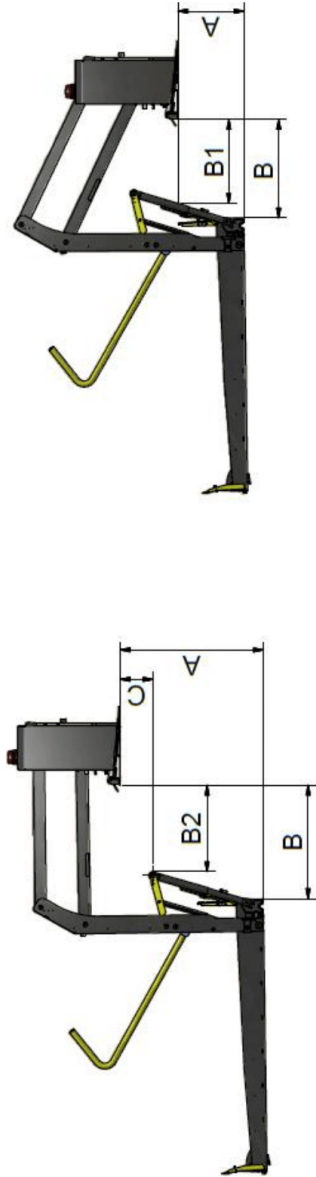

<b>A</b> (mm)	0	50	100	150	200	250	300	350	400	450	500	550	600	650	700	750	800	850	900	950	1000	1050	1100	1150	1200	1220
<b>B</b> (mm)	230	290	345	385	425	458	485	508	531	545	559	570	576	580	582	581	578	570	560	547	530	511	487	460	427	413
<b>B1</b> (mm)	345	345	345	373	382	410	420	430	435	440	438	435														
<b>B2</b> (mm)												436	442	443	443	443	438	433	423	412	396	377	355	329	298	285
<b>C</b> (mm)													30	80	128	178	228	277	327	376	426	475	525	574	623	643

<b>A</b> (inch)	0	1,97	3,94	5,91	7,87	9,84	11,8	13,8	15,7	17,7	19,7	21,7	23,6	25,6	27,6	29,5	31,5	33,5	35,4	37,4	39,4	41,3	43,3	45,3	47,2	48
<b>B</b> (inch)	9,06	11,4	13,6	15,2	16,7	18	19,1	20	20,9	21,5	22	22,4	22,7	22,8	22,9	22,9	22,8	22,4	22	21,5	20,9	20,1	19,2	18,1	16,8	16,3
<b>B1</b> (inch)	13,6	13,6	13,6	14,7	15	16,1	16,5	16,9	17,1	17,3	17,2	17,1														
<b>B2</b> (inch)													17,2	17,4	17,4	17,4	17,2	17	16,7	16,2	15,6	14,8	14	13	11,7	11,2
<b>C</b> (inch)													1,18	3,15	5,04	7,01	8,98	10,9	12,9	14,8	16,8	18,7	20,7	22,6	24,5	25,3

**i-class: SP76110L\_SP76104L\_SP66100L\_P75110L**

Dimensional table of the launch / space between vehicle and lift

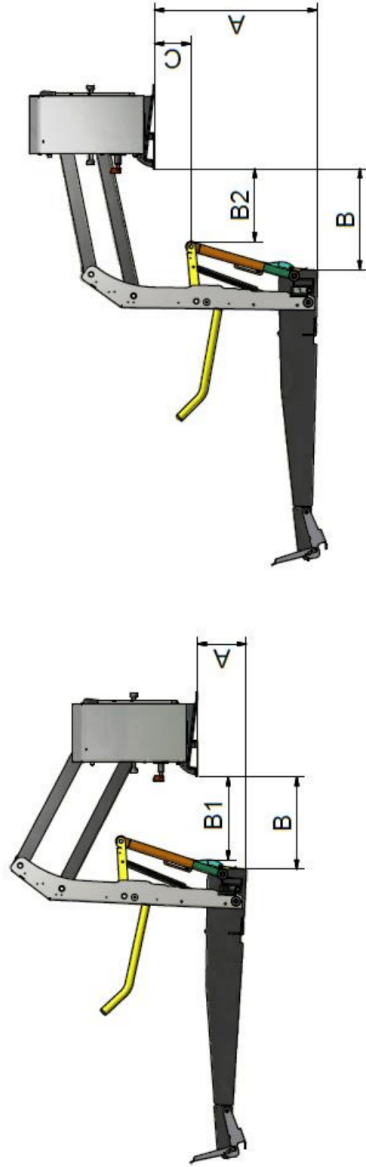

<b>A (mm)</b>	0	50	100	150	200	250	300	350	400	450	500	550	600	650	700	750	790
<b>B (mm)</b>	223	270	308	338	363	383	398	408	414	417	416	410	400	386	367	342	318
<b>B1 (mm)</b>		260	282	300	326	330	332	326	320	310	297						
<b>B2 (mm)</b>												295	285	275	258	237	218
<b>C (mm)</b>												63	112	161	211	260	300

<b>A (inch)</b>	0	1,97	3,94	5,91	7,87	9,84	11,8	13,8	15,7	17,7	19,7	21,7	23,6	25,6	27,6	29,5	31,1
<b>B (inch)</b>	8,78	10,6	12,1	13,3	14,3	15,1	15,7	16,1	16,3	16,4	16,4	16,1	15,7	15,2	14,4	13,5	12,5
<b>B1 (inch)</b>		10,2	11,1	11,8	12,8	13	13,1	12,8	12,6	12,2	11,7						
<b>B2 (inch)</b>												11,6	11,2	10,8	10,2	9,33	8,58
<b>C (inch)</b>												2,48	4,41	6,34	8,31	10,2	11,8

# 10.6 iCLASS S Hydraulic Schematic

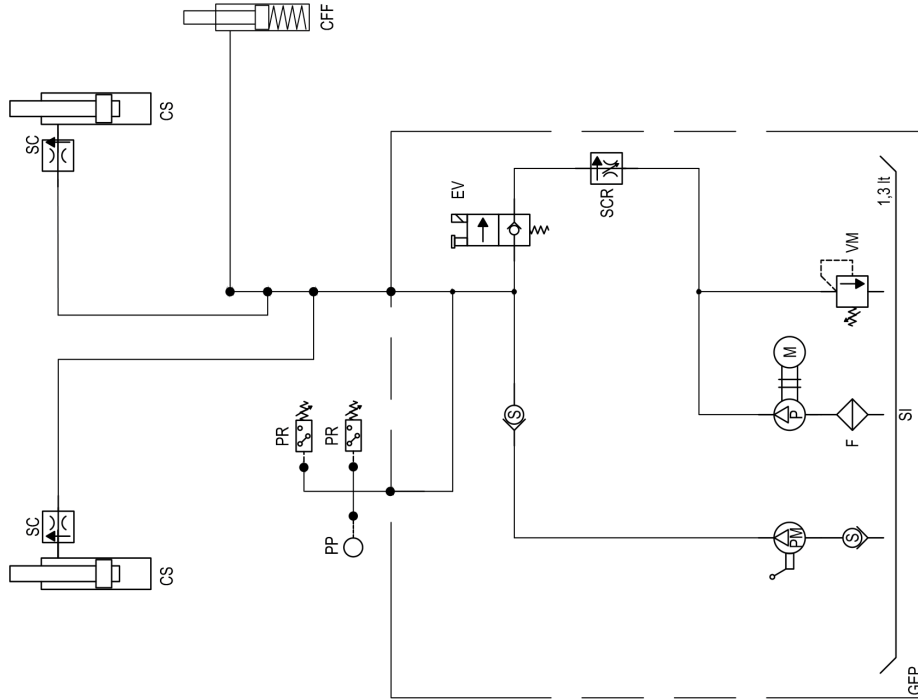

**i-class " P " FMVSS**

COD.	FUNZIONE	FUNCTION
CS	CILINDRO SOLLEVAMENTO	LIFT CYLINDER
CFF	CILINDRO RIBALTINA FRONTALE	FRONT FLAP CYLINDER
EV	ELETTROVALVOLOA DISCESA	LOWERING VALVE
F	FILTRO ASPIRAZIONE	FILTER
GEP	GRUPPO ELETTROPOMPA	ELECTRIC PUMP UNIT
M	MOTORE ELETTRICO	ELECTRIC GEAR MOTOR
P	POMPA IDRALUICA	HYDRAULIC PUMP
PM	POMPA IDRALUICA MANUALE	HYDRAULIC PUMP MANUJLA
PP	PRESA DI PRESSIONE	SOCKET PRESSURE
PR	PRESSOSTATO	PRESSURE SWITCH
S	RITEGNO	PRESSURE REDUCING VALVE
SC	STROZZATORE	FLOW RESTRICTOR
SCR	STROZZATORE COMPENSATO	COMPENSATED FLOW RESTRICTOR
SI	SERBATOIO ELETTROPOMPA	OIL TANK

Ricevato da	Data Disegno	Data Approvazione	Firma	Tensione
	23/10/2019	23/10/2019		
Autore	Controllicato da	Descrizione		
AU	AU	HYDRAULIC DIAGRAM I-CLASS "P" FMVSS		
		WHEELCHAIR LIFT I-CLASS FMVSS		
Codice Macchina	Code	Revisione		
P84138 D - FMVSS	SCIDR0036	00		



DOCUMENTO PROTETTO DA DIRITTI D'AUTORE. TUTTI I DIRITTI SONO RISERVATI. / COPYRIGHT DOCUMENT: ALL RIGHTS RESERVED.

Lift Installation and Maintenance must be performed by an approved engineer.  
 Non-compliance may result in serious personal injury, damage to the vehicle and may affect or even void the product warranty.

# 10.7 iCLASS SP Hydraulic Schematic

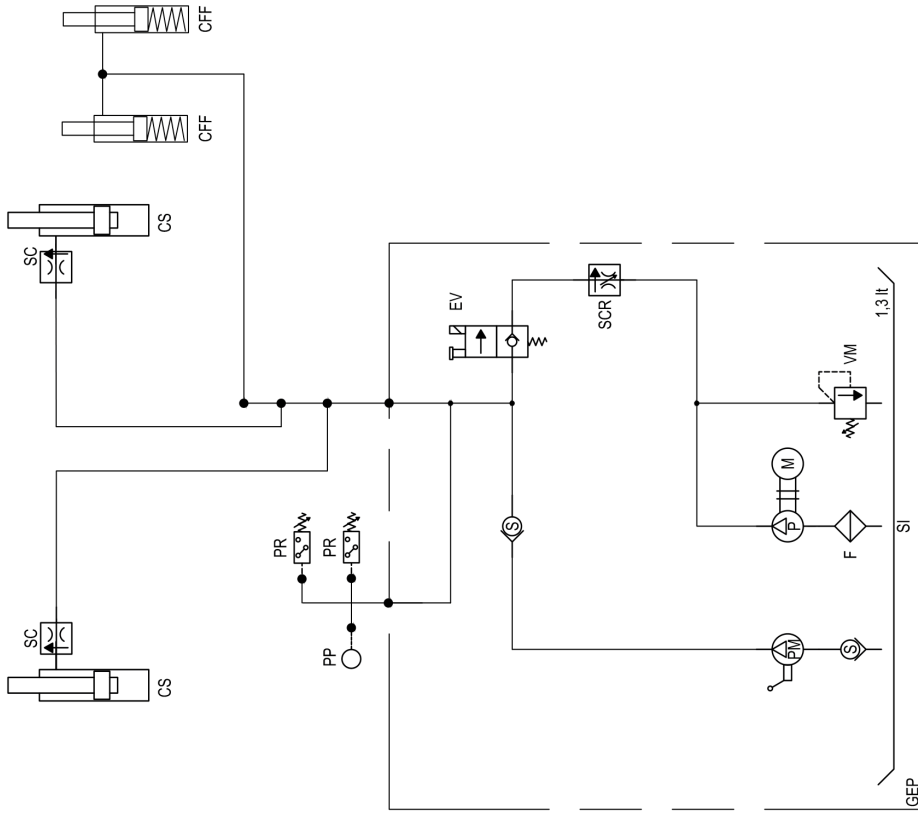

i-class "SP" FMVSS	
COD.	FUNCTION
CS	CILINDRO SOLLEVAMENTO LIFT CYLINDER
CFF	CILINDRO RIBALTINA FRONTALE FRONT FLAP CYLINDER
EV	ELETTROVALVOLA DISCESA LOWERING VALVE
F	FILTRO ASPIRAZIONE FILTER
GEP	GRUPPO ELETTROPOMPA ELECTRIC PUMP UNIT
M	MOTORE ELETTRICO ELECTRIC GEAR MOTOR
P	POMPA IDRRAULICA HYDRAULIC PUMP
PM	POMPA IDRRAULICA MANUALE HYDRAULIC PUMP MANULA
PP	PRESA DI PRESSIONE SOCKET PRESSURE
PR	PRESSOSTATO PRESSURE SWITCH
S	RITEGNO PRESSURE REDUCING VALVE
SC	STROZZATORE FLOW RESTRICTOR
SCR	STROZZATORE COMPENSATO COMPENSATED FLOW RESTRICTOR
SI	SERBATOIO ELETTROPOMPA OIL TANK

Ricevato da		Data Disegno	Data Approvazione	Firma	Tensione
		23/10/2019	23/10/2019		
		Autore	Descrizione		
		AU	HYDRAULIC DIAGRAM I-CLASS "SP" FMVSS		
		Controllato da	WHEELCHAIR LIFT I-CLASS FMVSS		
		Code Macchina	SP90148	FWSS	SCIDR0037
					Revisione 00

DOCUMENTO PROIETTO DAI DIRITTI D'AUTORE. TUTTI I DIRITTI SONO RISERVATI. / COPYRIGHT DOCUMENT. ALL RIGHTS RESERVED.

Lift Installation and Maintenance must be performed by an approved engineer.  
 Non-compliance may result in serious personal injury, damage to the vehicle and may affect or even void the product warranty.

## 10.8 iCLASS FP Hydraulic Schematic

COD.	FUNZIONE	FUNCTION
CS	CILINDRO SOLLEVAMENTO	LIFT CYLINDER
EV	ELETTRIVALVOLA DISCESA	LOWERING VALVE
F	FILTRO ASPIRAZIONE	FILTER
GEP	GRUPPO ELETTROPOMPA	ELECTRIC PUMP UNIT
M	MOTORE ELETTRICO	ELECTRIC MOTOR
P	POMPA IDRAULICA	HYDRAULIC PUMP
PM	POMPA IDRAULICA MANUALE	HYDRAULIC PUMP MANUAL
PP	PRESA DI PRESSIONE	SOCKET PRESSURE
PR	PRESSOSTATO	PRESSURE SWITCH
S	RITEGNO	PRESSURE REDUCING VALVE
SC	STROZZATORE	FLOW RESTRICTOR
SCR	STROZZATORE COMPENSATO	COMPENSATED FLOW RESTRICTOR
SI	SERBATOIO ELETTROPOMPA	OIL TANK
VM	VALVOLA DI MASSIMO IMPIANTO	RELIEF VALVE

Pagina / 1

Riconvocato da

Data Disegno	23/10/2019	Data Approvazione	23/10/2019	Firma	Tensione
Autore	AU	Descrizione	HYDRAULIC DIAGRAM I-CLASS "FP" FMVSS		
Controllato da	AU	WHEELCHAIR LIFT I-CLASS FMVSS			Revisione
Codice Macchina	FP80150 - FMVSS	Codice	SCIDR0038		
					Revisione
					00

DOCUMENTO PROTETTO DAI DIRITTI D'AUTORE. TUTTI I DIRITTI SONO RISERVATI. / COPYRIGHT DOCUMENT. ALL RIGHTS RESERVED.

Lift Installation and Maintenance must be performed by an approved engineer.  
Non-compliance may result in serious personal injury, damage to the vehicle and may affect or even void the product warranty.



## 10.9 Hydraulic Routing

**GREEN:** Feed to Outer Barrier

**YELLOW:** Feed to Arm cylinders

**BLUE:** Breather Hoses

**REFER ALSO TO SPARE  
PARTS SECTION FOR MORE  
DETAILS**

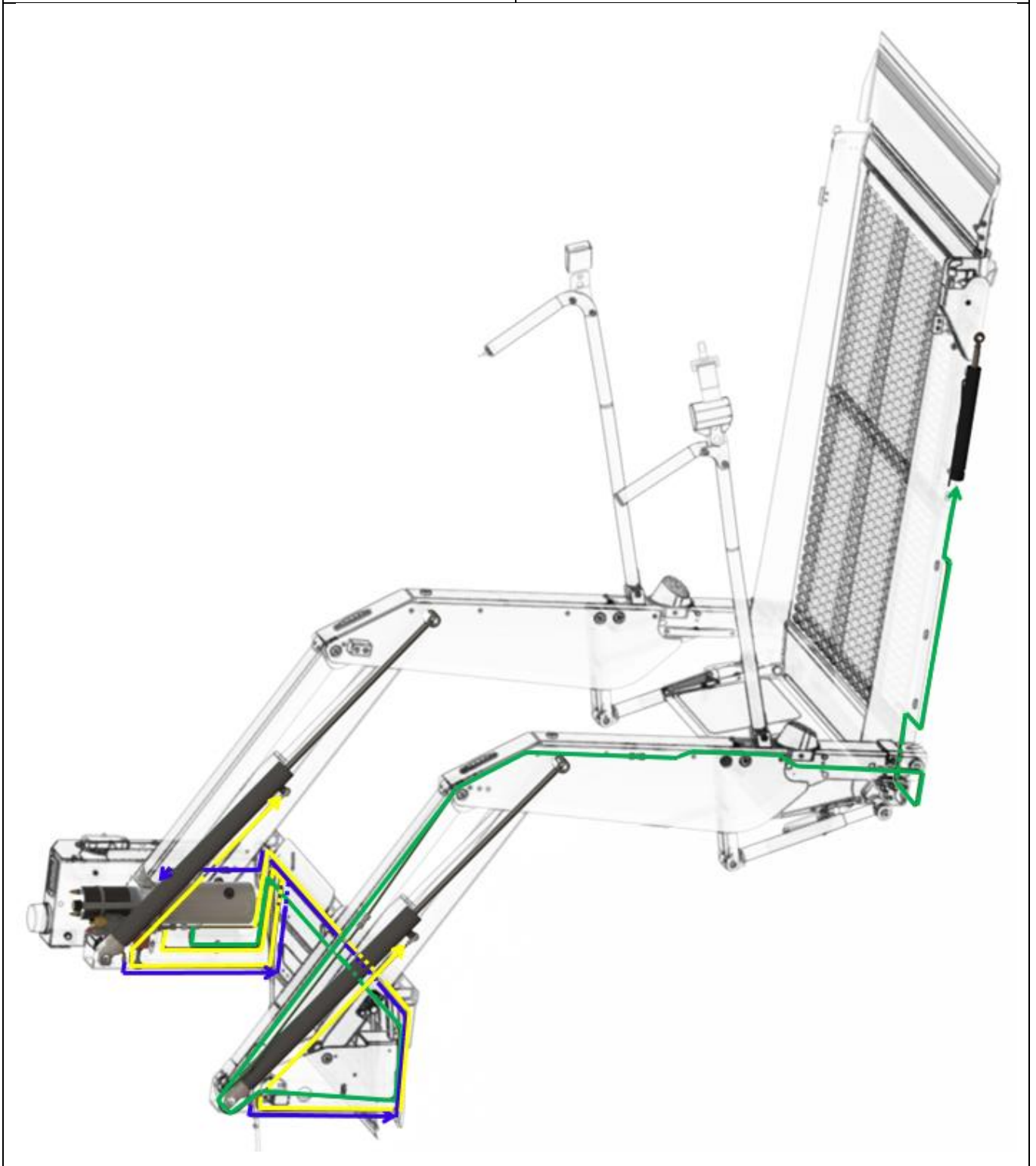

## 11.1 Setting 'Full Operation Mode' (non-Mobility Networks – Smart Lift App method)

**Full Operation Mode** Purpose: To ensure that the proper checks were made by the engineers at the factory & by the final installer.

**Safety Mode** delays or stops the operation of the lift if it was not taken out of safety mode or if one of the lift modules and / or sensors has started malfunctioning.

If activated, **Safety Mode** delays the Deploy operation by 10 seconds, activates the buzzer and the LCD displays '**SAFETY MODE**' every time the lift is powered on. After initial 10 seconds delay, the lift will resume operation but will reset the delay every time the lift is powered off.

Safety mode will stop all operations if the temperature of the ECU exceeds 80°C (176°F), Angle Sensor is disconnected or malfunctions, or if the battery voltage is low.

All lifts leave the factory with **Safety Mode** active and it is the Installer's responsibility to put the lift in **Full Operation Mode**. Upon finishing installation, it is recommended that the Installer pairs the lift to the **Mobility Networks – Smart Lift** App and sets the lift in **Full Operation Mode**. The date and time will also be recorded and the App will forward this info to Manufacturer/Customer as a record of successful installation.

Alternatively, switching between **Full Operation Mode** and **Safety Mode** can be set using the wired remote as follows:

1. Power OFF ECU
2. Press and hold buttons DEPLOY & DOWN on the hand control
3. Power ON ECU
4. While holding DEPLOY & DOWN wait 5 seconds
5. On the LCD the message will display:  
UPDATING SAFETY MODE X  
X- will be the current value of the SAFETY MODE
6. 5 second timer starts
7. If SAFETY MODE is 0 and you want to KEEP lift in '**SAFETY MODE**', power off the ECU now.
8. If SAFETY MODE is 0 and you want to ENABLE '**FULL OPERATION MODE**', wait 5 seconds.
9. If SAFETY MODE is 1 and you want to put lift in '**SAFETY MODE**', wait 5 seconds
10. After 5 seconds the LCD message will display:  
SAFETY SET= [X]  
REBOOT  
X- will be the current value of the SAFETY mode

## 11.2 Electrostatic Precautions

Electrostatic discharge or ESD is the sudden flow of electricity between two objects. ESD occurs when an object with a static electricity charge nears an object with a lower charge. When removing and working on the ECU, make sure to ground yourself on the metal case.

Static electricity commonly builds up when there is friction between two materials. Some of the components inside the ECU are sensitive to ESD and could be damaged.

The best method to prevent ESD is using a grounding wrist band, mat or table. They are designed to dissipate the static charge safely.

Whenever working inside the power pack disconnect the battery and all power supply cords before opening. Cycle and hold the power button to ON for five seconds after everything is disconnected. This will help prevent an unexpected shock and help eliminate sources of ESD.

Next, equalize the charge between yourself and the ECU. Touch the ground contact inside the power pack for two seconds before handling the circuit to discharge any residual electricity stored in your body.

Avoid clothing which conducts static electricity like wool and synthetic fabrics. It's also helpful to remove metal jewelry. Collect all the tools and supplies you'll need before you open the power pack. You may create unexpected charge each time you walk away.

If you have to open the ECU cover, avoid touching the surface of the circuit board. Special care should be taken to ensure the pins of the components inside the circuit board are not touched. Install the circuit board into the correct position using only as much pressure is needed to snap it into place. Never force the board into a position, and avoid bending it.

Only handle the ECU board if you are a trained installer.

When handling the circuit board, if possible, only touch the edges.

When handling the onboard components (SD Card and battery) make sure you are grounded.



**WARNING**

Failure to observe these precautions may cause irreversible damage to the ECU and / or its components.

## 11.3 Firmware Updates

The SD Card Update can be summarized as follows:

1. Remove the ECU from the Power Pack (See Section 12.13).
2. Remove the ECU Cover.
3. Copy the UPDATE.bin file (supplied) on to a micro SD card
4. Insert the SD card into the micro SD card holder on the ECU circuit board.
5. Re-connect the ECU to the Power Pack (do not finally fit the ECU into the powerpack until it is fully tested).
6. Power ON ECU, make sure it has updated correctly and the lift functions as expected. Once successful, re-fit the ECU mounting screws and Power Pack cover.
7. The location of the SD card on ECU board is shown by the blue arrow in Figure 11.3.1

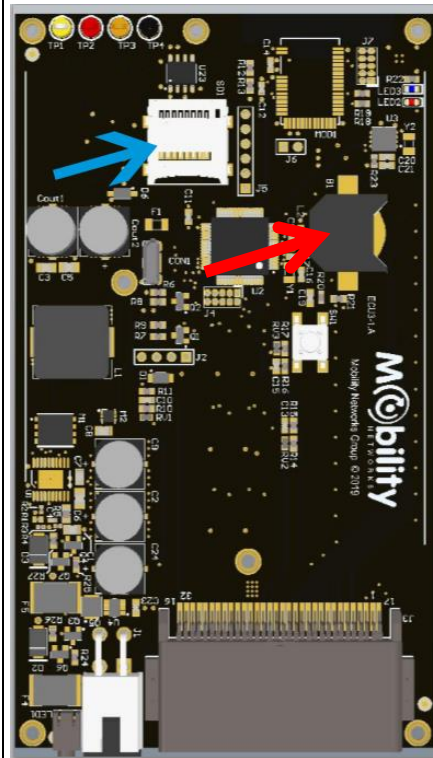

The flowchart is shown below:

Above: Figure 11.3.1

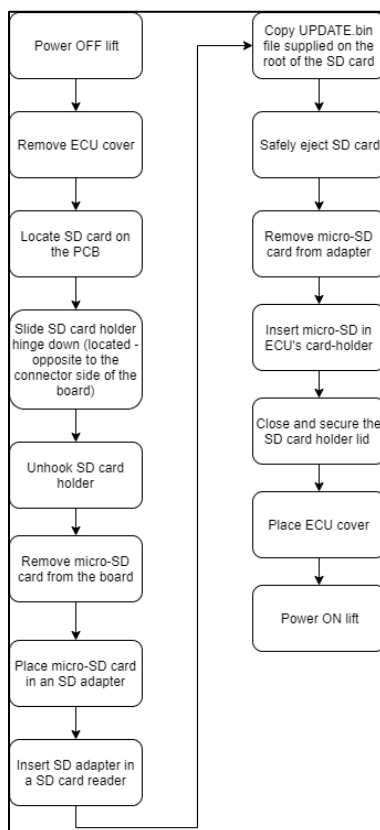

## 11.4 Firmware Update using the Mobility Networks App

The firmware update using the Mobility Networks App can be summarized as follows:  
Users can download the latest version of the lift firmware which in turn directly upgrades the lift's functionality.

1. Power OFF lift
2. Open the Mobility Networks Smart App
3. Pair the Mobility Networks Smart App with your lift
4. Enter the PIN as it is displayed on the LCD
5. Tap on side menu and navigate to the *Firmware update* page
6. On the *Firmware update* page tap on the icon to begin the firmware update process.

Note 1. The firmware update will take anywhere between 5 to 7 minutes. Your saved settings such as floor / stow position will remain unchanged.

Note 2. As an Installer, you have the option to change the type of firmware (iCLASS 2021 & ADA / iCLASS FMVSS / FP / S).

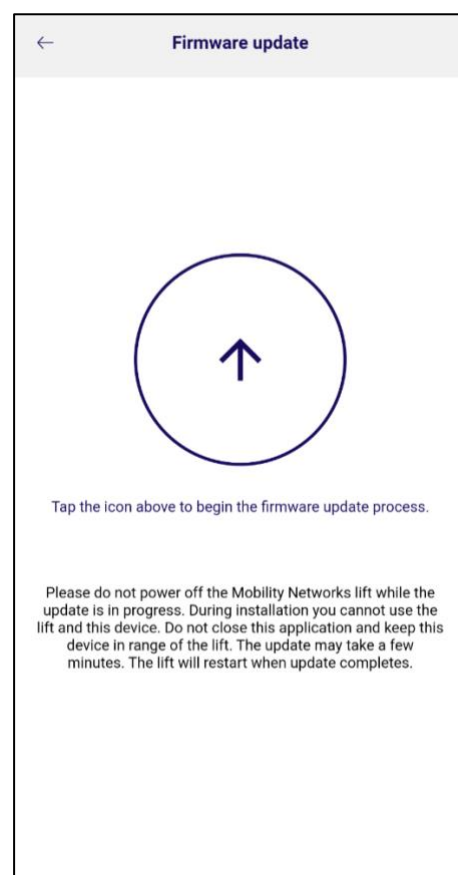
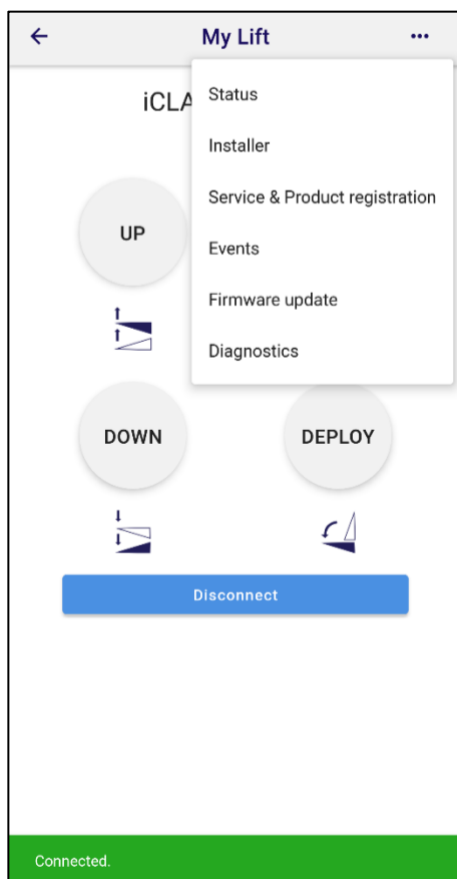

## 11.5 ECU Pin Configurations

### 32-Pin Connector

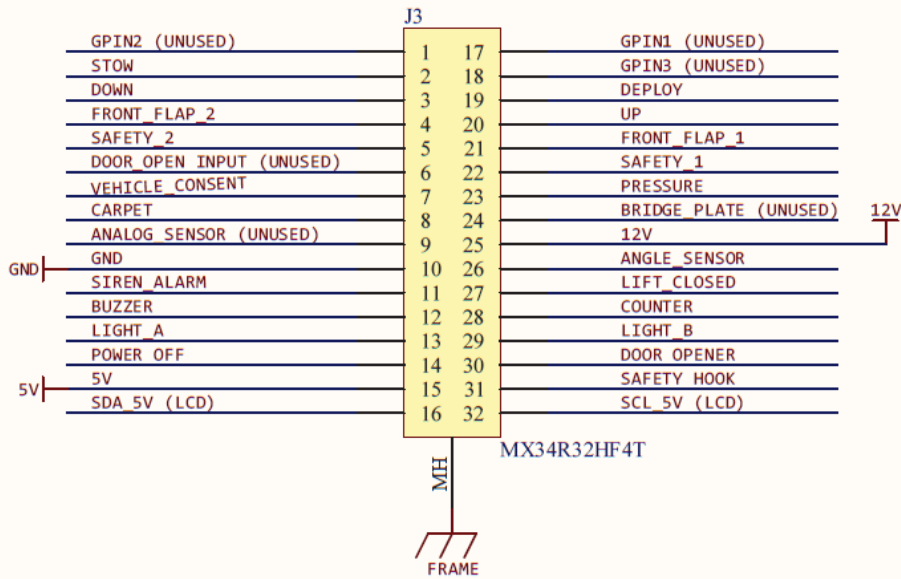

Note: Supply Voltage can be 12V or 24V depending on lift configuration

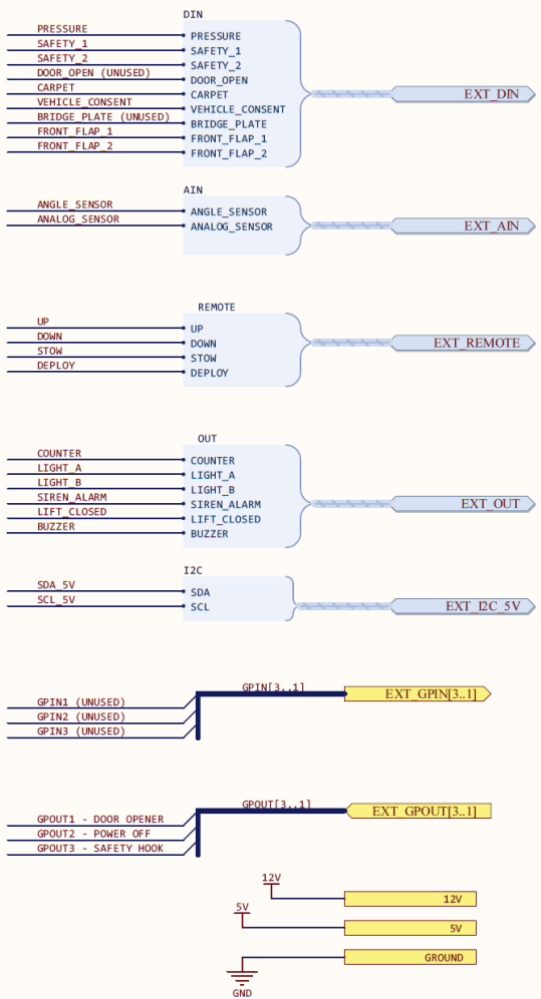

Note: Supply Voltage can be 12V or 24V depending on lift configuration

## 4-Pin Connector (Battery Input, Relay & Solenoid)

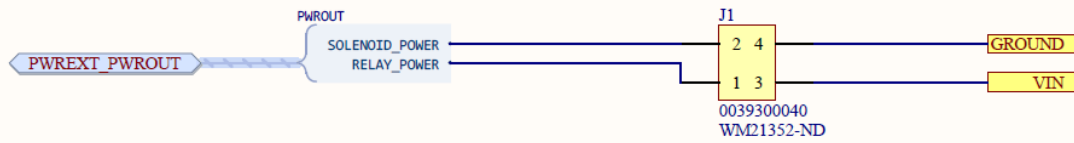

## 11.6 RTC - Battery Replacement

If the ECU clock is no longer accurate or losing time, change the RTC battery. After replacing the battery, it is necessary to pair the lift with the Mobility Networks app to reset the clock.

Refer to Figure 11.3.1.

The **red arrow** shows the battery position on the ECU board.

1. Remove the ECU from the Power Pack (See Section 12.13).
2. Remove the ECU Cover (See Section 12.14).
3. The battery is installed with +positive side up.
4. To remove the RTC battery, use a non-metallic pry tool to push the battery out of its slot.
5. Wait at least thirty seconds before replacing the battery.
6. Replace the battery (1220 type) in the same socket it was removed from. Observe correct polarity.



## 11.7 ECU Display Messages

<b>Information is displayed on the LCD as the following example:</b>	
("CHK?","SAFETY MAT")	
CHK?	displayed on the first line of the LCD
SAFETY MAT	displayed on the second line of the LCD
<b>Error Messages are summarized below:</b>	
("CHK?","SAFETY MAT")	Safety mat pressed
("CHK?","VEHICLE CONSENT")	Vehicle consent input disconnected
("CHK?","DISCONNECT BELT")	When deploying the lift, the safety belt must be un-latched and the belt retracted fully
("CHK?","PRESSURE SWITCH")	When stowing if pressure microswitch is pressed (will be displayed briefly)
("CHK?","RETURN FLOOR LVL")	When stowing - pressure microswitch was pressed (will not allow stowing if pressure microswitch was pressed at any time when stowing) <b>Platform must return to floor level</b>
("CHK?","SAFETY SWITCH")	Occurs when lifting – if platform is not levelled
("CHK?","BELT")	Occurs when lifting / lowering, safety belt installed and belt is not connected (latched). Connect (latch) safety belt to allow lift to operate.
("CHK?","FRONT FLAP2")	When lifting / lowering - if outer barrier sensor response is not correct
("CHK?","FRONT FLAP1")	When lifting / lowering - if outer barrier sensor response is not correct
("CHK?","SAFETY2")	When lifting – if the pressure switch for the outer barrier is triggered: <ul style="list-style-type: none"> <li>- wheelchair on outer barrier</li> <li>- adjust pressure switch</li> <li>- disconnected or faulty cable</li> </ul>
("SAFETY MODE","HIGH TEMP")	Triggered any time that at any time if internal ECU temp exceeds 80°C (176°F)
("SAFETY MODE","ANGLE SENSOR")	Triggered any time if the signal received from the angle sensor is faulty: <ul style="list-style-type: none"> <li>- disconnected sensor</li> <li>- broken sensor</li> </ul>
("SAFETY MODE","LOW BAT VOLTAGE")	Triggered any time if the battery voltage goes under 9V (with the relay LOW)



<b>ECU Display Messages are summarized below:</b>	
("UPDATING", "FLOOR LVL")	Displayed when DOWN & UP buttons are pressed and lift is powered ON
("FLOOR SET= ")	Displayed after a 5 second delay when setting the FLOOR LEVEL
("UPDATING", "STOW LVL")	Displayed when STOW & DEPLOY buttons are pressed and the lift is powered ON
("STOW SET= ")	Displayed after a 5 second delay when setting the STOW LEVEL
("UPDATING", "SAFETY MODE")	Displayed when DEPLOY & DOWN buttons are pressed. The lift will cycle between SAFETY MODE ON / OFF after a 5 second delay
("SAFETY SET= ")	Displayed after a 5 second delay when updating the SAFETY MODE. 1 = enabled / 0 = disabled
("UPDATING", "DEBUG STATUS")	Displayed when pressing the UP & STOW buttons. The lift will cycle between DEBUG ON / OFF after a 5 second delay
("DEBUG SET= ")	Displayed after a 5 second delay when updating the DEBUG MODE. 1 = enabled / 0 = disabled
("WRONG BUTTONS")	User tried to power ON the lift with an unrecognized combination of buttons
("iClass-F" or "iClass-FP" or "iClass", "SERIAL NUMBER")	Lift type and Serial Number supplied by the factory is displayed at every lift power ON
("PIN:", "1234")	The PIN is displayed every time the Mobility Networks Smart Lift app pairs with the lift
("FW: 1.2.1", "B: 13.1 V")	Version number and battery voltage is displayed at every lift power ON
("Service due soon!")	Displayed after the service counter goes above 4500 cycles, signaling that the service interval will soon be reached
("Service due now!")	Displayed after the service counter goes above 5000 cycles, signaling that the service interval was reached
("Counter: 1", "Closed" or "Deploying" or "Deployed" or "Lowering" or "Lowered" or "Lifting" or "Stowing")	Displayed in normal lift operation – the cycle counter and the state of the lift.
("REBOOT")	Displayed after an action that requires the ECU to be powered off

("UPDATING...", "DO NOT POWER OFF")	ECU Firmware Update using the Mobility Networks App is underway. Do not power off the lift while the update is in progress. During installation you cannot use the lift nor your device. Do not close the application and keep the device in range of the lift. The update will take a few minutes to complete and the lift will restart when the update completes.
("REPLACE NOW", "DAMAGED ECU")	Replace ECU, short circuit detected.

## 12.1 Service Intervals

Service Interval	Service Type	Complete Service Schedule for 4000 cycles or 12 months (whichever comes first)
Daily	Daily	
2 Weeks	2 Weeks	
1000 cycles (or 3 months - whichever first)	A	
2000 cycles (or 6 months - whichever first)	B	
3000 cycles (or 9 months - whichever first)	A	
4000 cycles (or 12 months - whichever first)	C	
8000 cycles (or 24 months - whichever first)	D	

## 12.2 Daily Checks

Lift Inspection checks are required on a DAILY basis by the lift operating company. The working life of the lift will be greatly prolonged if these steps are adhered to:

Daily Inspection Check List	Date:
Lift	
Vehicle #	
Engineer's Name:	
Customer Name:	
Customer Address:	
Phone #	
Check	OK ?
Visually Check Condition of Safety Belt. Deploy all webbing, check both sides and that stitching is in good condition (if fitted)	YES / NO
Visually check hydraulic fluid level using eyeglass	YES / NO
Visually check for any leaks or damage	YES / NO
Check for obvious signs of damage, and notify manager if necessary	YES / NO
Operation instruction labels are visible?	YES / NO
Check the hand pump handle is present	YES / NO
Handset control is working correctly and no signs of damage?	YES / NO
Platform is clean and dry?	YES / NO

Ensure the Handrail guards are present and undamaged	YES / NO
Check correct operation of Bridging Device / Inner Roll Stop	YES / NO
Check correct operation of Outer Barrier	YES / NO
Check warning lights are operating correctly	YES / NO

**IF IN DOUBT CONTACT THE MANUFACTURER**

### 12.3 Checks to be performed every 2 Weeks

**Perform the following checks every 2 Weeks:**

Check	OK ?
Lubricate relevant parts with ACF-50	YES / NO
Check under the vehicle for damage and / or corrosion and that all fasteners are present and tight	YES / NO
Check condition of all cabling	YES / NO
Check that the vehicle interlock operates correctly – the lift cannot move out of stow position unless the interlock is operational	YES / NO
Check that the bridge plate warning system operates when it is occupied	YES / NO
Check that the outer barrier operates correctly when occupied	YES / NO
Check that outer barrier locks engage correctly. If not seek technical assistance.	YES / NO
Check that inner barrier locks engage correctly. If not seek technical assistance.	YES / NO
Check correct operation of emergency (manual) pump	YES / NO
With the lift is on the ground check that the oil level has not dropped, if so, check system for leaks and make necessary repairs.	YES / NO

### 12.4 Service Type A

Regular lift maintenance is recommended at the time or the cycles specified in 12.1 by the lift operating company. The working life of your lift will be greatly prolonged if these steps are adhered to.

This should include the following:

1. Visually Check Condition of Safety Belt. Deploy all webbing, check both sides and that stitching is in good condition (if fitted)
2. Check for obvious signs of damage and corrosion, replace parts as necessary.
3. Check the operation and stowing of the lift.
4. Check the rear roll-off-ramp operation. Lubricate with silicone spray.
5. Check bridging plate operates correctly, adjust as necessary.
6. Check handrail operation and security. If components are corroded, they should be replaced due to potential hazard to users! Check location pivot pins, these should be fully secure.
7. When cleaning the vehicle wash the working platform of the lift in accordance with instructions Section 13.
8. Check Up/ Down pump for fluid leaks and loose/ corroded electrics. Top up reservoir (with lift at ground position) with recommended Hydraulic Oil, do NOT overfill. Coat any exposed electrics with dielectric grease (to protect).
9. Lubricate lift in accordance with instructions Section 14.

**IF IN DOUBT, CONTACT THE MANUFACTURER**

## 12.5 Service Type B

**Regular lift maintenance is recommended at the time or the cycles specified in 12.1 and records kept. They are required for warranty claim. Without them the warranty may be void.**

### For Factory Trained Lift Engineers

As Service Type A checks plus:

Task	Description	Check Box When Completed
1	Check arm pivot pins, bushes, bearings and retaining grub screws, in particular the check the arm pin for wear and that fasteners are secure and torqued correctly.	
2	Check cylinder rod clevis and grub screws.	
3	Check the outer barrier hydraulic cylinder(s). See section 12.7	
4	Check other cylinders for oil leaks. Replace piston seal if excessive oil leaking from the cylinder.	
5	Check electrical cabling for signs of wear, if split or damaged this must be replaced!	
6	Check platform wear strips (on underside of platform extension surface) for wear, or 'fastening protrusion' replace if necessary.	
7	Check bridging plate for correct operation. The bridging plate must land flush with the vehicle floor and NOT form a trip hazard.	
8	Check that the platform does not have a side-to-side 'skew'. If a 'skew' is present the lifting cylinders should be adjusted.	
9	Check that the lift mounting brackets and track bolts are tight / secure and free from damage. Corrosion in this area of the lift is likely to occur, however if in an advanced state, components should be exchanged for new items.	
10	Check manual hand pump operation (see Auxiliary Hand Pump Operation Procedure), lubricate all pivot points. REMEMBER TO RETURN ANY MANUAL OVERRIDE KNOBS TO THEIR CLOSED POSITION.	
11	Check the handset wiring by powering the lift whilst manipulating the cable in any direction.	

***IF IN DOUBT CONTACT THE MANUFACTURER***

The following should be performed during Commissioning and at the Service Type B check:

<b>A -Threshold Warning Mat Adjustment</b>		
<b>Position</b>	<b>5kg – No Sensor Trigger (check box to confirm)</b>	<b>8kg – Sensor Triggers (check box to confirm)</b>
<b>1</b>		
<b>2</b>		
<b>3</b>		
<b>4</b>		
<b>5</b>		
<b>6</b>		
<b>Other Checks</b>		<b>(check box to confirm)</b>
<b>B - Outer Barrier Function Check and Adjustment Performed</b>		
<b>C - Platform Stow Check and Adjustment Performed</b>		
<b>D - Inner Barrier Function Checked and Adjustment Performed</b>		

**12.6 Service Type C**

**Perform the same checks as Service Type A and B plus:**

Check Hydraulic Fluid Level, Check the condition of all pins, arms and bearings, gas springs, power cables, fixing to vehicle, decals, anti-skid.

## 12.7 Outer Barrier Cylinder Check

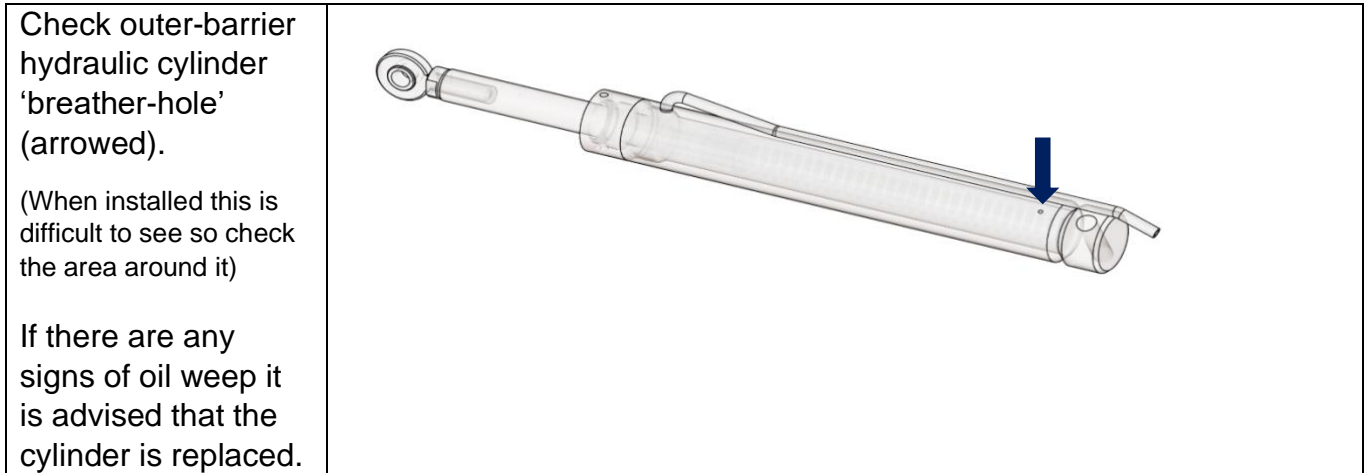
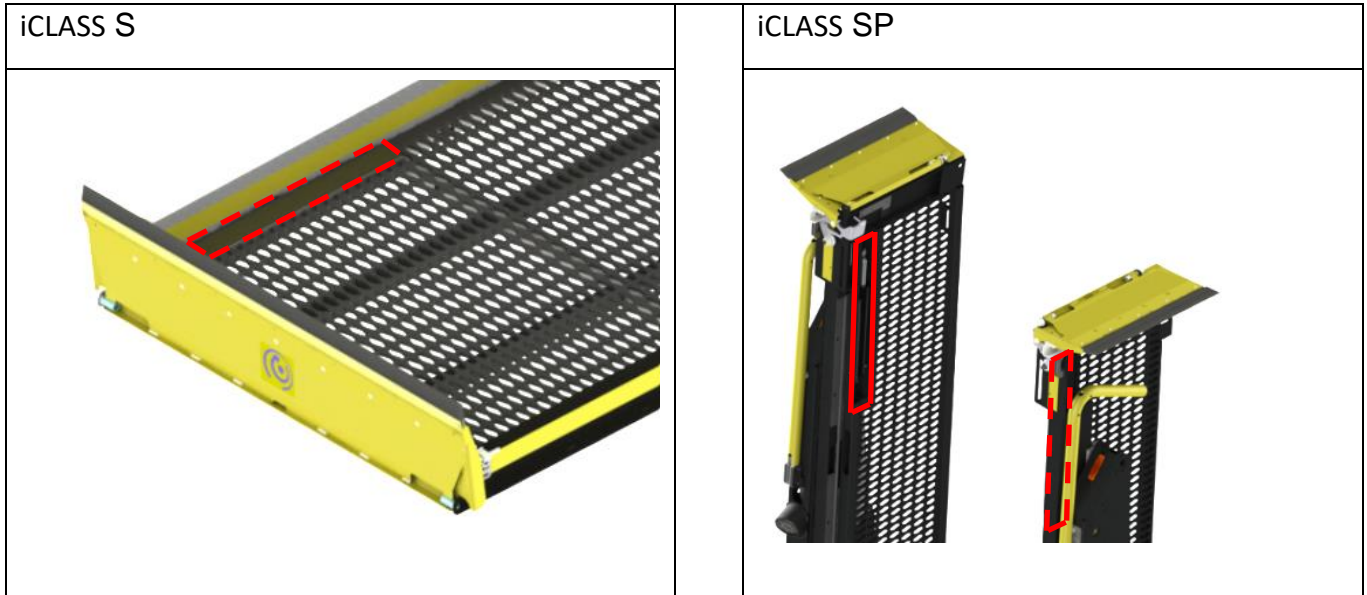

## 12.8 Set lift to work height

**Preparation:** Ensure a clean and uncontaminated work area.

**Tools required:** None  
Disengage the Safety Hook and hold it open when manually deploying lift.

 **DANGER**

Stand clear of deployment area of the lift when disengaging the Safety Hook. After completing the task **ALWAYS** make sure the Safety Hook operates correctly.



Use the manual release valve to lower the lift (A) onto a work station (B), allow all oil pressure to drain from system, outer-barrier will drop (C)

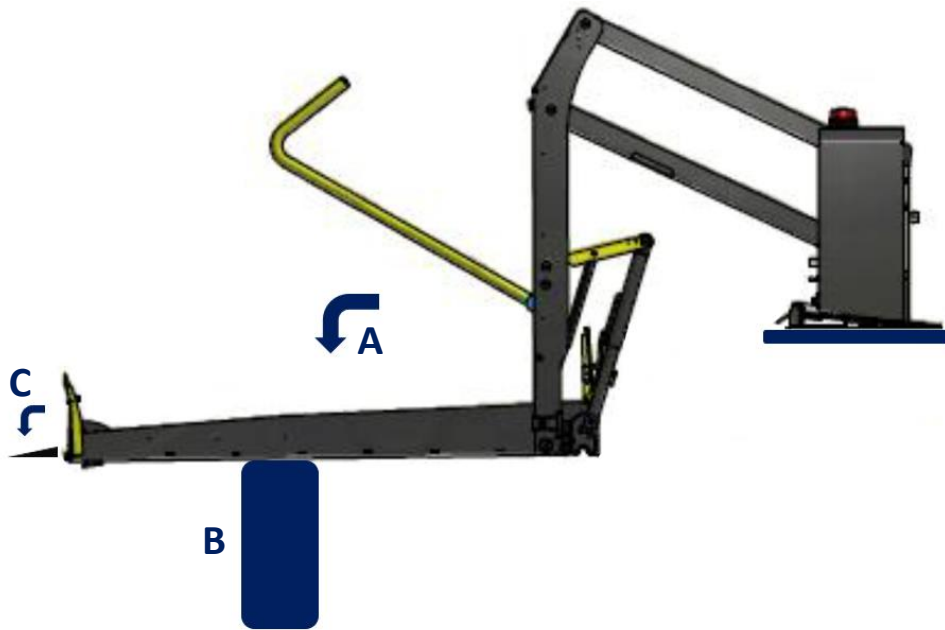

## 12.9 Outer Barrier Cylinder Replacement

**Tools required:** Hex (Allen) Wrenches 6mm, 2x13 and 2x14mm Combination Wrenches, External Circlip Pliers.

Lower the lift onto a work station (See Section 12.8)

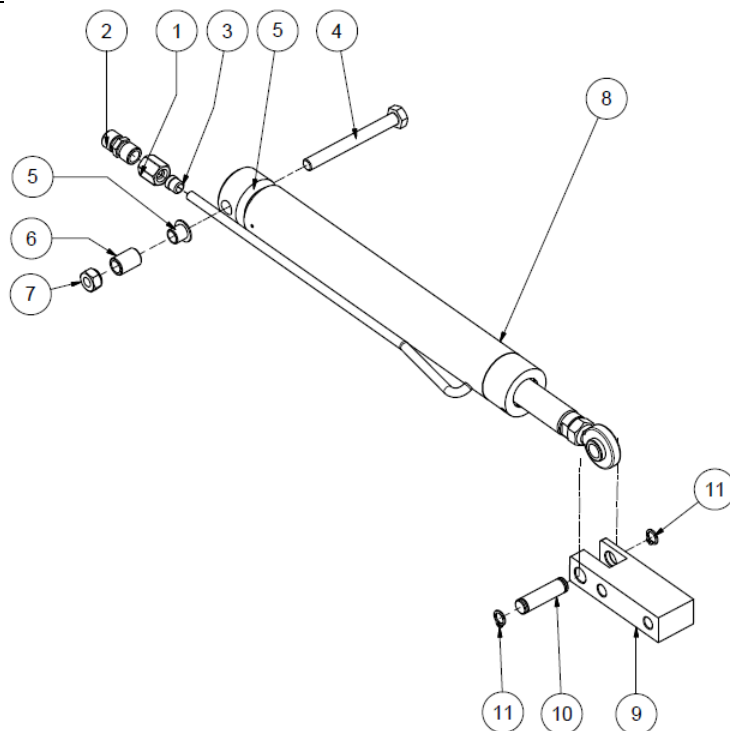

**WARNING**

<ul style="list-style-type: none"> <li>The Outer Barrier Cylinder contains a spring, make sure fingers are clear when releasing fasteners.</li> </ul>
<ul style="list-style-type: none"> <li>Make careful note of position of fasteners and spacers. Take cell phone photos before dismantling, they may be useful for re-assembly!</li> </ul>
<ul style="list-style-type: none"> <li>Outer Barrier end of the cylinder: Remove the linkage block (9) using 6mm Allen Wrench and 13mm Combination Wrench. Remove 2 x M8 Cap screws, nuts and washers. Remove circlip (11) and push out pin (10) to release piston-end of the cylinder.</li> </ul>
<ul style="list-style-type: none"> <li>Be prepared to collect oil then 'crack' the union (using 2x14mm wrenches). (Items 1, 2, 3).</li> </ul>
<ul style="list-style-type: none"> <li>Remove fixings from other end of cylinder, remove M8x75mm Bolt / Washer and Nut (using 2x13mm wrenches). (Items 4, 5, 6, 7). (Remember: take careful note of spacer arrangement!). Move cylinder down and out to side of lift (hose still connected) then release the hydraulic pipe. (Ensure the open hose doesn't get contaminated with dirt/debris).</li> </ul>
<ul style="list-style-type: none"> <li>Replace with new cylinder** and reverse above process to reassemble. Tighten pipe union to 15 Nm (11 lbf.ft).</li> <li>Tighten cylinder end mounting bolt to 21Nm (16 lbf ft).</li> </ul> <p>** It is also possible to replace the oil seal.</p>
<ul style="list-style-type: none"> <li>When reassembled, check and top up oil level. (See section 3.3 for specification).</li> </ul>
<ul style="list-style-type: none"> <li>Charge system, power lift UP. Remove work station then lower lift to ground level.</li> </ul>
<ul style="list-style-type: none"> <li>Operate outer-barrier approximately 20 times to fully bleed out air in system from ground level to 600mm (2'). If necessary, the system can be bled by:</li> <li>Raise onto work station, be prepared to collect oil, crack union then use manual pump to pump oil out of union until air bubbles are no longer seen. Tighten pipe union then re-check the system.</li> </ul>

## 12.10 Service Type D

### 12.10.1 Replace Arm Pivot Pin

Lower the lift onto a workstation (Section 12.8)

Replace the Arm pivot pin and retaining fasteners (circled red, right) (Use 4mm Hex (Allen) wrench, punch and hammer).

On re-assembly use thread locker on the fasteners (NOT the pins!)

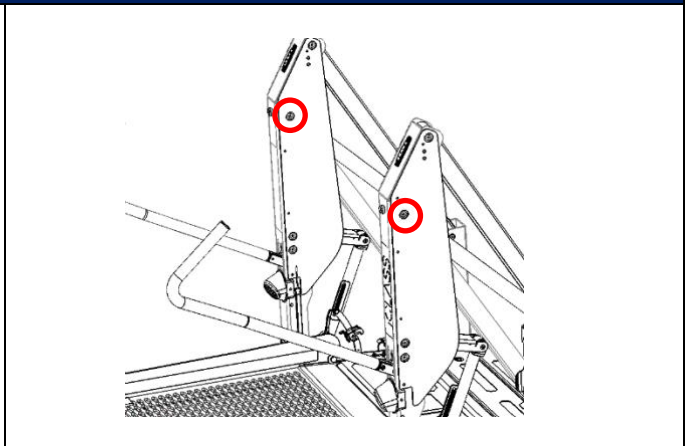

## 12.10.2 Replace Inner Barrier Locks

**Tools required:** Hex (Allen) Wrench 3mm. 8mm Combination Wrench.

Lower the lift onto a work station (See Section 12.8)

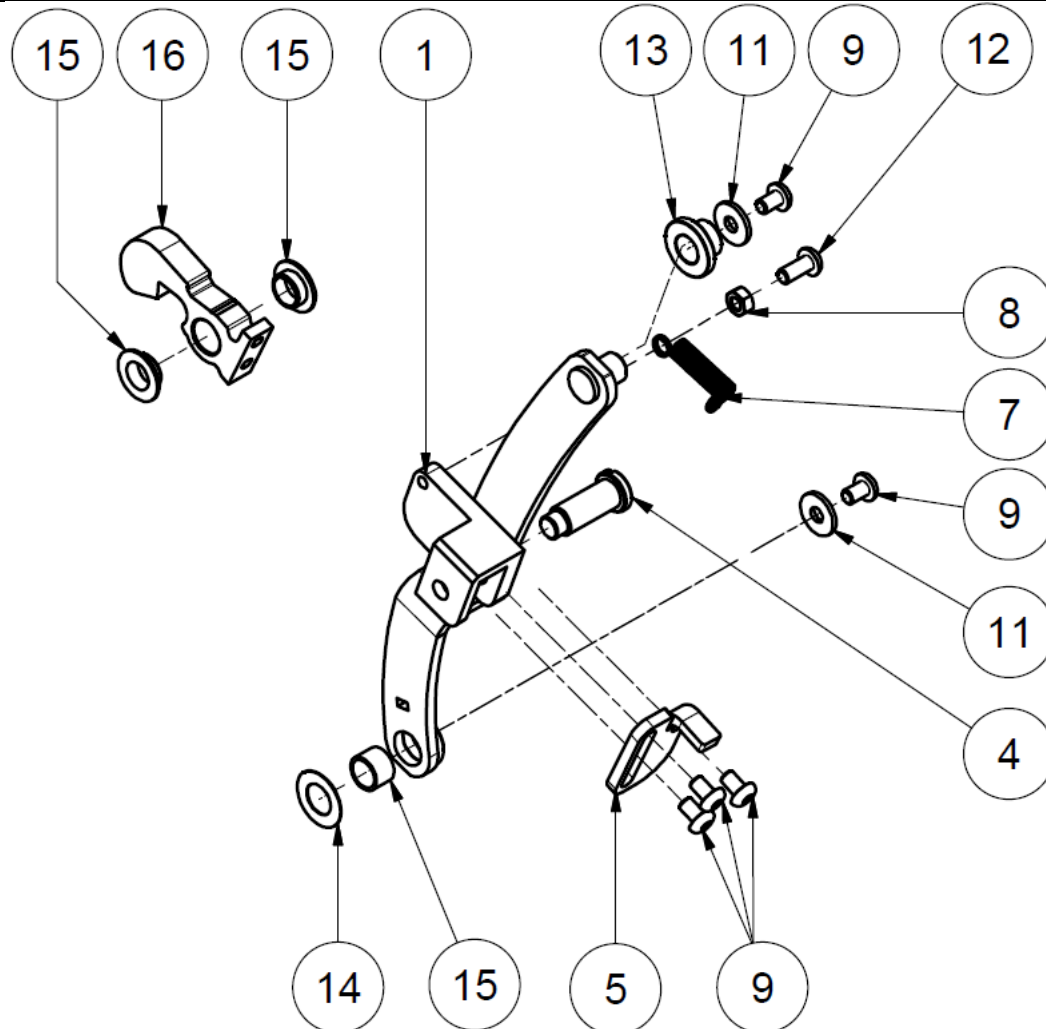

- Replace the assemblies one at a time but replace both locks as a complete set.
- Remove the M5 Hex Dome Screw, washer and spacer from the upper lock. (9, 11, 13)
- Remove the M5 Hex Dome Screw, washers and spacer from the lower lock. (9, 11, 14, 15)
- Remove Lock from barrier (2 x Hex Dome Screw and nylock nuts from inner barrier).
- Assembly is reverse of the above.
- Repeat for the lock on other side of the inner barrier.

### 12.10.3 Oil Check and Change

For translucent tanks, check for dirt / debris and color change. If there are signs of these then change the oil.

Lifts with steel tanks should have the fluid replaced regardless of condition.

To change the oil, deploy the lift to ground level. Supporting the tank, remove the 4 nuts using 10mm wrench.

Empty the oil, clean the tank and re-fit it. Top up with the specified hydraulic oil (see specification section 3.3).

### 12.11 iCLASS Workshop Manual: Arm Cylinder Replacement

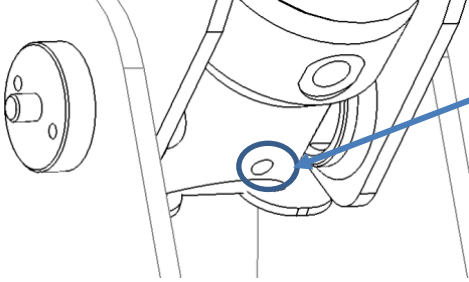
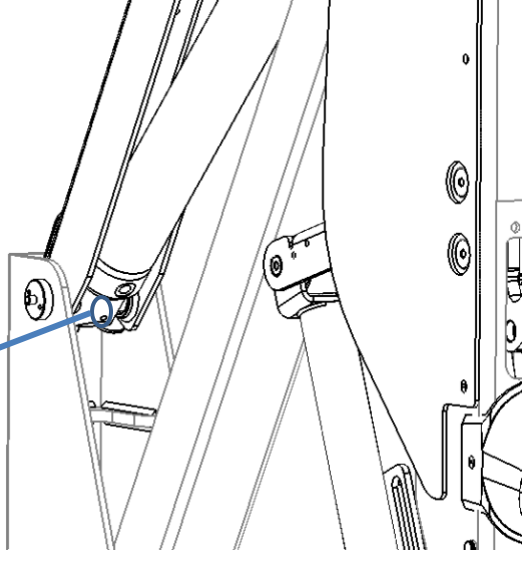
<p><b>Tools required:</b> 15mm diameter drift or punch set, and hammer. Hex (Allen) Wrenches 3, 4, 5mm.</p>	<p>Adjustable Pin Wrench. 13,14mm Combination Wrenches Diagonal cutters</p>
<p>With lift stowed, deploy slightly to allow access to M6 x 20mm grub-screw then fully remove it. (Use 3mm hex (Allen) key).</p> <p>Cut 2 x cable (zip) ties holding hydraulic pipes (not shown).</p> 	
<p>Disengage Safety Hook, Open manual release valve, allow platform to descend to <b>GROUND LEVEL.</b></p>	
<p>Remove Side Covers</p>	

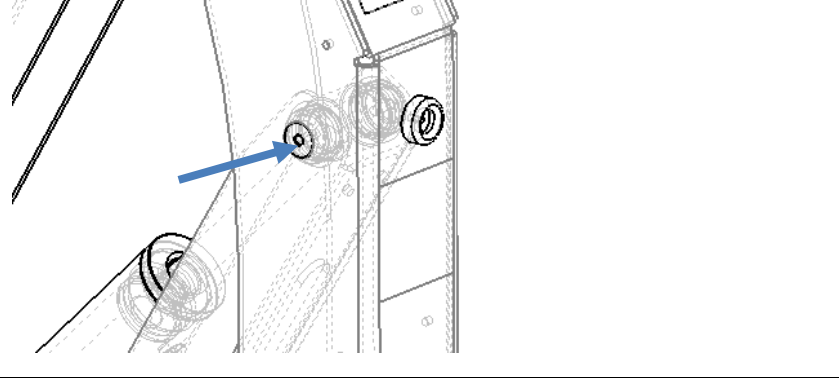
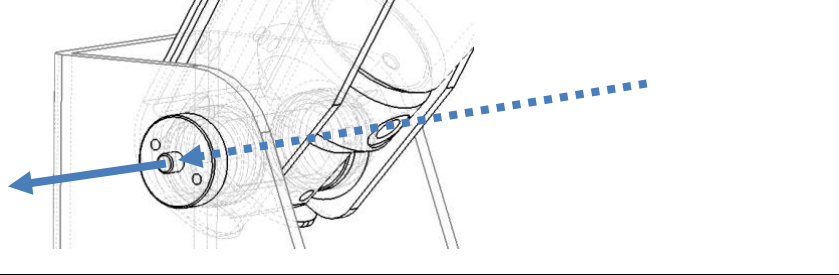
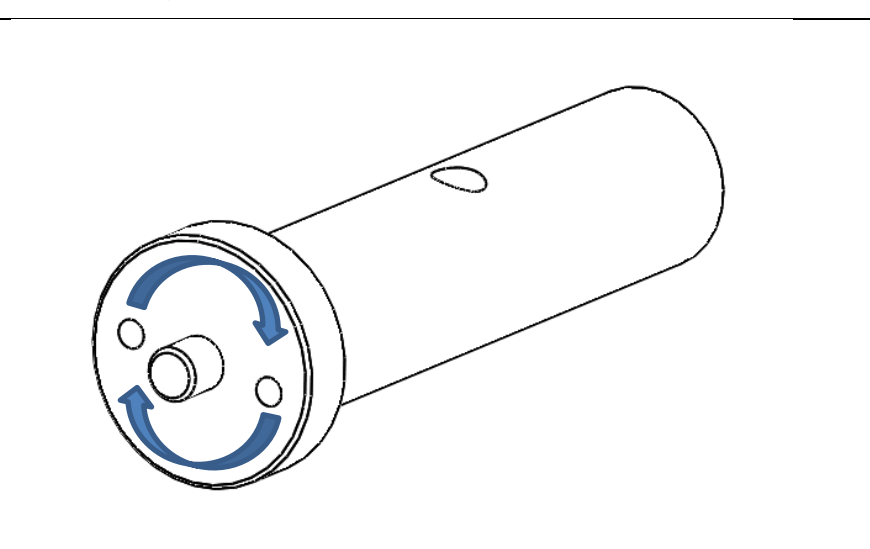
<p>Remove M6 x 10mm dome head hex screw from piston end pin (use 4mm hex (Allen) key).</p>	
<p>Remove pin using drift then remove the drift.</p>	
<p>Remove tower end pin using drift. Remove cylinder but use the drift to support the upper arm hinge on the inside.</p>	
<p>Place absorbent cloth under hydraulic pipe connection, disconnect pipe using 14mm wrench. Protect pipe from dirt ingress.</p>	
<p>Disconnect breather connection using 13mm wrench. Cylinder can now be removed.</p>	
<p style="text-align: center;"><b>Refitting Arm Cylinder:</b></p>	
<p>Reconnect breather hose then fit the cylinder to the top of the arm / tower. Fit pin from the outside then push through gently using a punch to re-align if required.</p>	
<p>Loosely reconnect hydraulic hose.</p>	
<p>Pull piston from cylinder then re-align with hole in vertical outer arm.</p>	
<p>Fit next pin, outer side to inner. Re-fit lower M5 fasteners using thread locker.</p>	
<p>Raise lift to almost stow position, make sure grub screw hole is accessible.</p>	
<p>Use the Pin Wrench to rotate the pin to allow threaded holes to align.</p> <p>Refit grub screw using 3mm hex key and thread locker.</p>	
<p>Lower back to ground level, bleed hydraulic system if required.</p>	
<p>Make sure all fasteners are tightened and perform lift cycles to check.</p>	

## 12.12 iCLASS Workshop Manual: Arm Gas Spring Replacement

### Tools required:

Small External Angled Circlip Pliers  
Small Lever Bar

Pin punch set and Hammer  
Small Locking Pliers

With the lift stowed, remove the lower inner circlip (blue).

With the lever bar push the pin slightly outwards (red).

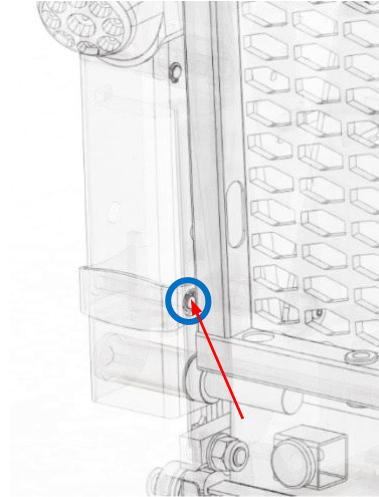

Deploy lift to working height so gas spring is fully decompressed (open)



**WARNING DO NOT ATTEMPT TO REMOVE COMPRESSED GAS SPRING**

Remove Side Covers

Remove lower outer circlip (green).

On the upper mounting pin (orange), remove outer circlip then, using correct size punch, tap the retaining pin inwards. Retrieve the spacer. Release gas spring from upper pin.

Using locking pliers, pull the lower pin outwards (use a hammer to tap gently outwards if required).

The Arm Gas Spring can now be replaced.

Assembly is reverse of the above.

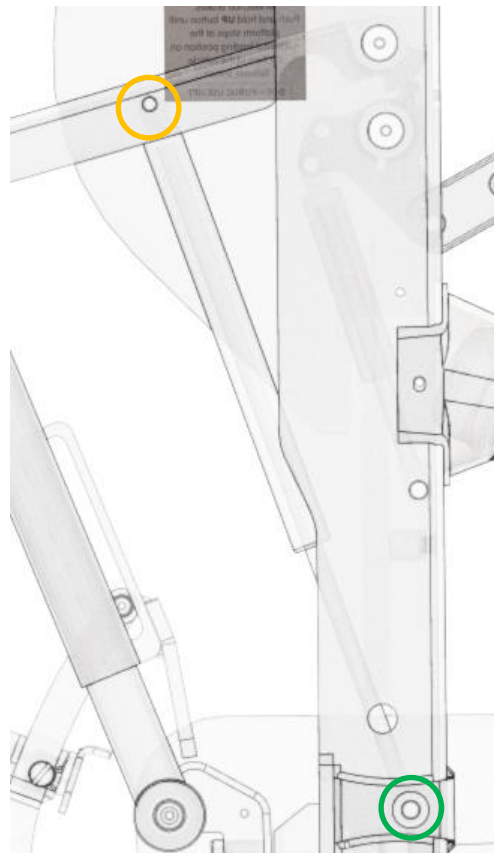

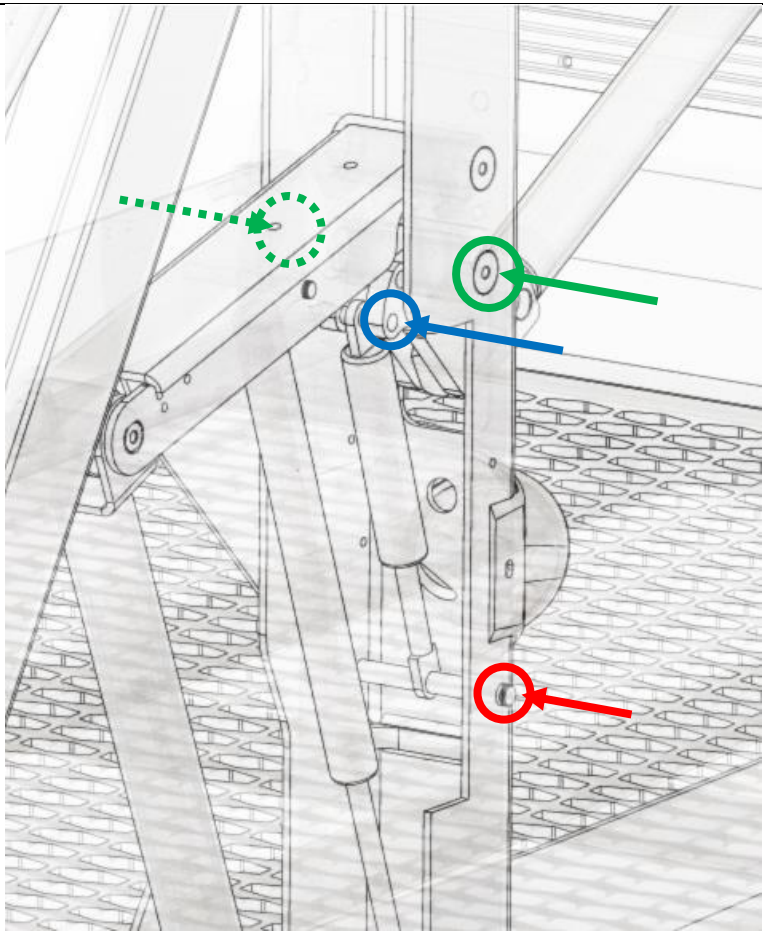

## 12.13 iCLASS Workshop Manual: Safety Handrail Gas Spring Replacement

<b>Tools required:</b> Small External Circlip Pliers Pin punch set and Hammer 4mm Hex (Allen) wrench	
Access is tight, if necessary, remove Arm Gas Spring.	
Deploy lift to working height so gas spring is fully decompressed (open)	
	<b>WARNING DO NOT ATTEMPT TO REMOVE COMPRESSED GAS SPRING</b>
Remove the relevant arm see section 5.4.	
Remove Side Covers	
Remove lower outer circlip (red) then, using correct size punch, tap the retaining pin inwards (Just enough to release spacer). Retrieve the spacer. Release Safety Rail Gas Spring from lower pin.	
Remove upper safety rail mounting pin fasteners (green) M6 x 10mm dome head hex screw and washers (use 4mm hex (Allen) key).	
Push upper safety rail mount inwards, remove sub assembly.	
Release Safety Rail Gas Spring circlips and drift the pin out (blue), noting the position of the spacers.	
Replace the Safety Rail Gas Spring.	
Re-Assembly is reverse of the above.	

## 12.14 iCLASS Workshop Manual: Safety Hook Replacement

### Tools required:

Hex (Allen) Wrench 4mm.

13mm Combination Wrench

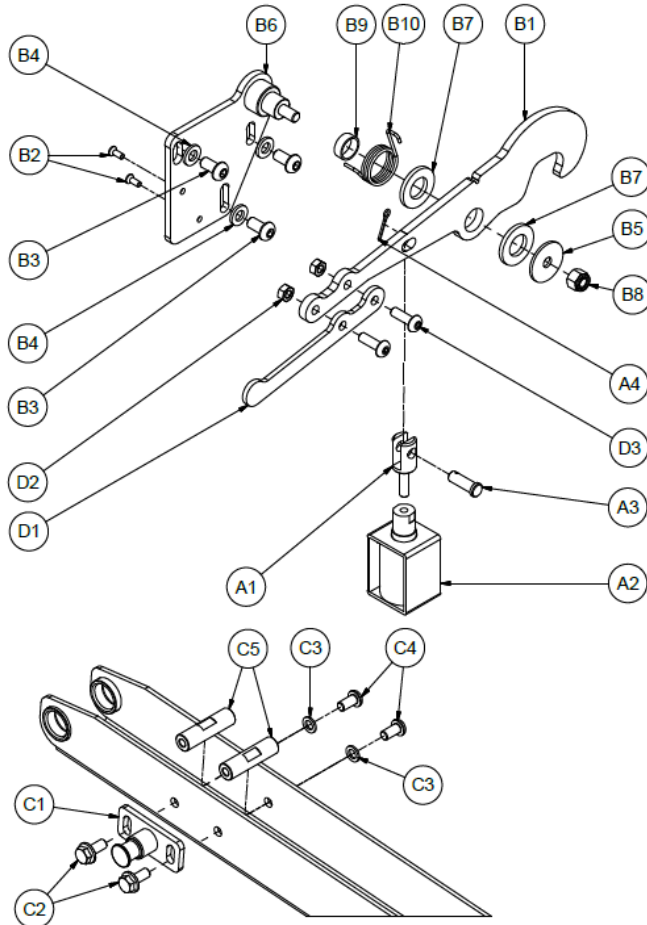

Parts D1, D2, D3 are optional, used when the door opener is fitted.

Deploy lift to ground level.

Release B3 and B4, remove safety hook assembly from the lift tower.

Release C2, remove the Safety Hook Pin from the tower.

Replace Safety Hook Assembly and Safety Hook Pin.

Re-Assembly is reverse of the above.

Cycle the lift a few times to make sure that the hook engages properly with the pin and that the release solenoid functions correctly. Make necessary positional adjustments if required.

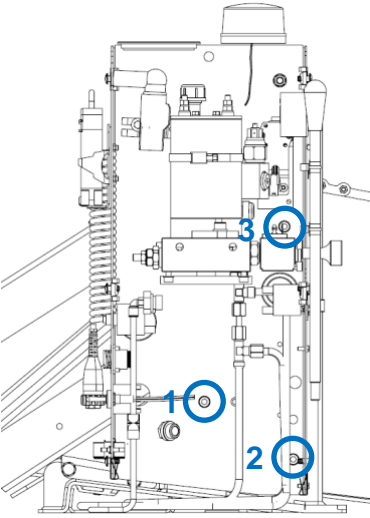

## 12.15 iCLASS Workshop Manual: Power Pack Replacement

<b>Tools required:</b> Flat-blade screwdriver 19mm Combination Wrench Long reach 6mm T-Handle ball end hex (Allen) key	
Release Safety Hook, Open manual release valve, allow platform to descend to <b>GROUND LEVEL</b> .	
Power Off Lift	
	Disconnect Vehicle Battery
Remove Pump Handle Remove Power Pack Cover (Quantity 6 1/4 -turn screws, disconnect display, disconnect warning beacon, disconnect and remove remote control.	
Disconnect vehicle negative (-) Power Pack connection	
Disconnect vehicle positive (+) Power Pack connection (Do not allow red cable to touch any other part of the lift or vehicle body)	
Disconnect all lift loom connections within the powerpack	
<p>The Power Pack is fixed to the lift tower using Qty 3 M8x30mm Hex Cap Screws. The positions are circled in the diagram right (the ECU and oil reservoir have been removed from the image for clarity).</p> <p>It is not necessary to remove oil reservoir to be able to remove the Power Pack.</p> <p>To access these, proceed as follows:</p>	
Above: Figure 12.15.1	
Remove and disconnect the ECU (See Section 12.13)	

Slacken the hydraulic pump assembly fasteners, M10x25mm with 19mm combination wrench. Remove the fastener closest to the arm (green), retrieve star washer, (leave the fastener closest to the tower (red) slack and in place). The hydraulic pump assembly can now rotate.

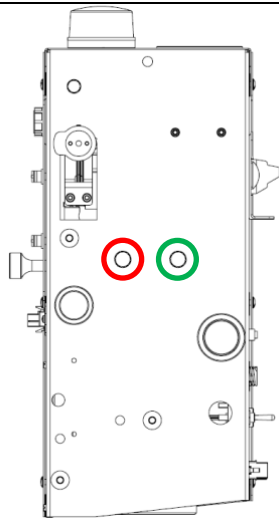

Above: Figure 12.15.2

Remove the Power Pack Fasteners shown in Figure 12.15.1, remove center (1), then bottom (2) then top (3). Use long reach 6mm T-Handle ball end hex (Allen) key. Release the powerpack from the tower assembly (slightly turn the Power Pack to clear the rotary sensor).

Take care to prevent snagging of any cables. Pass them one by one through the aperture in the back of the Power Pack.

Refit then tighten the hydraulic pump assembly fasteners in Figure 12.15.2.

## 12.16 iCLASS Workshop Manual: ECU Removal

**Tools Required:** Flat blade screwdriver.

Make sure the lift is powered OFF then disconnect it from the vehicle battery.



Observe the warnings for ESD in the ECU section of the manual.

Remove the Power Pack cover, turn the ¼-turn screws counter-clockwise with a flat blade screwdriver. Carefully set the cover to one side (there is no need to disconnect the warning beacon light or display wiring) and lean it safely against the lift tower.

The ECU is held in place by 3 screws, see Figure 12.16.1. Remove them.



Above: Figure 12.16.1

Gently pull the ECU out of the Power Pack to be able to unclip the connectors from it. Set the ECU onto a flat, stable surface. Refitting is the reverse of the above.

## 12.17 iCLASS Workshop Manual: ECU Cover Removal

**Tools Required:** Phillips screwdriver.

1. Remove ECU from Power Pack (See section 12.16)
2. Observe ESD precautions
3. Remove the 4 screws. The ECU cover can now be taken off.
4. Reassembly is the reverse of the above

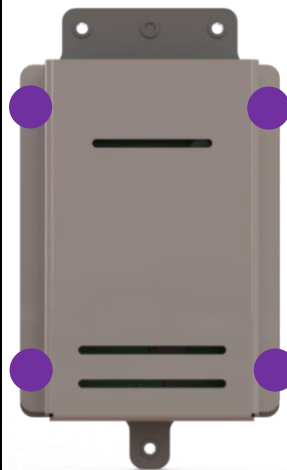

Above: Figure 12.17.1

## 12.18 iCLASS Workshop Manual: Threshold Warning Mat Adjustment

**Tools Required:** Flat blade screwdriver

**Other Equipment:** 5kg weight, 3kg weight

**First Installation:** The Pressure Mat adjustment screw positions are shown **RED CIRCLED** in Figure 12.18.1.

With screws removed apply thread locking compound to the complete length of the thread.

Slacken the screws.

Tighten both **SIDE A** screws 1 turn

Tighten both **SIDE B** screws 1-1/2 turns

Add the 5kg weight to each of the positions shown **1 to 6**.

Make sure the siren / light does not operate when 5kg is added in turn to each position, if it does adjust the screw until it doesn't.

Add the 3kg (8kg total) weight then make adjustments until the light/siren does operate.

\*Note that positions 2 and 4 are over the screw.

**Future Checks:** Unless the Threshold Warning mat has been removed, future adjustments should be very small.

\*if adjustments cannot be made with the 8kg weight, increase to 10kg. If the adjustments are still unsuccessful re-start the adjustment procedure.

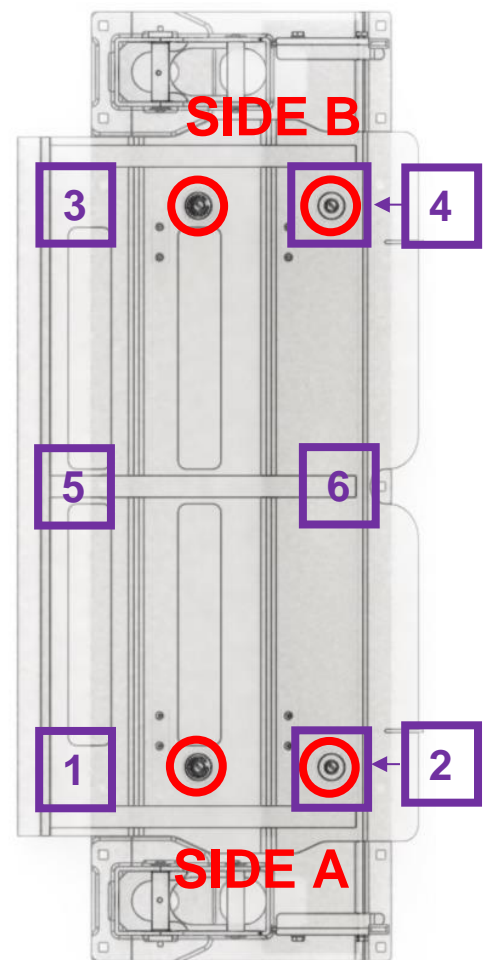

Above: Figure 12.18.1

### Tools required:

Hex (Allen) Wrench 3mm

Diagonal (side) cutters

Pliers

1. Make sure the Power Pack is switched OFF.
2. Using the Hex (Allen) Wrench 3mm, slacken the rotary sensor cam grub-screw.

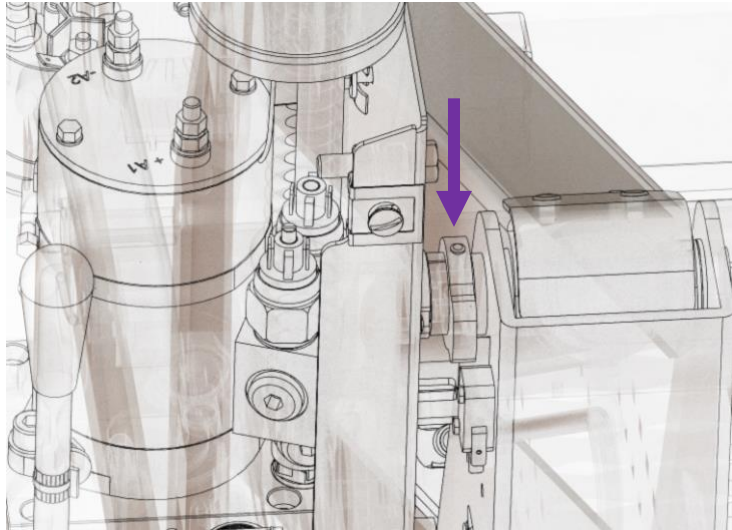

5. Follow the wire from the rotary sensor until a connector to the ECU is found then disconnect it (A)
6. Inside the Power Pack slacken and remove the rotary switch sensor mounting bracket fasteners (B).
7. The sensor / bracket sub assembly can now be removed.
8. Reassembly is the reverse of the above, take care that the sensor locating pins are fitted correctly.

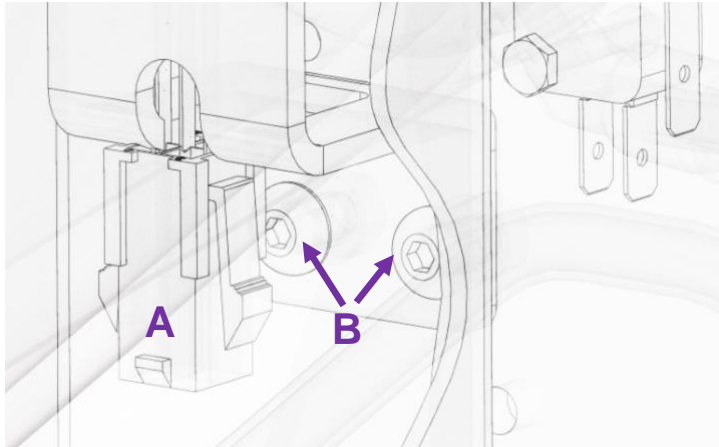

## 12.20 iCLASS Workshop Manual: Platform Levelling

Instructions for adjusting the platform after installation on the vehicle.

Adjusting the inclination of the platform is a fundamental operation for the correct operation of the lift. Some aspects, such as the model of the vehicle, the housing area of the lift, both side and rear of the vehicle, the ownership of the vehicle, affect the correct inclination of the platform pre-calibrated at the factory. It is therefore necessary to carry out these operations after having mounted the lift on the vehicle.

Move the platform and bring it to a position halfway between the ground and the loading surface to facilitate adjustments.

Using a size 6 Allen wrench, act on the anchors on both sides of the platform to adjust its inclination.

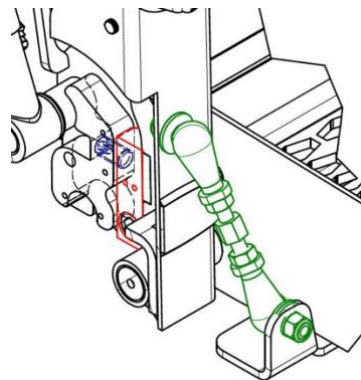

Turn the dowels clockwise to raise the footplate tip and unscrew them to lower it.

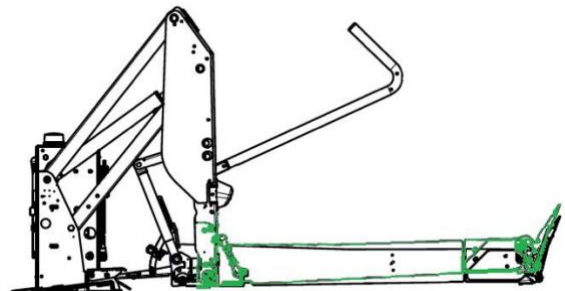



Bring the inclination of the platform to **ZERO DEGREES** using a metric level to be placed on the platform.



**IMPORTANT: THE ADJUSTMENT OF THE GRAINS MUST BE PERFORMED SIMULTANEOUSLY ON BOTH SIDES OF THE PLATFORM AND UNIFORMLY TO ENSURE THE CORRECT LEVELLING OF THE PLATFORM.**

For the SP model, it is necessary to check the correct registration of the joints as per instruction.

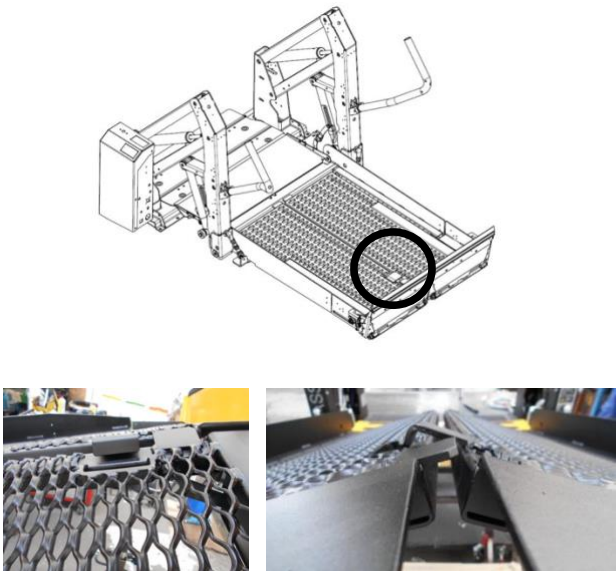
If the strikers are not aligned to closing and do not allow the platform to close correctly, the **CENTRAL SCREW** of the joint must be adjusted as follows:

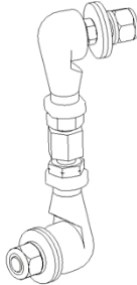
<p>From a closed platform, command opening to bring the two halves of the platform closer. Loosen the joint nuts first and then the other in order to loosen the vice on the central screw.</p>	 <p>The diagram shows a top-down view of the platform's joint mechanism with a black circle highlighting the central screw area. Below the diagram are two photographs: the left one shows a close-up of the joint's mesh structure, and the right one shows the platform's edge and joint assembly.</p>
<p>To adjust the height of the half-platform, unscrew the <b>CENTRAL SCREW</b> clockwise or anti-clockwise. The half-platform will rise or lower, according to the data revolutions.</p>	 <p>A close-up photograph of the central screw adjustment mechanism. A metal handle is attached to the screw. In the background, a label indicates a maximum load of 1000 kg and a safety warning symbol (SWL 1).</p>
<p><b>NOTE:</b> Each joint moves the adjacent half-platform. The manoeuvre must be performed on both joints to obtain a correct platform set-up.</p> <p><b>ONCE VERIFYING THAT THE STRIKERS OF THE TWO HALF-PLATFORMS DO NOT TOUCH, TIGHTEN THE NUTS NEAR THE JOINTS.</b></p>	
<p><b>ATTENTION:</b> The rotation of the screw depends on the joint. If it rotates right, it is the right joint. If it rotates left, it is the left joint.</p>	 <p>A technical line drawing of the central screw assembly, showing the handle, the screw, and the nuts at both ends.</p>



## 12.21 iCLASS Workshop Manual: Outer Barrier Check and Adjustment

(iCLASS S and SP only)



### WARNING

These instructions are for the exclusive use of appropriately trained technical personnel.

**Tools Required:** Small flat blade screwdriver

**Other Equipment:** 9.5kg (21lbs) weight, 70kg (154lbs) weight

Deploy the lift to ground level and the outer barrier opens.

Place the 9.5kg (21lbs) weight onto position 1.

Place the 70kg weight centred on the platform.

If the lift stops and the alarm sounds, the check is successful.

Repeat for position 2.

If either or both checks are unsuccessful follow the procedure in Section 7.5.

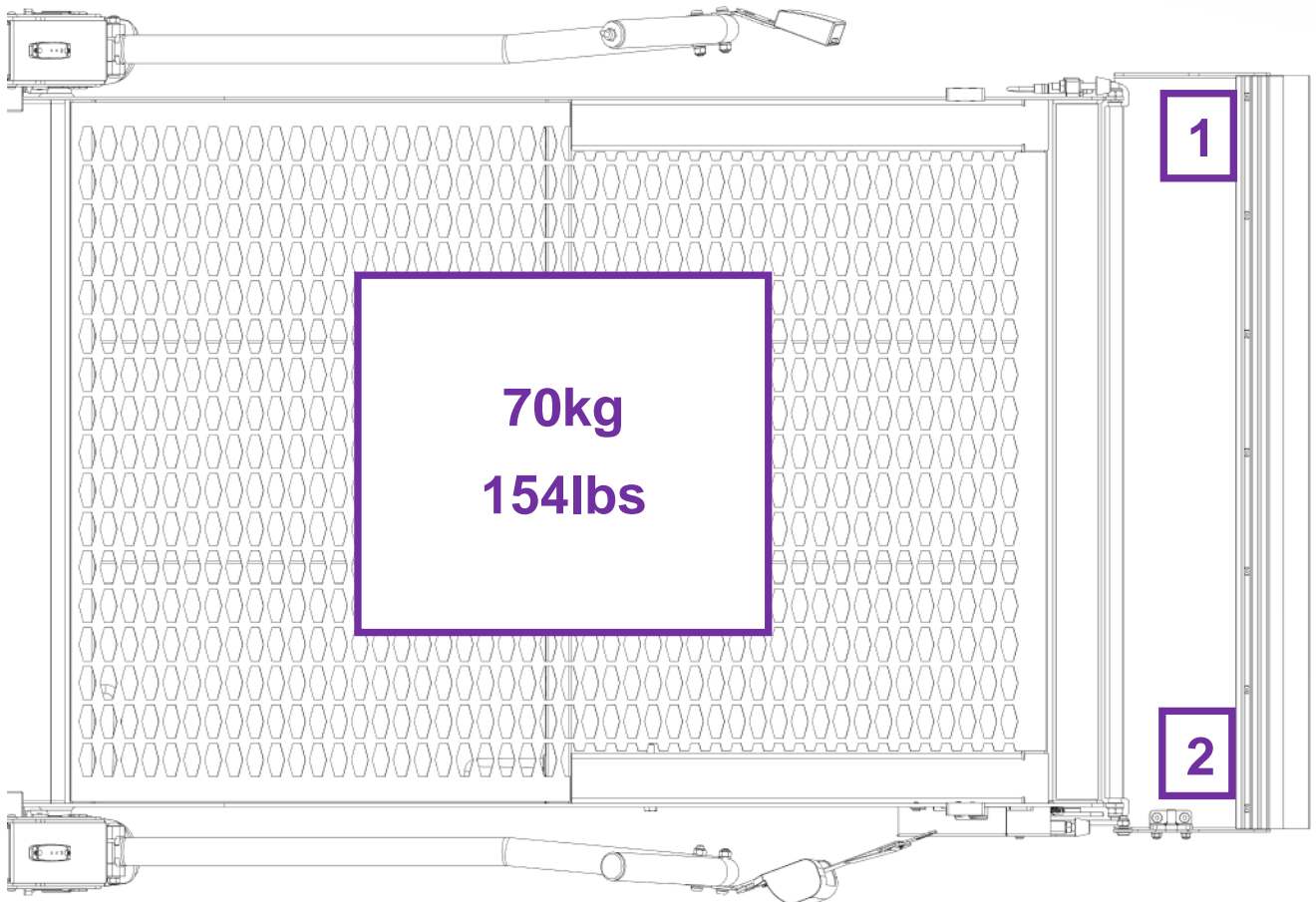

Above: Figure 12.21.1

## 12.22 iCLASS Workshop Manual: Platform Stow Check and Adjustment



### WARNING

These instructions are for the exclusive use of appropriately trained technical personnel.

**Tools Required:** Small flat blade screwdriver, inclinometer or tape measure.

**Other Equipment:** 22.7(50lbs) weight

Deploy the lift to ground level. Load the 22.7kg weight onto the platform, centred left to right and the centre of the weight 250mm (10") from the outer barrier. Place the inclinometer next to the weight.

Press "UP" on the controls until the lift reaches vehicle floor level.

"ZERO" the inclinometer. (or measure the height of the platform under the outer barrier to the floor).

Press the "STOW" button.

If the lift stops and, the alarm sounds and the lift angle doesn't increase by 2.5-3 degrees, the check is successful.

If the check is unsuccessful follow the procedure in Section 7.5.



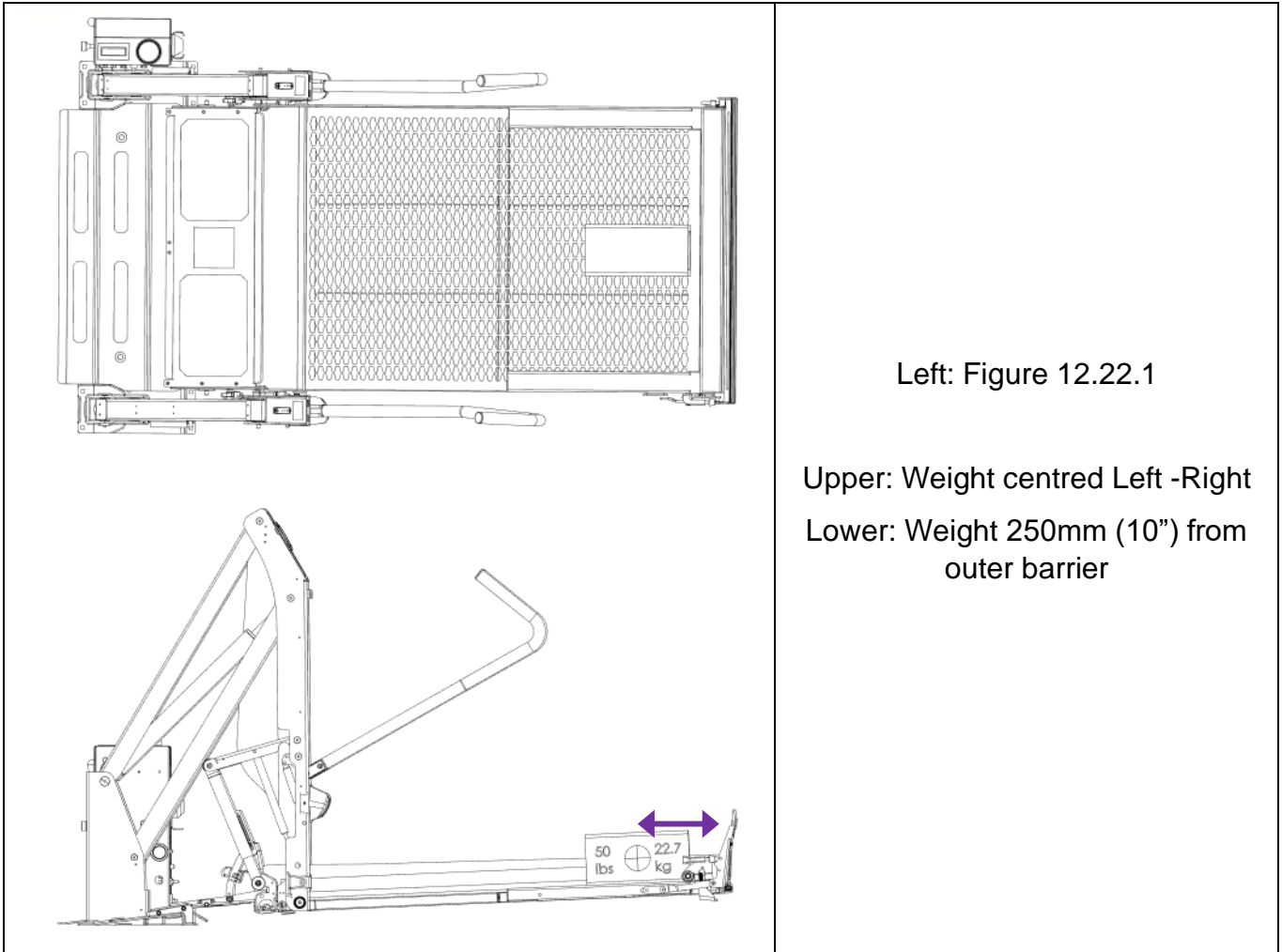

Left: Figure 12.22.1

Upper: Weight centred Left -Right  
 Lower: Weight 250mm (10") from  
 outer barrier

## 12.23 iCLASS Workshop Manual: Inner Barrier Check and Adjustment

	<b>WARNING</b>
These instructions are for the exclusive use of appropriately trained technical personnel.	
<b>Tools Required:</b> See Section 12.18.	
<b>Other Equipment:</b> 9.5kg (21lbs) weight.	
Deploy the lift to floor level and the outer barrier opens.	
Place the 9.5kg (21lbs) weight onto position 1.	
Press the "DOWN" button on the controller.	
If the lift stops and the alarm sounds, the check is successful.	
Repeat for position 2.	
If either or both checks are unsuccessful the Threshold Warning Mat requires adjustment, follow the procedure in Section 12.18.	

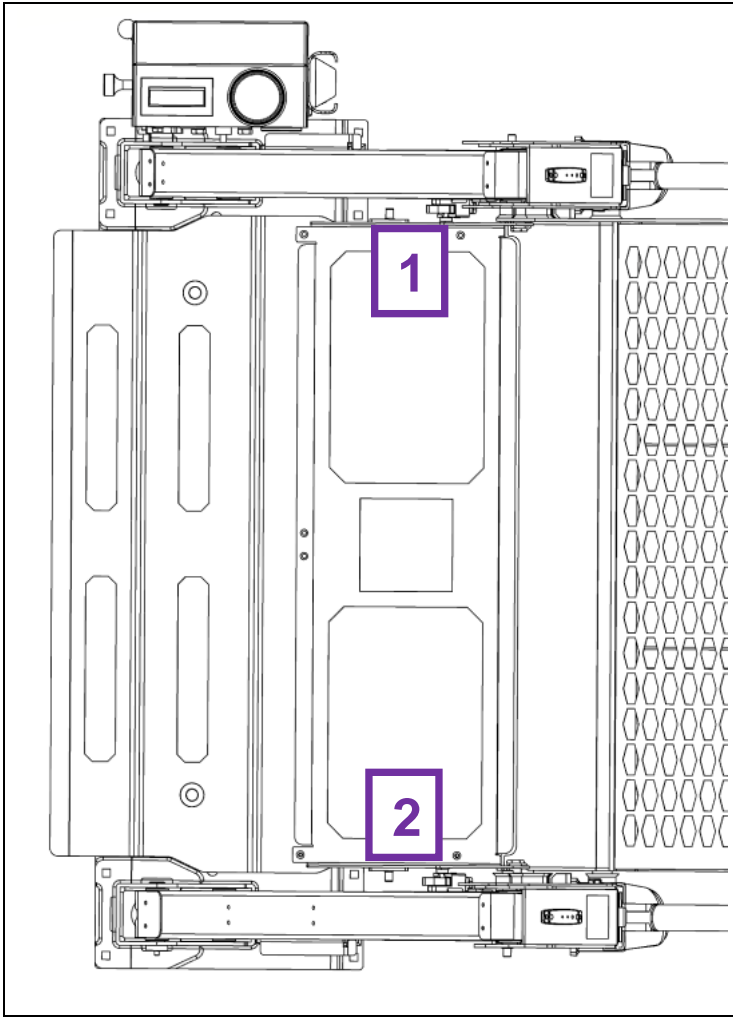

Left: Figure 12.23.1

## 12.24 iCLASS Workshop Manual: Handrail Safety Belt Installation



### WARNING

These instructions are for the exclusive use of appropriately trained technical personnel.

#### Tools Required:

Tools Required: 3, 5mm Hex (Allen) wrenches, 13mm Combination Wrench, 2 x 18mm combination wrenches, side cutters (optional).

**Other Equipment:** Handrail Safety Belt Kit, Zip-ties (optional). Mobility Networks Smart Lift App.

**Refer to the exploded diagrams in Section 18, drawing Tav 19.**

**IMPORTANT NOTE:** The **Safety Belt Buckle** is fitted to the same side as the **Power Pack**. These instructions show the layout with the Power Pack fitted to the **RIGHT-HAND** side of the lift.

If the Power Pack is fitted to the **LEFT-HAND** side of the lift then fit the Buckle and wiring harness to the **LEFT** handrail.

- DEPLOY and lower lift to working height
- On the handle flange, remove cover plate (Quantity 2 M5 x 10mm dome hex screws) (with 3mm Hex (Allen) key, see Figures 12.24.1 and 12.24.2).
- Fit the grommets to the handrail and the brackets.

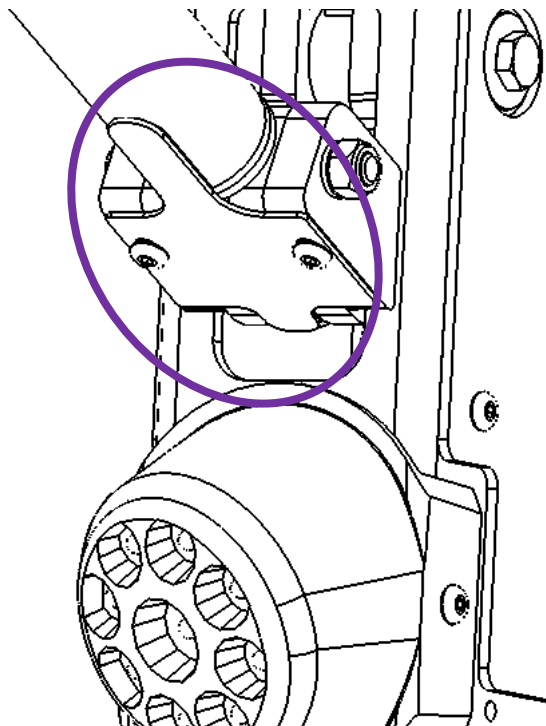

Above: Figure 12.24.1 cover plate in situ

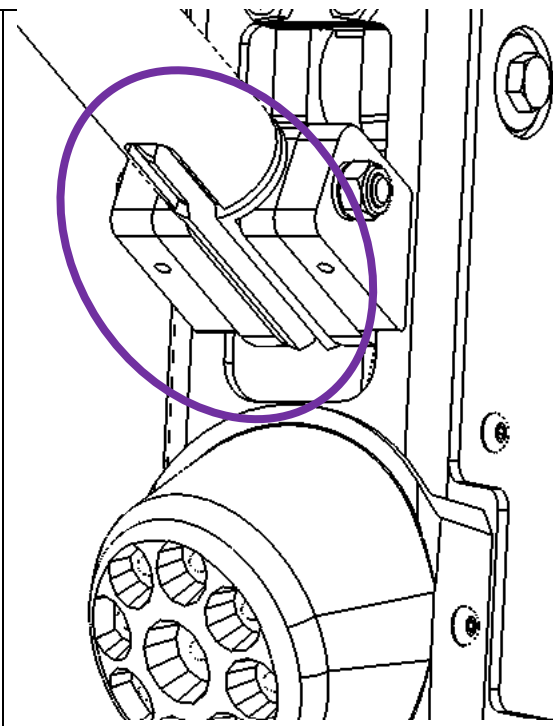

Above: Figure 12.24.2 cover plate removed

- Thread the Safety Belt Wiring Harness into the hole on the Handrail, see Figure 12.24.3. until the plug exits at the handle flange.
- Leave the connector for the buckle outside.

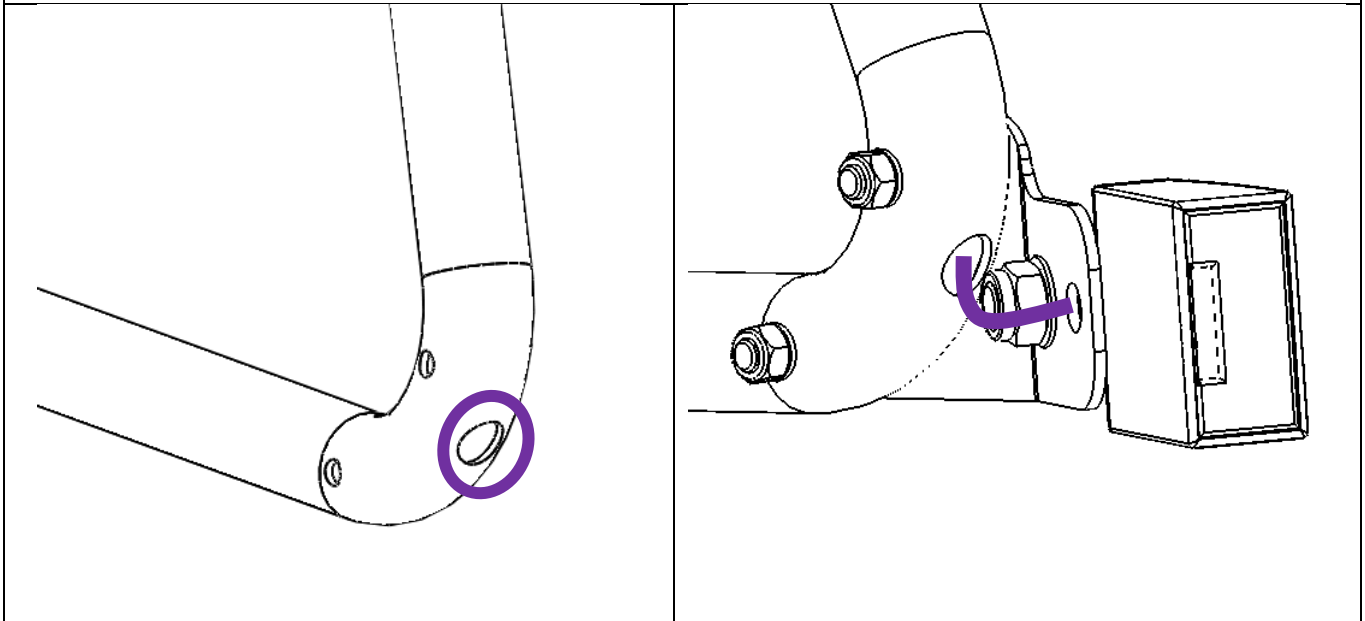

Above Figure 12.24.3 Handrail Cable Entry	Above Figure 12.24.4 Shown with Buckle fitted
<ul style="list-style-type: none"> <li>• Fit the brackets to the arms with the M8 fasteners (from Outboard in the order Screw, Washer, Fitting Plate, Handrail, Washer, Nut).</li> </ul>	
<ul style="list-style-type: none"> <li>• Fit the buckle to the bracket with the 7/16"NUF fasteners (from Outboard in the order Screw, Buckle (Retractor*), Fitting Plate, Washer, Nut).</li> <li>• See Figure 12.24.4 showing right-hand side bracket / buckle assembly.</li> </ul>	
<ul style="list-style-type: none"> <li>• Connect the buckle to the Safety Belt Wiring Harness. Push the connector and slack cable into the handrail, Figure 12.24.4.</li> </ul>	
<ul style="list-style-type: none"> <li>• At the other end of the handrail, thread the other end of the wiring harness into the arm. Make sure the path for the cable is clear and that it won't snag on any part of the knuckle mechanism.</li> <li>• Connect it to the plug in the arm.</li> </ul>	
<ul style="list-style-type: none"> <li>• Reversing the earlier step, on the handle flange, replace the cover plate making sure the cable doesn't get trapped.</li> </ul>	
<ul style="list-style-type: none"> <li>• Taking care to make sure the new cable and connections don't get trapped, STOW the lift.</li> </ul>	
<ul style="list-style-type: none"> <li>• DEPLOY and lower the lift to working height then, if necessary, carefully position and tighten zip-ties to tidy any excess cables inside the arm.</li> </ul>	
<ul style="list-style-type: none"> <li>• On the other handle, attach the retractor to the handle using the same method as the buckle*.</li> </ul>	
<ul style="list-style-type: none"> <li>• Tighten all fasteners to the required torque. Fit Nut and Bolt Caps to the 7/16 fasteners.</li> </ul>	
<ul style="list-style-type: none"> <li>• Using the Mobility Networks Smart Lift APP: go to the Installer page.</li> <li>• On 'Belt Interlock Status' read then change the status from 0 to 1.</li> <li>• Reboot the lift.</li> </ul>	

Great care needs to be taken during the cleaning process, all cleaning should be carried out by hand using a gentle cloth or sponge soaked in non-aggressive detergent and then rinsed with a cloth dampened with water. Ensure all moving parts are re-lubricated where necessary.



**WARNING**

**DO NOT USE AGGRESSIVE DETERGENTS**

**DO NOT USE PRESSURE WASHERS OR HOT WATER JET CLEANERS**

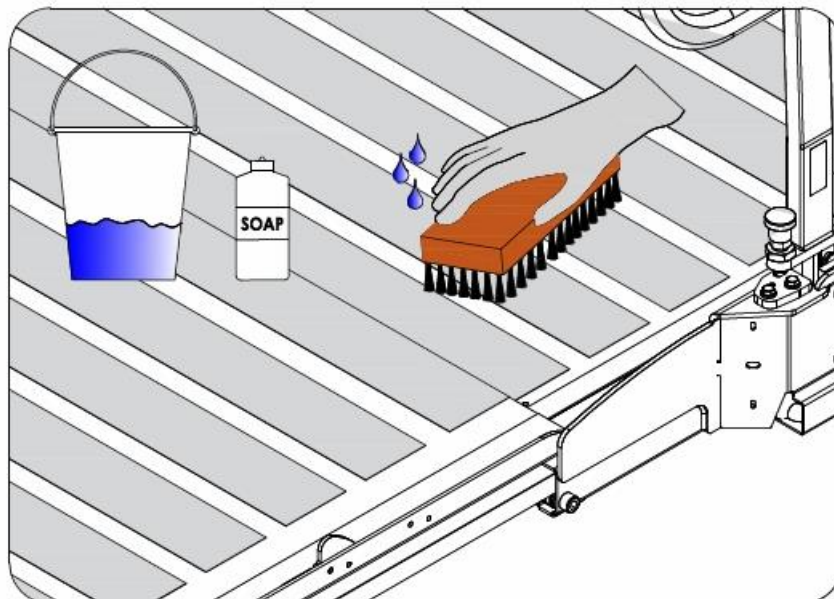
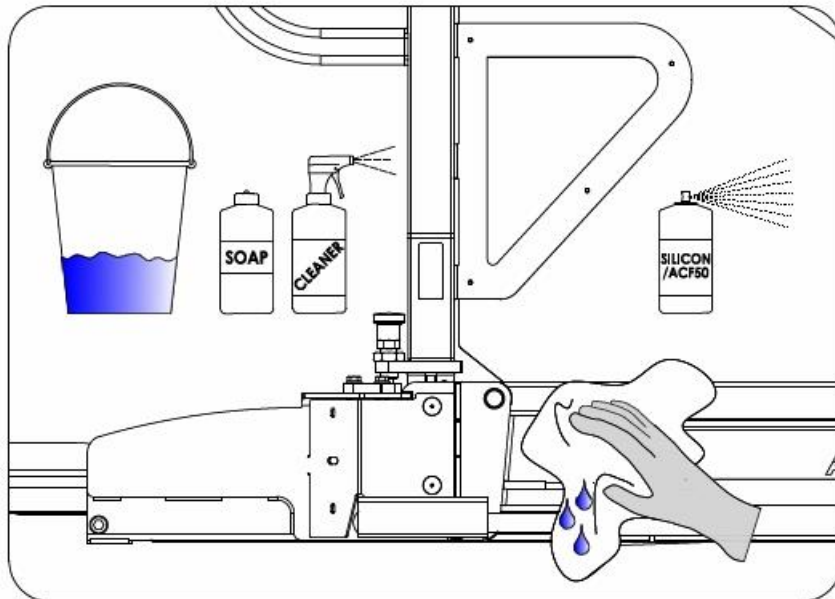

**After cleaning, check and re-lubricate parts per Section 14**

See Figure 14.1 for lubrication, grease all pins, use ACF-50 for all other parts.

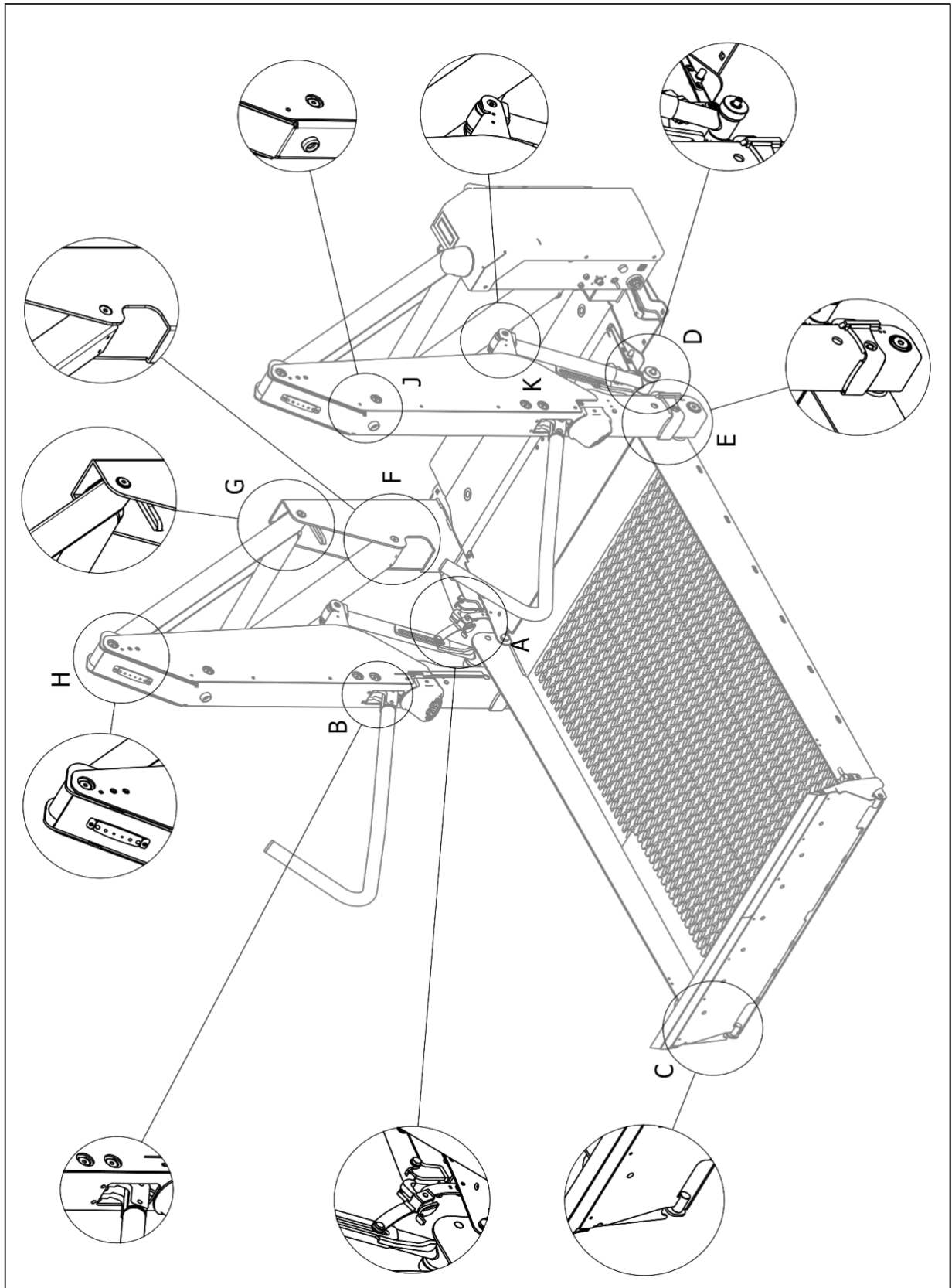

Figure 14.1 Lubrication points

## 15.1 Inspection and Service Data Sheet

<b>Inspection / Service 1</b> Date Driver/ Operator Name Signature	<b>Inspection / Service 2</b> Date Driver/ Operator Name Signature	<b>Inspection / Service 3</b> Date Driver/ Operator Name Signature
<b>Inspection / Service 4</b> Date Driver/ Operator Name Signature	<b>Inspection / Service 5</b> Date Driver/ Operator Name Signature	<b>Inspection / Service 6</b> Date Driver/ Operator Name Signature
<b>Inspection / Service 7</b> Date Driver/ Operator Name Signature	<b>Inspection / Service 8</b> Date Driver/ Operator Name Signature	<b>Inspection / Service 9</b> Date Driver/ Operator Name Signature
<b>Inspection / Service 10</b> Date Driver/ Operator Name Signature	<b>Inspection / Service 11</b> Date Driver/ Operator Name Signature	<b>Inspection / Service 12</b> Date Driver/ Operator Name Signature

**This page MUST be produced when claiming warranty repairs**



	Control Handset		Electrical Issue
	Hydraulic Oil or Component		ECU Related

Problem	Cause	Solution
Lift not working / slow	Lower power available (less than 9 volts)	Charge battery, start engine, swap battery
Lift not working / slow	Low oil level in pump	Lower lift to ground, fill tank to within 20mm from top
Lift not working	Main Fuse / Circuit breaker blown or tripped	Reset or replace (should be location next to power source)
Lift not working / erratic	Control handset faulty	Check wires, pins, plugs replace handset if necessary

Power ON light not working	Main Fuse / Circuit breaker blown or tripped	Reset or replace (should be location next to power source)
	Isolating circuit not OPEN: Main switch, door, handbrake, suspension, etc (vehicle motion stops lift working)	STOP vehicle, handbrake ON, lift Door FULLY Open, switch ON
	Platform not in STOWED position	Press STOW button to stow platform correctly (or pump lift UP with handpump)
	Power ON LED broken	Replace LED
	Control handset faulty	Replace handset

Platform does not deploy	Safety lock not unlocking (does hook lift when press DEPLOY?)	Manually override safety hook (to test)
	Control handset connected incorrectly	Check handset plug & pins are mated correctly
	Control handset faulty	Replace handset
	Lowering valve solenoid electrical circuit OPEN	Check and close circuit
	Lowering valve/solenoid broken (or blocked)	Replace (or remove and clean) lowering valve
	Deploy gas-springs not working	Test gas-springs, replace if not working to full power
	Closed position incorrectly programmed	Reprogram CLOSED position on ECU

Platform TWISTING when Deployed	Restriction in hydraulic cylinder / system?	Check for pinched hoses, replace if necessary
	Restriction in hydraulic cylinder / system?	Hydraulic cylinder restrictor blocked
	Damaged lifting hydraulic cylinder seals	strip and replace cylinder seals (or swap cylinder)



Lift FALLING out from vertical Stow and NOT unfolding	Arm gas-spring lost power	Replace if required
	Anti-rattle plate too tight (or wheel)	Adjust plate angle

Platform does not lower to Ground	Threshold mat tripping	Ensure mat/plate is clear, and springs have returned UP
	Control handset connected incorrectly	Check handset plug & pins are mated correctly
	Control handset faulty	Replace handset
	Lowering valve/solenoid broken (or blocked)	Replace (or remove and clean) lowering valve
	ECU issue	Reprogram ECU (replace as last resort)
	Mechanical system dry / dirty	Clean and lubricate moving parts
	Lifting cylinder damaged (or corroded)	Check and replace if necessary

Platform does not STOP at correct vehicle floor height (when operating Up or Down?)	Loading level incorrectly programmed	Reprogram Floor-height level
	Rotary sensor issue	Adjust, re-set or replace
	Control handset connected incorrectly	Check handset plug & pins are mated correctly
	Control handset faulty	Replace handset

Platform does not lift UP from Ground (is main pump motor working or not?)	Safety belt not correctly used	Ensure belt correctly plugged to opposite handrail
	Motor working but no pressure: Manual override valve OPEN	Close valve
	Lowering valve solenoid electrical circuit OPEN	Check and close circuit
	Lowering valve/solenoid broken (or blocked)	Replace (or remove and clean) lowering valve
	Outer barrier sensor signal incorrect	Adjust sensor position, replace if necessary
	Hydraulic pressure switch fault	Adjust pressure switch (replace if cannot adjust)
	Control handset faulty	Replace handset
	Hydraulic Powerpack fault	Replace whole powerpack unit
	ECU issue	Reprogram ECU (replace as last resort)

Platform does not STOW (fully up and vertical)	Safety belt not correctly used	Ensure belt UNPLUGGED to allow lift to power UP into Stow
	Threshold mat tripping	Ensure mat/plate is clear, and springs have returned UP
	Hydraulic pressure switch fault	Adjust pressure switch (replace if cannot adjust)
	Lowering valve/solenoid broken (or blocked)	Replace (or remove and clean) lowering valve
	ECU issue (correct angle not programmed)	Reprogram ECU (replace as last resort)
	Control handset faulty	Replace handset
	Hydraulic Powerpack fault	Replace whole powerpack unit
	Mechanical parts locked/jammed	Trace broken/stuck linkage. Replace, clean, lubricate

Auxiliary handpump not working	Air in system	To bleed air out: open manual override tap, pump 10 times, close and retry
	Handpump broken (locked or pumping loose)	Replace handpump
	Manual override valve OPEN	Close valve

Outer barrier not lowering or lifting correctly (or locking in vertical position)	Cylinder not fully retracting	Mechanism sticking, check fastenings and lubricate
	Cylinder losing power	Worn internal spring, replace cylinder
	Air in cylinder	Operate up/down 15 times to bleed, crack hose if possible
	Safety hook not engaging	Adjust hook & pin to suit, lubricate
	Low Pressure switch not working	Adjust pressure switch to suit
	Outer barrier sensor signals incorrect	Adjust sensor position, replace if necessary

Inner barrier not lifting UP	Arm linkage not moving correctly	Check, clean adjust, lubricate
	Gas-strut lost pressure	Swap out for new
	Arm gas-spring lost power	Replace if required

Inner barrier not lowering	locking hooks stuck	Adjust hook and/or pins to suit. If worn replace parts
	Arm linkage not triggering hooks	Adjust to suit or replace striker/hook components

Inner barrier not locking	locking hooks not engaging	Springs not effective, adjust or replace
	locking hooks not engaging	Adjust hook and/or pins to suit. If worn replace parts
	Arm linkage not moving correctly	Check, clean adjust, lubricate

Handrail not deploying (or sticking)	Adjustment bolts incorrect position	Adjust to suit
	Handrail gas-strut worn / lost pressure	Swap out for new
	Internal cam worn	Adjust or replace cam / internal linkage parts

Manual tap breaking	Turning too far OPEN or CLOSED	Replace handle or Down valve if required
---------------------	--------------------------------	--

Threshold warning mat constantly tripping or NOT working	Sensor strips compressed	Check anti-crush blocks are set correctly
	Threshold mat damaged	Adjust or replace as necessary
	Cable worn, cut, fault at connector	Check cables, replace sensor if required
	Red LED not working	Check component and cables, replace if required
	Warning buzzer not working	Check component and cables, replace if required
	ECU issue	Reprogram ECU (replace as last resort)

Lift Pump issues: Noisy, Slow, cannot produce pressure	Lower power available (less than 10.5 volts)	Charge battery, start engine, swap battery
	Low oil level in pump	Lower lift to ground, fill tank to within 20mm from top
	Contaminated oil (swarf, grit, dirt, old oil, etc)	Check oil, flush system and add new oil
	Air in system	Operate system approx. 20 times to bleed
	Worn DC motor	Replace motor or pump
	Worn hydraulic pump	Replace powerpack
	ECU issue	Reprogram ECU (replace as last resort)

Platform not horizontal	Not adjusted correctly from installation	Adjust angle up or down (outer barrier should land first)
	Platform / parts damaged	assess and replace where required

LEDs not on	Faulty wires	Check wires repair or replace
	Faulty LEDs	Check repair or replace
	ECU board blown	Replace ECU

## 16.1 Switch Locations

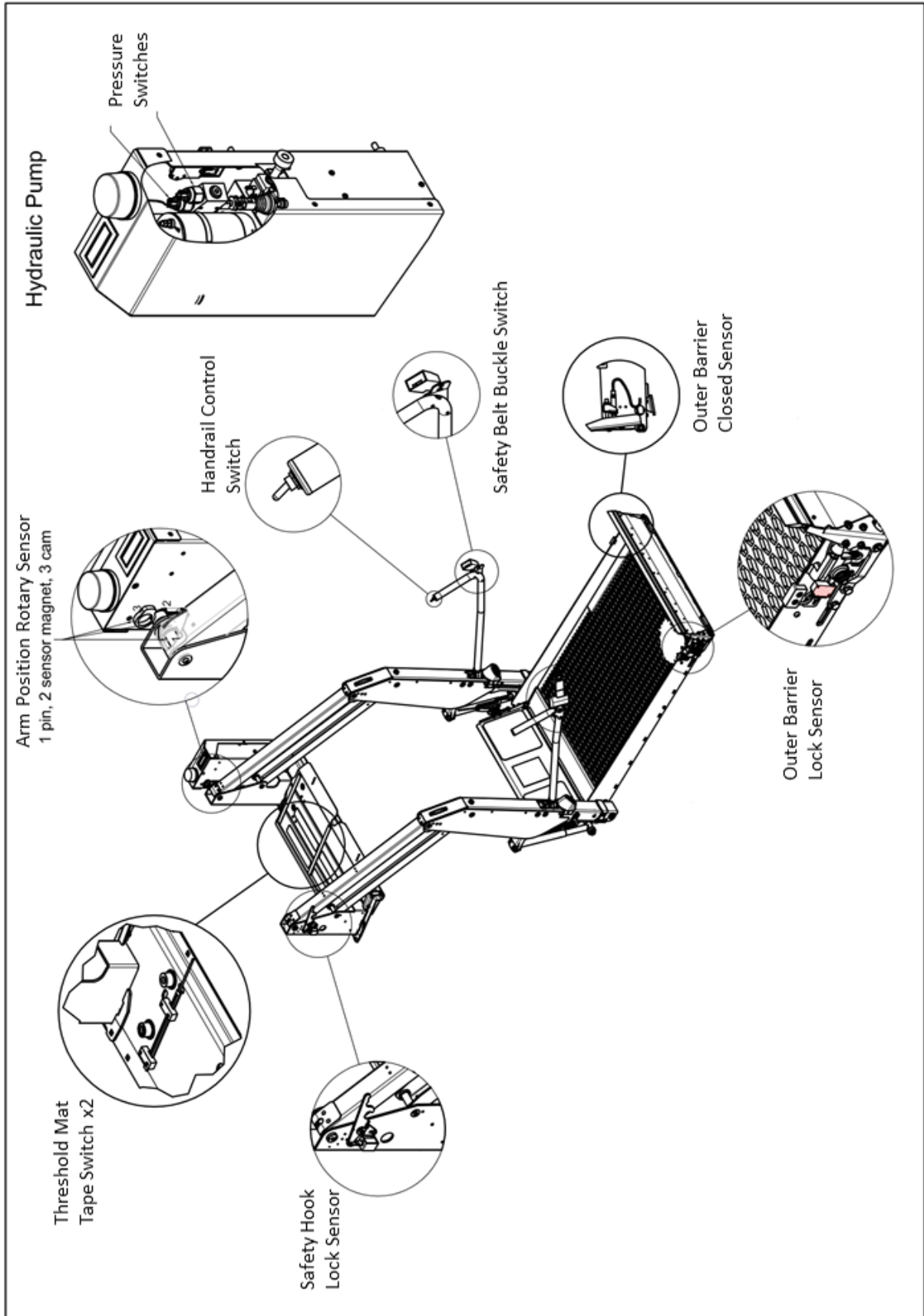

## 17.1 Lift Labelling

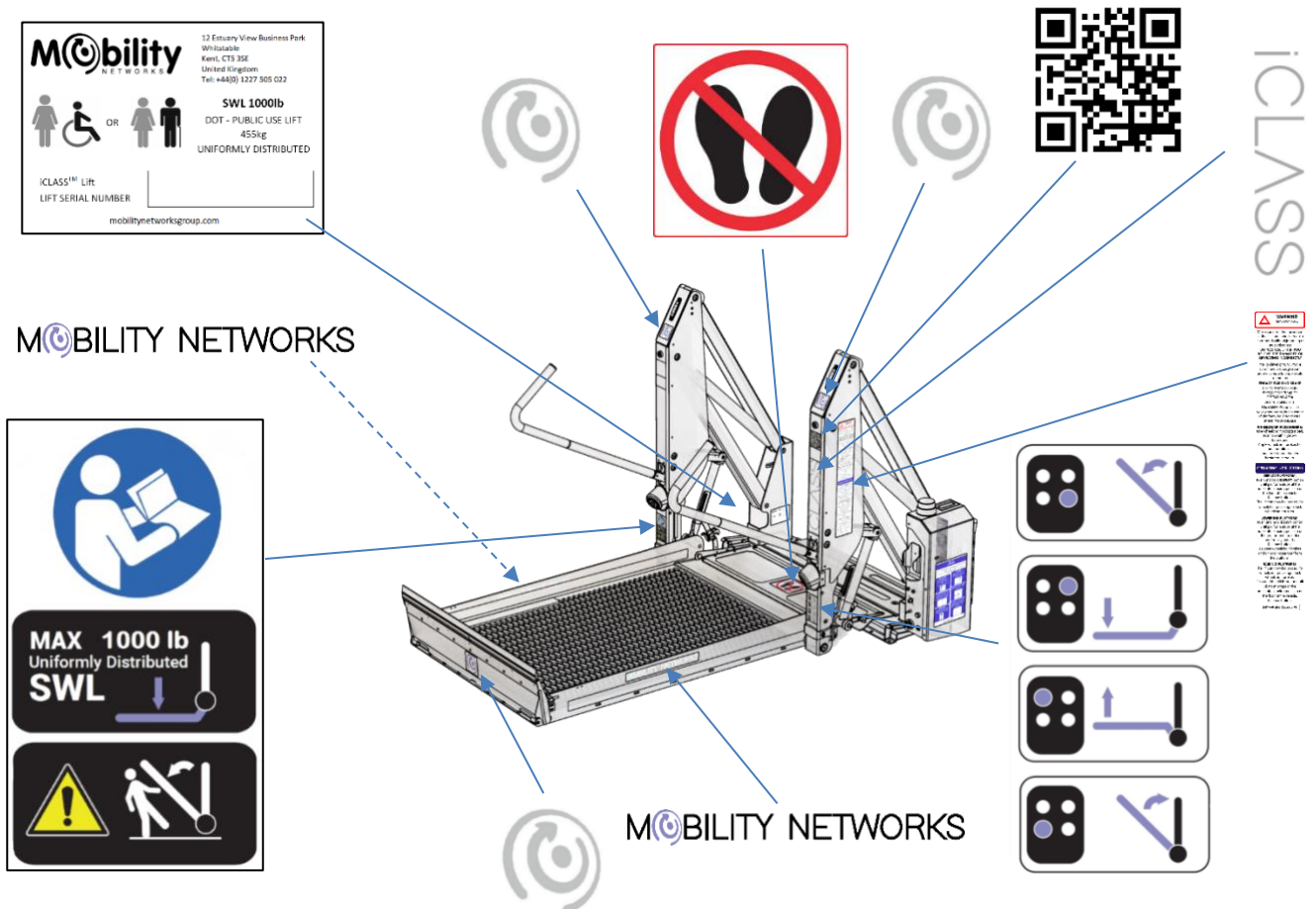

## 17.2 Power Pack Labels - Inside

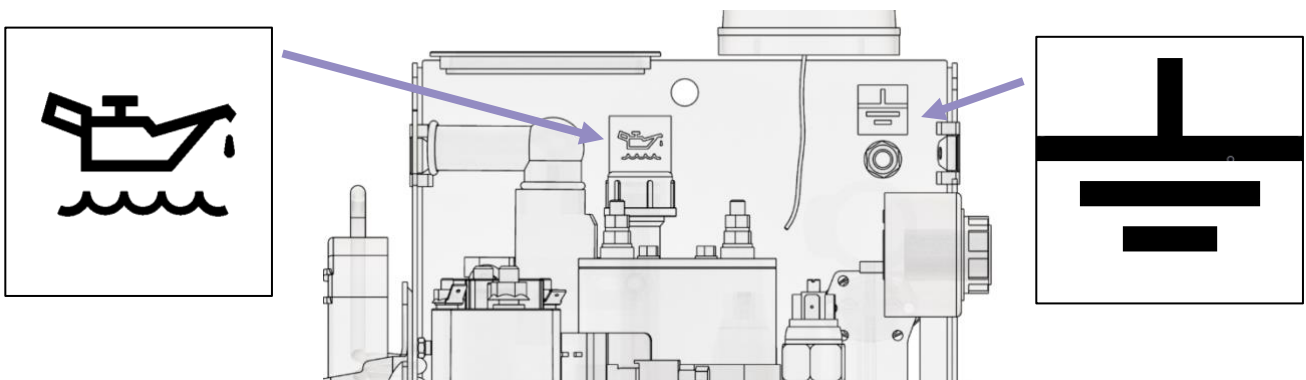

## 17.3 Power Pack Labels - Outside

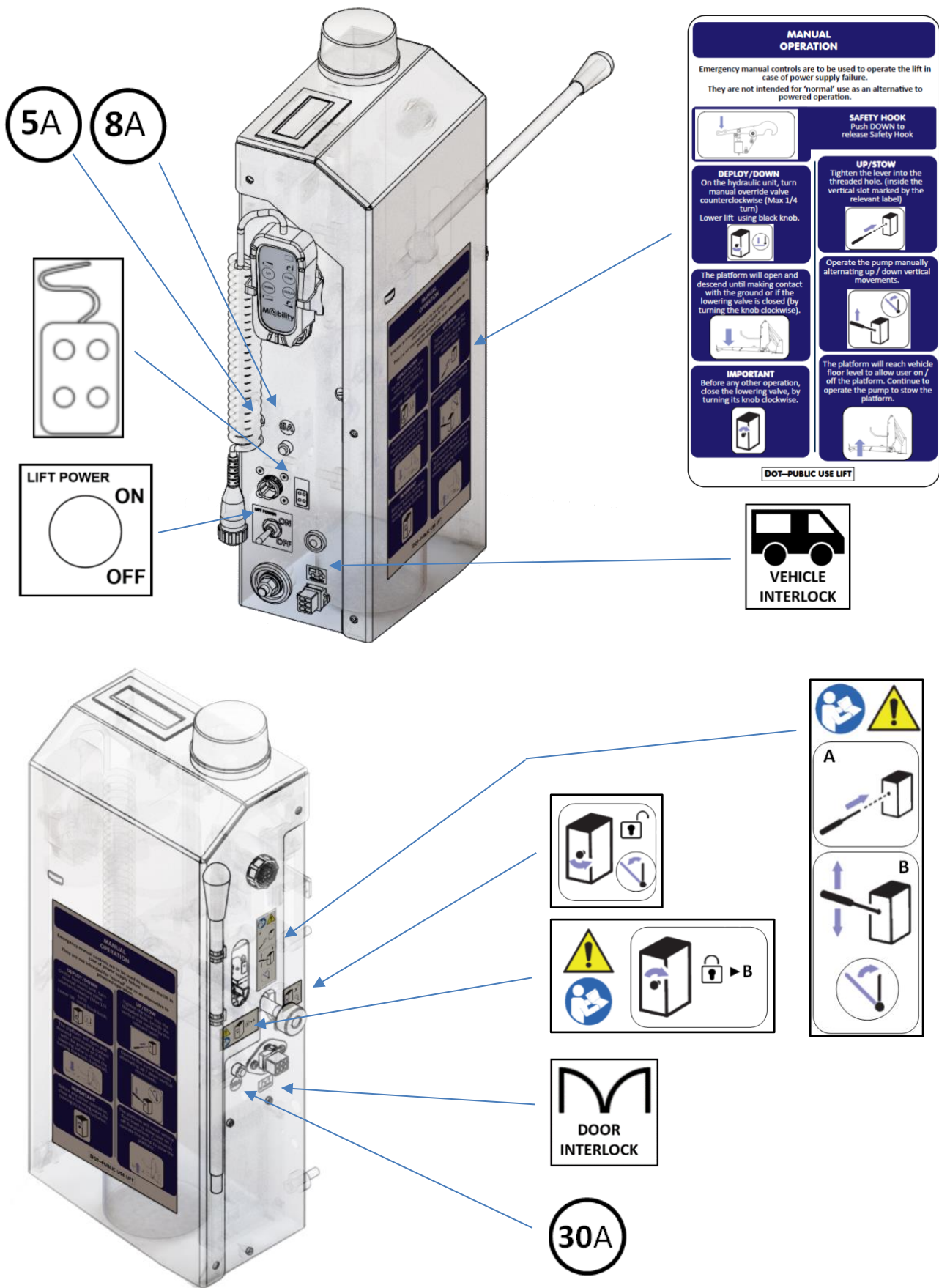



## WARNING

USE ONLY GENUINE iCLASS PARTS  
USE OF NON-GENUINE PARTS AND HARDWARE MAY VOID THE WARRANTY

### 18.1 iCLASS S Spares Summary

DRAWING	CODE	DESCRIPTION
TAV.1	KIT2005	Pin and fastener kit
TAV.2 SX (A)	KIT2010	Upper arm left kit
TAV.2 SX (B)	KIT2015	Pivot bushes kit
TAV.2 (C)	KIT2020	Arm end cover kit
TAV.2-SX (D)	KIT2025	Tube clamp collar kit
TAV.2-UNDER	KIT2030	Under arm kit
TAV.2-UPPER RIGHT	KIT2035	Upper arm kit right
TAV.3	KIT2040	Rail kit
TAV.4 (A)	KIT2045	Sensitive edges kit
TAV.4 (B)	KIT2050	Threshold springs kit
TAV.4 (C)	KIT2055	Sensitive threshold kit
TAV.5 (A)	KIT2060	Lifting cylinder kit
TAV.5 (B)	KIT2065	Hydraulic connection for 2-cylinder kit
TAV.5 (C)	KIT2068	Seals kit
TAV.6 (A)	KIT2070	Electromagnet for hook kit
TAV.6 (B)	KIT2075	Safety hook kit
TAV.6 (C)	KIT2080	Pin for safety hook kit
TAV.7	ASM1461	Outer arm frame kit
TAV.7 (B)	KIT2085	Frog light kit
TAV.7 (C)	KIT2090	Pivot pins kit
TAV.7 (D)	KIT2095	Arms panels
TAV.7 (E)	KIT2100	Strip LED kit

<b>DRAWING</b>	<b>CODE</b>	<b>DESCRIPTION</b>
TAV.7 (F)	KIT2105	Gas spring pins and spacer kit
TAV.7 (G)	KIT2110	Handrail adjuster bolts kit
TAV.7 (H)	KIT2115	Platform and handrails buffers kit
TAV.7 LEFT (I)	KIT2120	Small hose clamp kit
TAV.8 RIGHT	KIT2130	Telescopic right kit
TAV.8 LEFT	KIT2125	Telescopic left kit
TAV.8 RIGHT/LEFT	KIT2135	Rotational stowage arm kit
TAV.8 ( C )	MOL0013	Gas spring
TAV.9 RIGHT/LEFT	KIT2140	Knuckle joints handrails kit
TAV.9 RIGHT/LEFT	KIT2145	Handrails stop blocks
TAV.9 RIGHT/LEFT	KIT2150	Handrails pivot covers
TAV.9 RIGHT/LEFT	KIT2155	Handrails spring kit
TAV.10 (A)	KIT2160	Assembly front flap cylinder kit
TAV.10 (B)	KIT2165	Sliding system front flap cylinder kit
TAV.11 (A) right	KIT2170	Inner barrier linkage kit right
TAV.11 (A) left	KIT2175	Inner barrier linkage kit left
TAV.11 (B)	KIT2180	Inner barrier hook kit
TAV.12	KIT2185	Inner barrier kit
TAV.13 (A) Assembly1	KIT2190	Platform fixing kit
TAV.13 (B) Assembly1	KIT2195	Large hose clamp collar kit
TAV.13 (C) Assembly1	KIT2200	Switch cover plate kit
TAV.13 (A) Assembly2	KIT2205	Front flap safety hook kit
TAV.13 (B) Assembly2	KIT2210	Stowing platform buffer kit
TAV.13 (C) Assembly2	KIT2215	Switch front flap 2 kit
TAV.13 (D) Assembly2	KIT2220	Rubber buffer front flap kit
TAV.13 (E) Assembly2	KIT2222	Mechanism cover
TAV.13 (A) Assembly3	KIT2225	Sliding system front flap cylinder kit
TAV.13 (B) Assembly3	KIT2230	Mobility platform cover kit
TAV.13 (C) Assembly3	KIT2235	Switch front flap 1 kit
TAV.13 Assembly	KIT2188	Full assembled platform kit
TAV.14	KIT2240	Complete front flap kit
TAV.14(A)	KIT2245	Front flap alloy and rubber profile kit
TAV.14(B)	KIT2250	Front flap locking pin kit
TAV.14(C)	KIT2255	Main frame front flap kit



<b>DRAWING</b>	<b>CODE</b>	<b>DESCRIPTION</b>
TAV.15 (A)	KIT2260	Pressure switch kit
TAV.15 (B)	KIT2265	Suction tube kit
TAV.15 (C)	KIT2270	Oil filling hose kit
TAV.15 (D)	KIT2275	External Hydraulic fitting kit
TAV.15 (E)	KIT2280	Tank kit
TAV.15 (F)	KIT2282	Manifold kit

TAV.15 (A) Part.1	KIT2285	Electric motor kit.(12V.)
TAV.15 (B) Part.1	KIT2290	Hydraulic unit manifold fixing kit
TAV.15 (C) Part.1	KIT2295	Fixing kit for black plate power pack
TAV.15 (D) Part.1	KIT2300	Power pack right cover kit and fixings
	KIT2301	Power pack left cover kit and fixings
TAV.15 (E) Part.1	KIT2305	Lowering valve kit
TAV.15 (F) Part.1	KIT2310	Hand pump rod kit
TAV.15 (G) Part.1	KIT2315	LCD display kit
TAV.15 (I) Part.1	SPI0004	Signal lamp
TAV.15 (L) Part.1	LAS1953	Support plate right power pack
	LAS2077	Support plate left power pack

TAV.15 (N) Part.1	BUZ0005	Buzzer
TAV.15 (A) Part.2	KIT2320	Earthing bolt kit
TAV.15 (B) Part.2	KIT2325	Rotary sensor kit
TAV.15 (C) Part.2	KIT2330	Isolator solenoid kit
TAV.15 (D) Part.2	KIT2335	ECU kit
TAV.15 (E) Part.2	KIT2340	Resettable circuit breakers kit
TAV.15 (F) Part.2	KIT2345	Hand controller kit
TAV.15 (G) Part.2	INT0038	Power switch
TAV.15 (H) Part.2	CON0100	BATTERY THROUGH PANEL
TAV.15 (L) Part.2	KIT2350	Adapter flange door open connector
TAV.15 (M) Part.1	KIT2355	Power pack kit
TAV.16 (A)	KIT2360	Hydraulic hose kit
TAV.16 (B)	#503103	Fitting
TAV. 17 (A)	KIT2365	Hydraulic drainage hoses kit
TAV.18 (A)	KIT 2370	Public Handrails kit
TAV18 (B)	KIT 2375	Private Handrails kit
TAV. 19 (A)	KIT 2380	Switch joystick kit
TAV. 19 (B)	KIT 2385	Support safety belt
TAV.19 (C)	KIT2390	Safety belt kit
TAV. 19 (D)	KIT2395	Switch joystick and safety belt

KIT2001 : MAIN BASE				
Pos.	Quantity	Code	Description	NOTE
A1	1	ASM1483	MAIN BASE	

KIT2005 : BASE FASTENER KIT				
Pos.	Quantity	Code	Description	NOTE
B1	2	PER0166	MAGNET PIN	
B2	6	#501878	SCREW TBEI M6X10	
B3	6	RON0034	WASHER Ø6	
B4	2	PER0015	PIN Ø20	
B5	4	502531	BUSH	
B6	1	PAS0003	RUBBER GROMMET	
B7	2	VIT0172	GRUB M6X12	

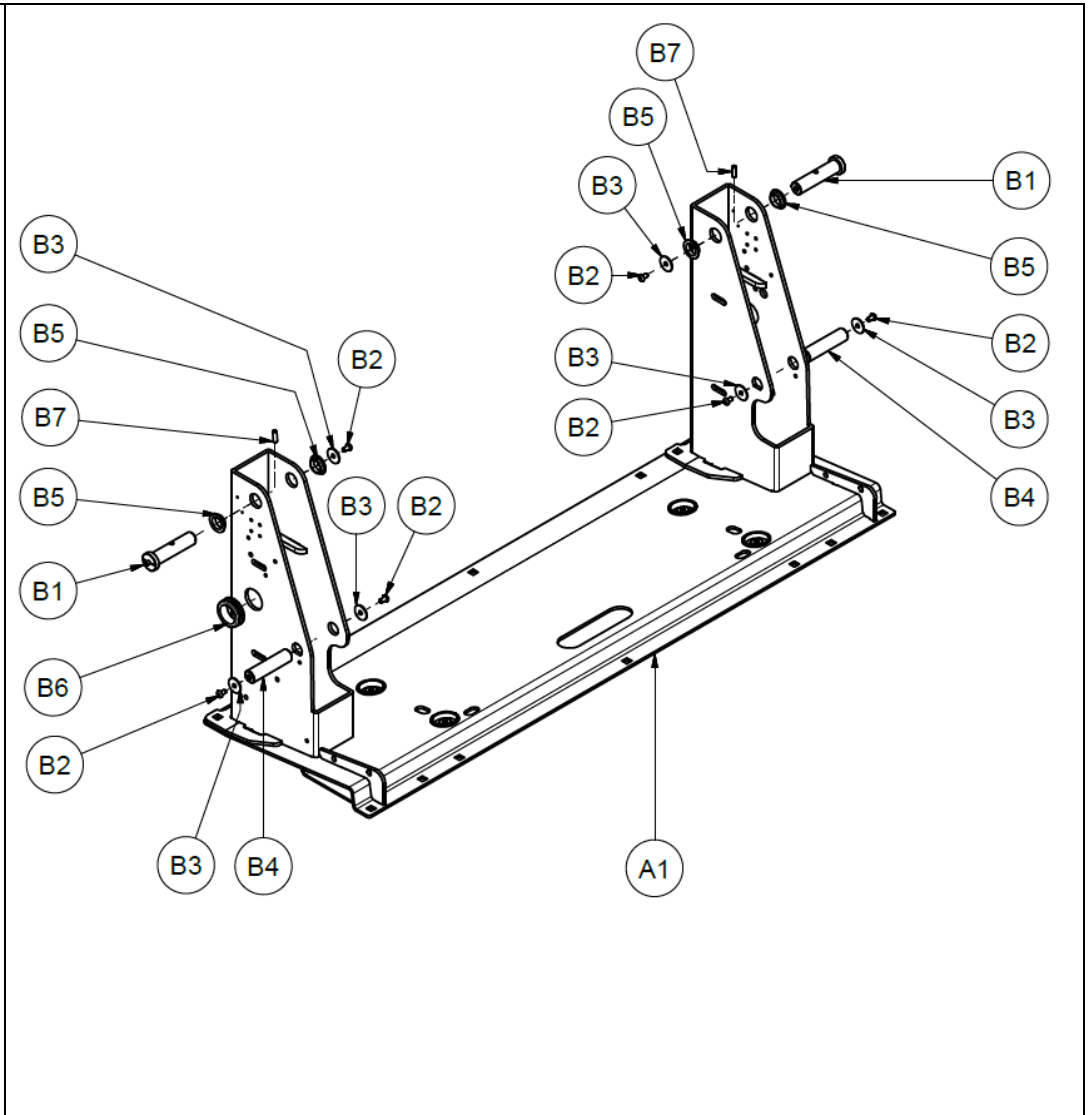

KIT2010 : UPPER ARM KIT LEFT				
Pos.	Quantity	Code	Description	NOTE
A2	1	ASM1511	UPPER LEFT ARM	
B1	4	BOC0023	BUSH	
C1	1	LAS1614	COVER	
C2	4	501911	RIVET	
C3	1	LAS2015	COVER LEFT	
D1	2	#550989	SUPPORT PIPE	
D2	4	VIT0192	SCREW TBEI M6X14	

KIT2015 : PIVOT BUSH				
Pos.	Quantity	Code	Description	NOTE
B1	4	BOC0023	BUSH	for any arm

KIT2020 : COVER OF ARMS				
Pos.	Quantity	Code	Description	NOTE
C1	3	LAS1614	COVER	
C3	1	LAS2015	COVER LEFT	
C2	8	501911	RIVET	

KIT2025 : PIPE CLAMP KIT				
Pos.	Quantity	Code	Description	NOTE
D1	2	#550989	SUPPORT PIPE	
D2	4	VIT0192	SCREW TBEI M6X14	

KIT2030 : UNDER ARM				
Pos.	Quantity	Code	Description	NOTE
A3	1	ASM1317	UNDER ARM	
A2	4	BOC0023	BUSH	

KIT2035 : UPPER ARM KIT RIGHT				
Pos.	Quantity	Code	Description	NOTE
A1	1	ASM1316	UPPER RIGHT ARM	
B1	4	BOC0023	BUSH	
C1	2	LAS1614	COVER	
C2	4	501911	RIVET	

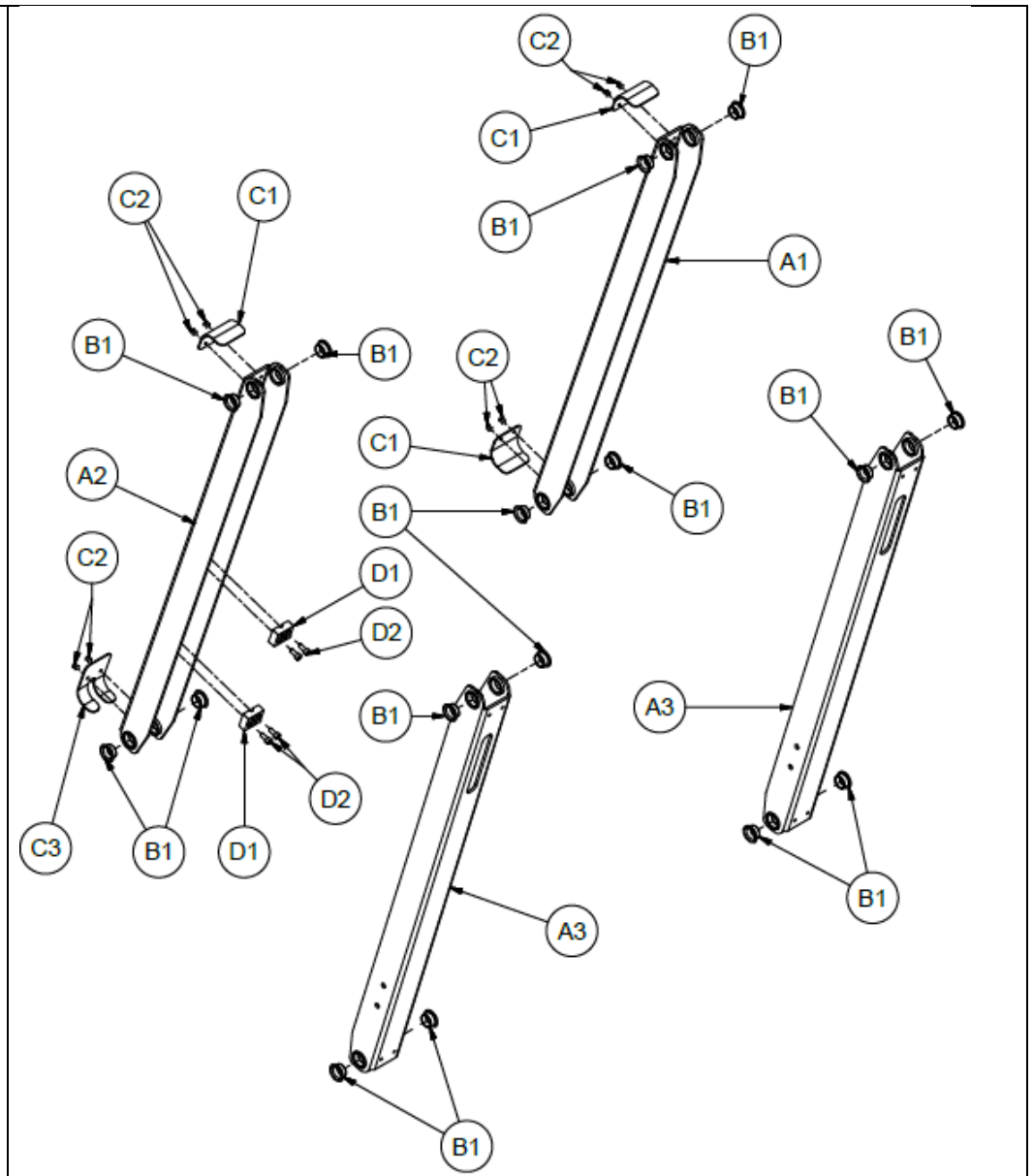

KIT2040 : RAIL KIT				
Pos.	Quantity	Code	Description	NOTE
A1	1	LAS1984	RIGHT RAIL	
A2	1	LAS1985	LEFT RAIL	
A3	4	#500429	SCREW TE M8X20	
A4	12	RON0001	WASHER	
A5	4	DAD0034	NUT	

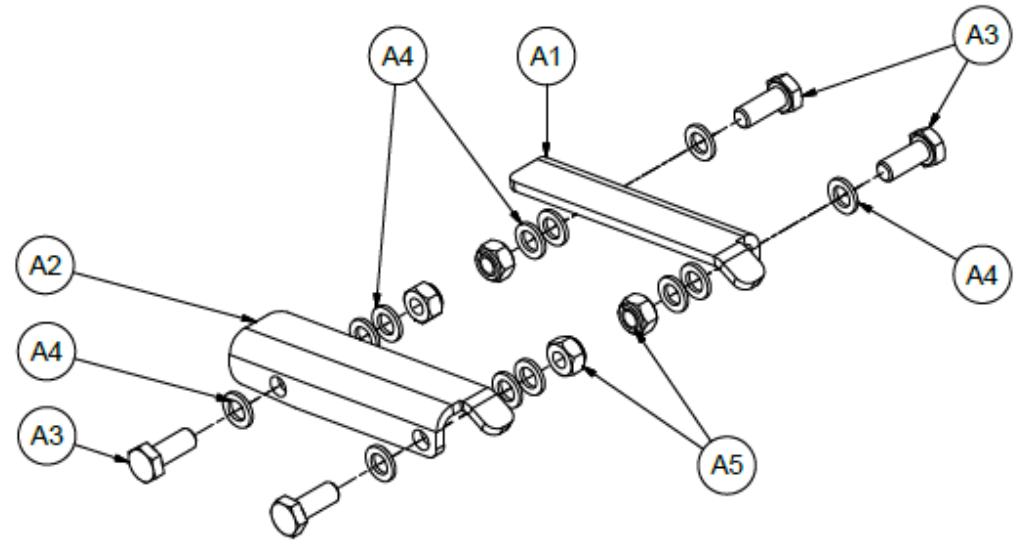

KIT2045 : THRESHOLD WARNING SWITCH KIT				
Pos.	Quantity	Code	Description	NOTE
A1	2	CAB0195	TAPE SWITCH	

KIT2050 : THRESHOLD SPRINGS KIT				
Pos.	Quantity	Code	Description	NOTE
B1	2	MOL0070	HIGH SPRING	YELLOW
B2	2	MOL0071	SPRING	
B3	4	#C402013	WASHER	CHROME

KIT2055 : THRESHOLD WARNING KIT				
Pos.	Quantity	Code	Description	NOTE
C1	1	ASM1480	EXTRUSION	
C2	Mt.1,1	NAS0010	SLIDE	
C3	Mt.0,81	PRF0472	RUBBER PROFILE	
C4	4	RTO0044	SAFETY	
C5	4	BLO0097	SPACER	
C6	8	#551480	BOLT TSPEI M4X16	
C7	4	PER0356	PIN	

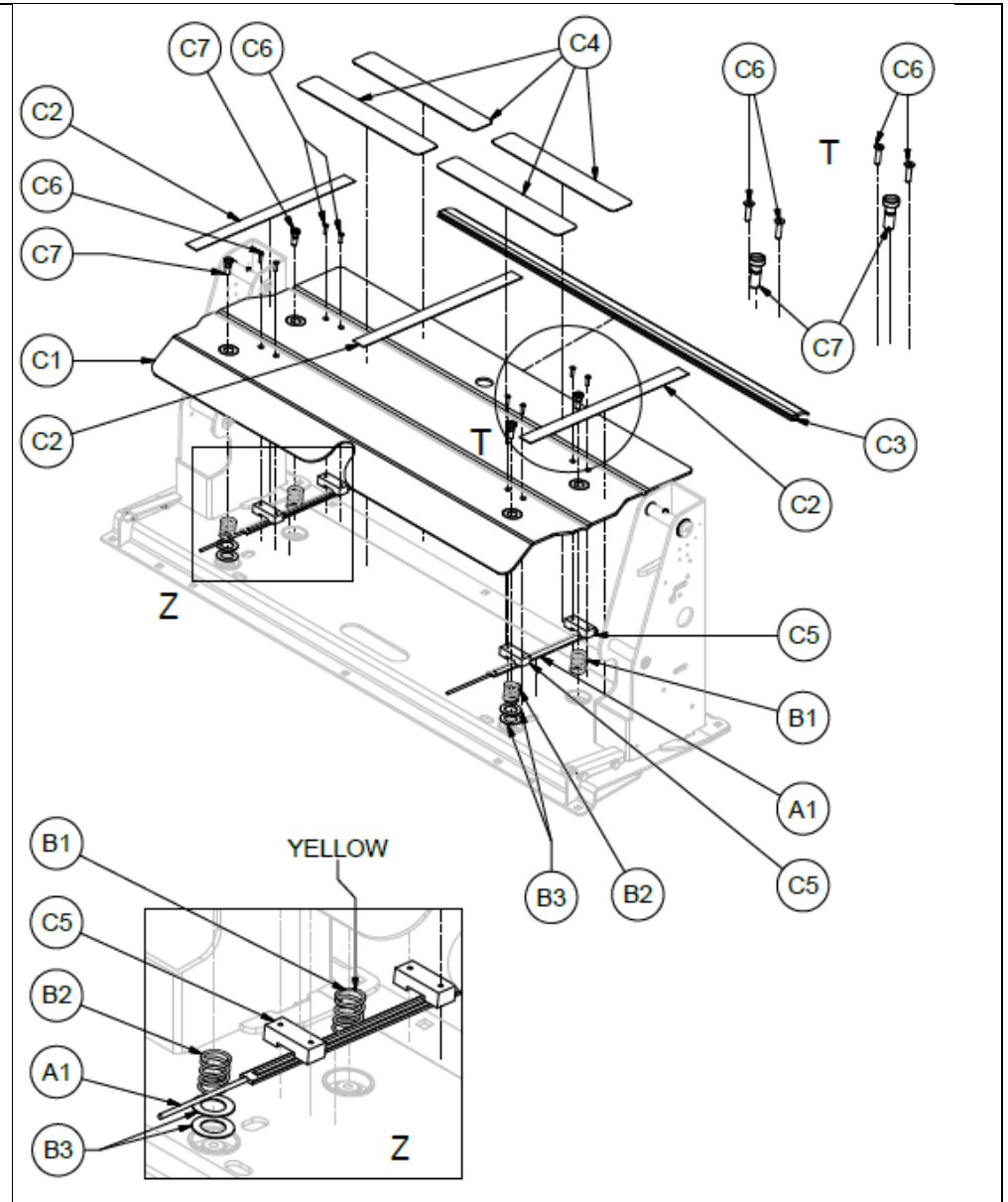

KIT2060 : LIFTING CYLINDER KIT				
Pos.	Quantity	Code	Description	NOTE
A1	1	CIL0082	CYLINDER	
A2	4	BOC0023	BUSH	
A3	1	VIT0172	GRUB M6X12	
A4	1	RAC0045	FITTING	

KIT2065 : CYLINDER KIT FITTINGS				
Pos.	Quantity	Code	Description	NOTE
B1	2	RAC0041	1/8 FITTING	
B2	4	550200	WASHER	
B3	2	VIT0169	THROTTLE GRUB M6	

KIT2068 : SEALS KIT				
Pos.	Quantity	Code	Description	NOTE
A1	1	KIT0327	SEALS KIT	

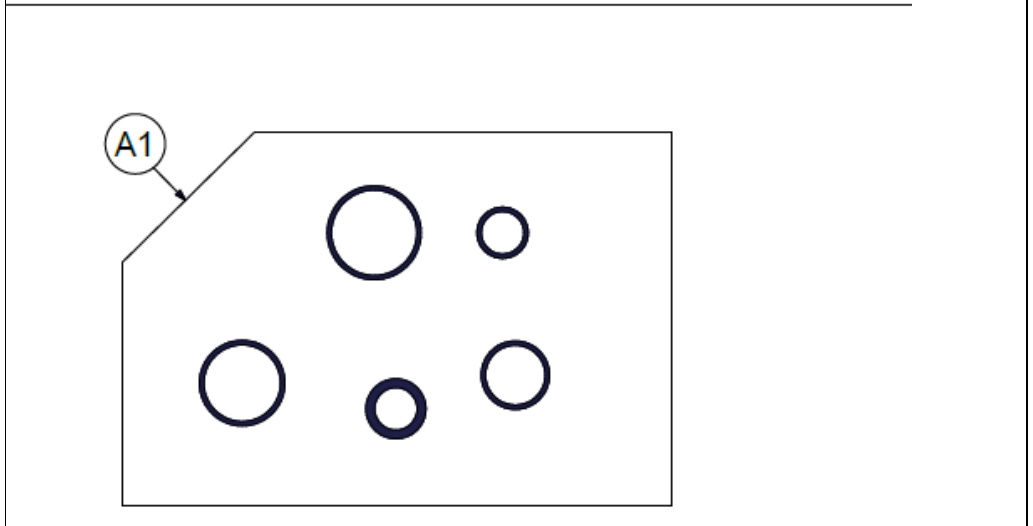
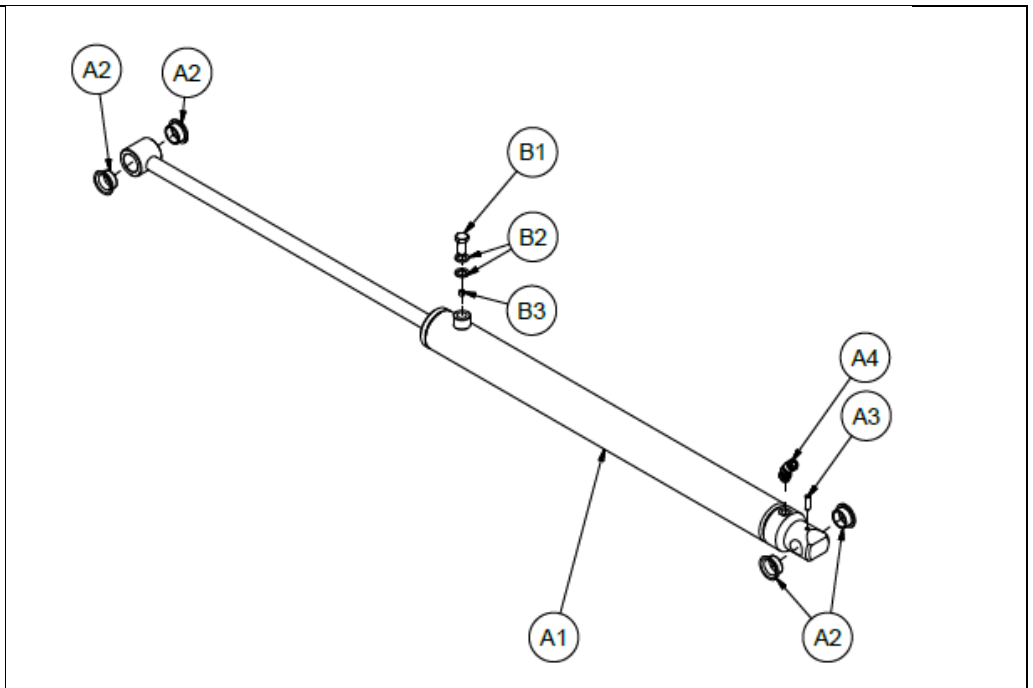

KIT2070 : ELECTROMAGNET KIT				
Pos.	Quantity	Code	Description	NOTE
A1	1	FOR0005	FORK	
A2	1	CAB0197	ELECTROMAGNET	
A3	1	PER0362	PIN OF FORK	
A4	1	VIT0205	BLOCK	

KIT2075 : SAFETY HOOK				
Pos.	Quantity	Code	Description	NOTE
B1	1	LAS2188	BLOCK	
B2	2	VIT0077	SCREW TSPEI M3X5	
B3	3	VIT0141	SCREW TBEI M6X12	
B4	3	RON0002	WASHER Ø6	
B5	1	RON0034	WASHER Ø6	
B6	1	ASM1591	SUPPORT BLOCK	
B7	2	RON0039	WASHER Ø12	
B8	1	DAD0032	NUT M6	
B9	1	BOC0299	BUSH	
B10	1	MOL0072	SPRING	

KIT2080 : PIN FOR SAFETY HOOK				
Pos.	Quantity	Code	Description	NOTE
C1	1	ASM1590	PIN	
C2	2	VIT0210	SCREW TE M8X18	
C3	2	RON0001	WASHER Ø8	
C4	2	VIT0143	SCREW TBEI M8X16	
C5	2	PER2023	SPACER PIN	

INCLUDED IN THE DOOR OPENER KIT				
Pos.	Quantity	Code	Description	NOTE
D1	1	LAS2189	EXTENSION BLOCK	
D2	2	DAD0025	NUT M5	
D3	2	VIT0197	SCREW TBEI M5X16	

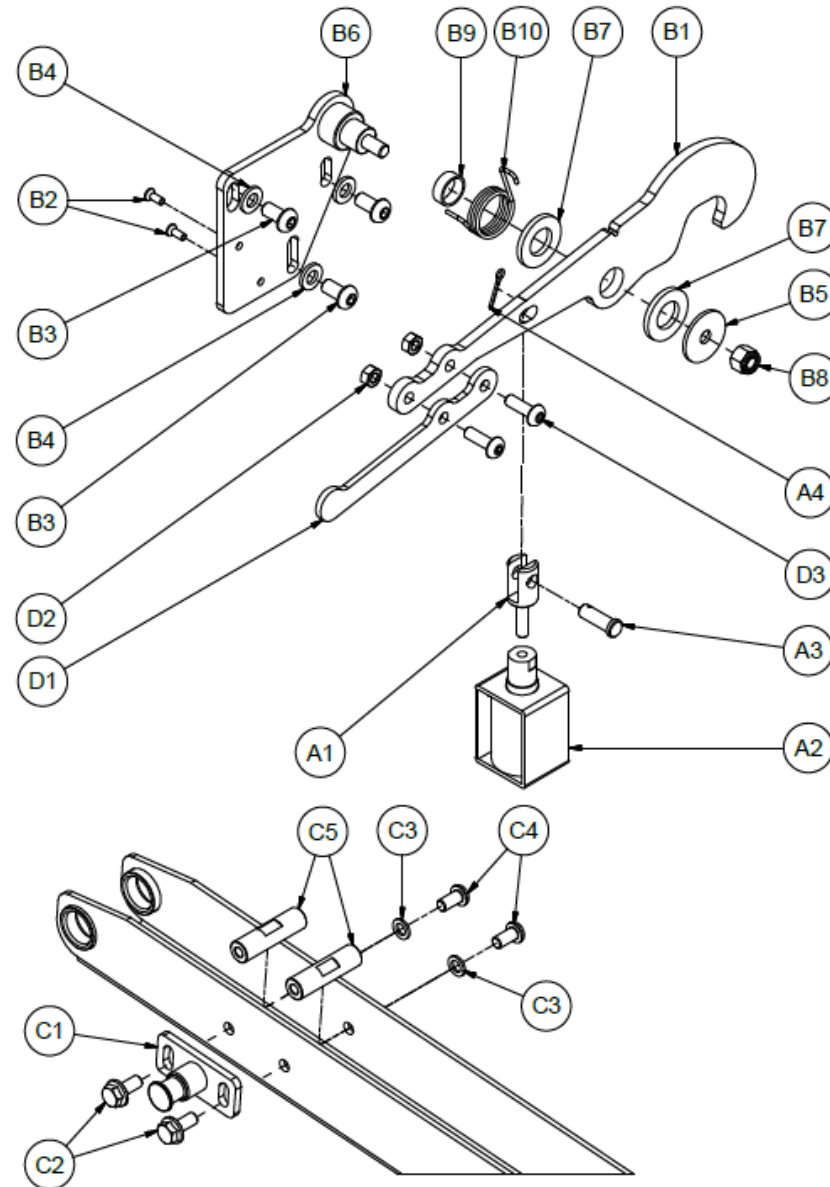

OUTER ARM FRAME				
Pos.	Quantity	Code	Description	NOTE
A1	1	ASM1481	VERTICAL ARM	

KIT2085 : FROG LIGHT KIT				
Pos.	Quantity	Code	Description	NOTE
B1	1	COP0081	RIGHT COVER	
B2	2	CAB0172	FROG LIGHT	
B3	1	COP0082	LEFT COVER	
B4	4	VIT0185	SCREW TBEI M5X8	

KIT2090 : PIVOT PINS KIT				
Pos.	Quantity	Code	Description	NOTE
C1	8	PER0015	PIN Ø20	
C2	16	RON0034	WASHER Ø6	
C3	16	#501878	SCREW TBEI M6X10	

KIT2095 : ARMS PANEL				
Pos.	Quantity	Code	Description	NOTE
D1	2	PAN0055	LEFT PANEL	
D2	2	PAN0056	RIGHT PANEL	
D3	20	VIT0185	SCREW TBEI M5X8	

KIT2100 : STRIP LEDS LIGHT				
Pos.	Quantity	Code	Description	NOTE
E1	2	CAB0077	SQUARE LIGHT	
E2	2	CAB0184	LED LIGHT	
E3	8	VIT0056	SCREW TBTC M3X10	

KIT2105 : HANDRAIL ADJUSTER BOLTS				
Pos.	Quantity	Code	Description	NOTE
F1	4	PER0020	SPRING PIN	
F2	8	RUO0007	SPACER WHEEL	
F3	8	501382	CIRCLIP	

KIT2110 : PLATFORM AND HANDRAILS BUFFERS KIT				
Pos.	Quantity	Code	Description	NOTE
G1	4	DAD0035	NUT M8	
G2	4	DAD0040	GRUB M8	



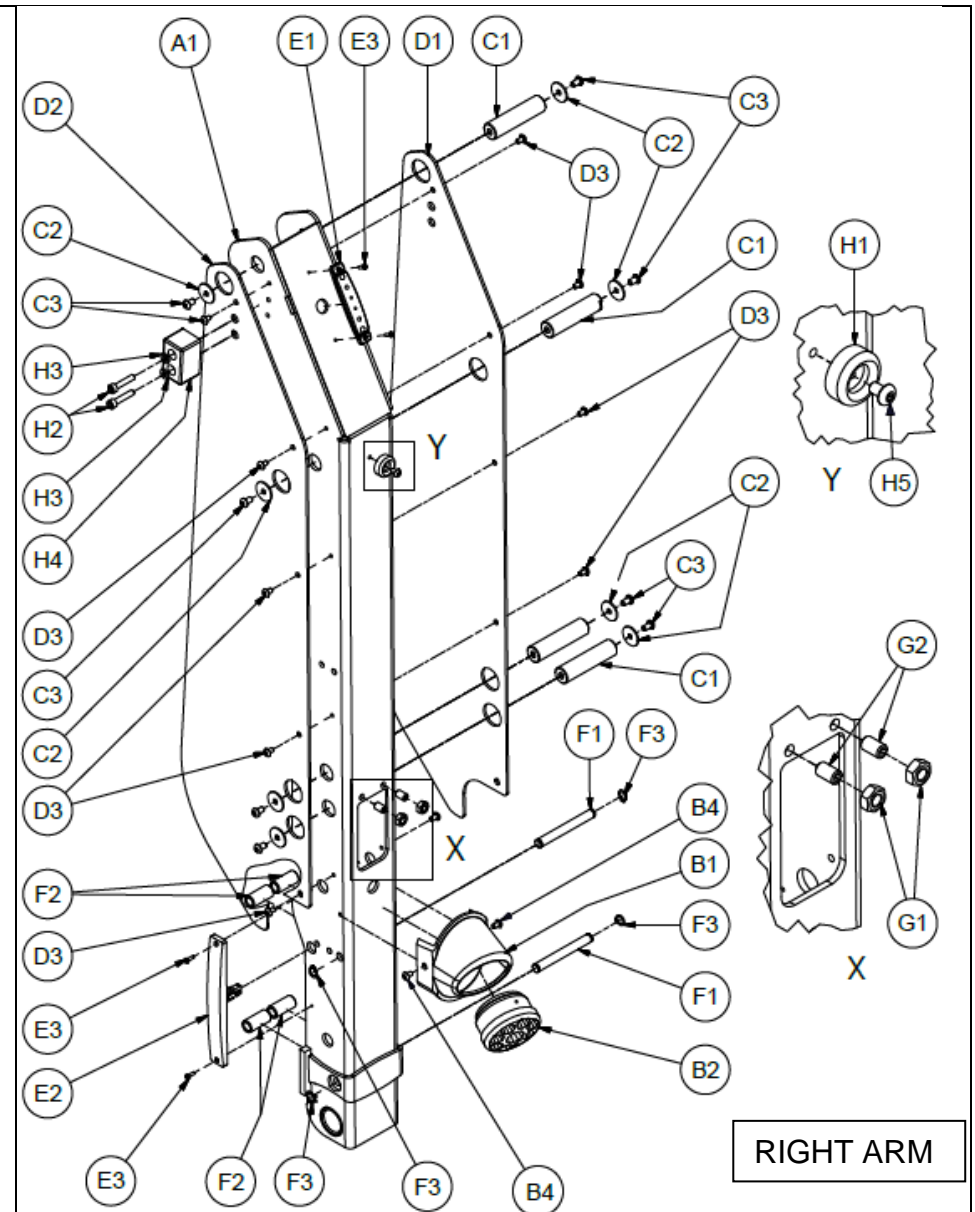

KIT2115 : BUFFER KIT				
Pos.	Quantity	Code	Description	NOTE
H1	2	#550887	ROUND BUFFER	
H2	4	#501750	SCREW TCEI M6X30	
H3	4	RON0002	WASHER Ø6	
H4	2	551314	BUFFER	
H5	2	VIT0185	SCREW TBEI M5X8	

KIT2120 : SMALL HOSE CLAMP KIT				
Pos.	Quantity	Code	Description	NOTE
I1	2	#550989	HOSE CLAMP	ON LEFT ARM
I2	4	VIT0192	SCREW TCEI M6X14	ON LEFT ARM

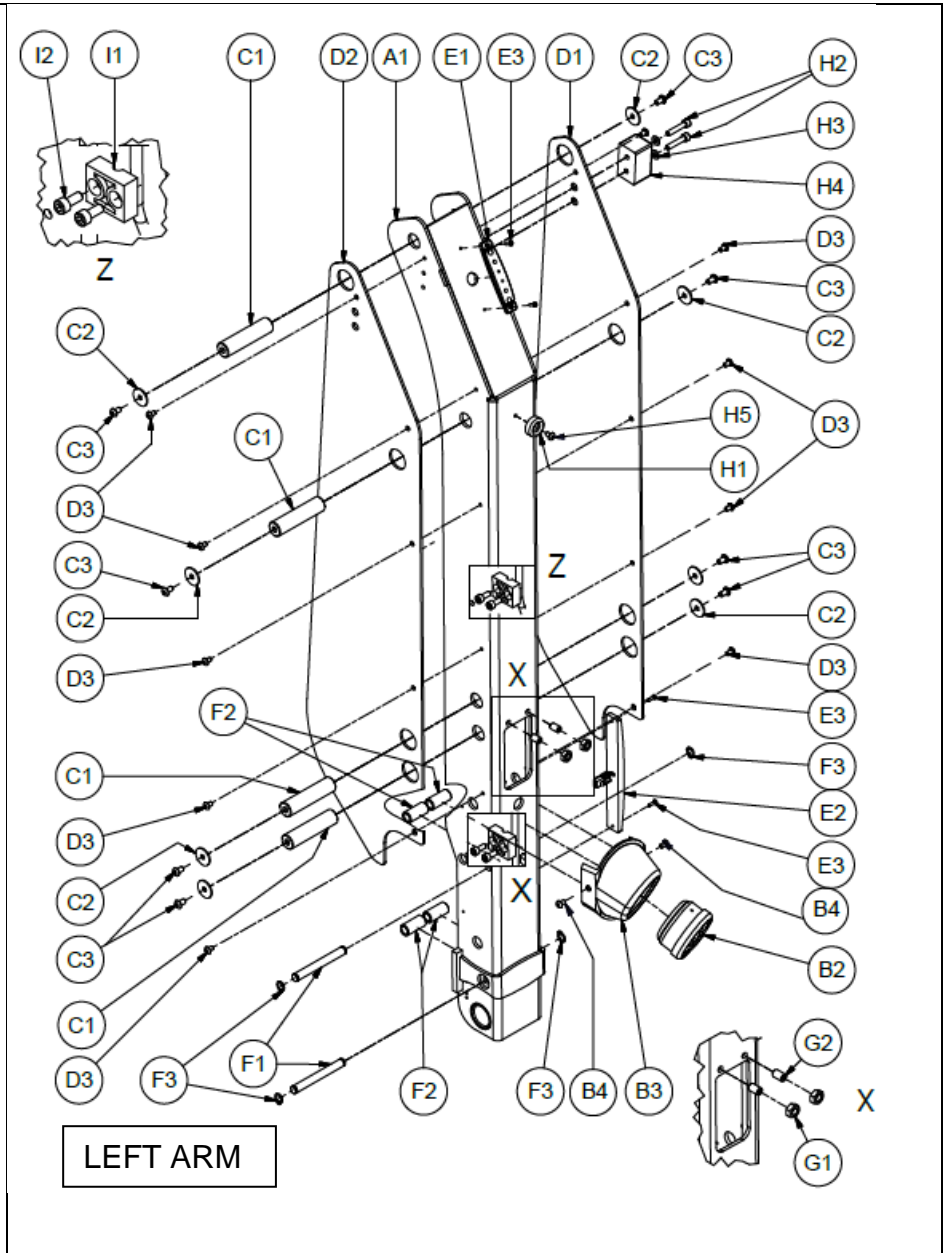

Lift Installation and Maintenance must be performed by an approved engineer.  
 Non-compliance may result in serious personal injury, damage to the vehicle and may affect or even void the product warranty.

KIT2125 : TELESCOPIC KIT LEFT				
Pos.	Quantity	Code	Description	NOTE
A2	1	ASM0688	KNEE ASSEMBLY	
A3	1	ASM1487	TELESCOPIC PIPE	
A4	2	BOC0023	BUSH	

KIT2130 : TELESCOPIC KIT RIGHT				
Pos.	Quantity	Code	Description	NOTE
A1	1	ASM1488	TELESCOPIC PIPE	
A2	1	ASM0688	KNEE ASSEMBLY	
A4	2	BOC0023	BUSH	

KIT2135 : ROTATIONAL STOWAGE ARM KIT				
Pos.	Quantity	Code	Description	NOTE
B1	1	ASM1394	KNEE ASSEMBLY	
B2	1	RUO0004	WHEEL	
B3	1	PER0019	SPRING PIN	
B4	1	PER0014	PIN Ø15	
B5	1	PIA0657	SPACER	
B6	1	PER0015	PIN Ø20	
B7	2	RUO0006	SPACER WHEEL	
B8	2	RON0031	WASHER Ø5	
B9	2	#500376	SCREW TE M5X14	
B10	2	RON0050	CIRCLIP	
B11	2	BOC0024	BUSH	
B12	2	RON0034	WASHER Ø6	
B13	2	#501878	SCREW TBEI M6X10	

KIT2140 : GAS SPRING				
Pos.	Quantity	Code	Description	NOTE
C1	1	MOL0013	GAS SPRING	

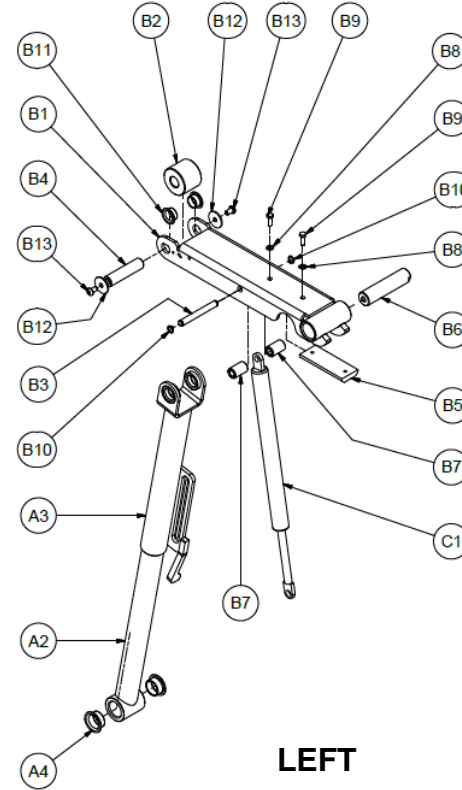

**LEFT**

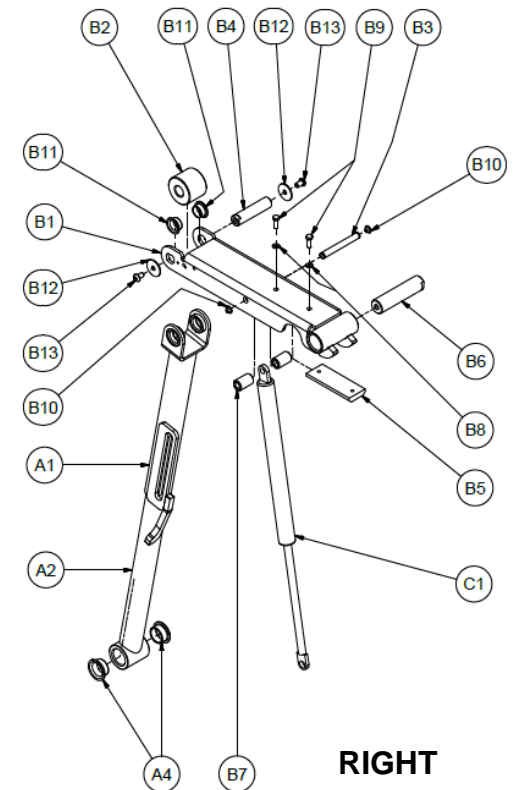

**RIGHT**

KIT2140 : KNUCKLE JOINTS HANDRAILS KIT				
Pos.	Quantity	Code	Description	NOTE
A1	1	ASM1506	HANDRAIL SUPPORT	RIGHT
A2	2	RUO0003	SPACER WHEEL	
A3	4	PER0013	SPRING PIN	
A4	2	#501761	SCREW TCEI M8X30	
A5	4	BOC0023	BUSH	
A6	2	551095	BUSH	
A7	8	RON0050	CIRCLIP	
A8	4	RUO0099	SPRING WHEEL	
A9	1	ASM1507	HANDRAIL SUPPORT	LEFT

KIT2145 : HANDRAILS STOP BLOCKS				
Pos.	Quantity	Code	Description	NOTE
B1	6	DAD0030	NUT M8	
B2	10	RON0001	WASHER	
B3	2	BLO0101	LEFT BLOCK	
B4	2	BLO0102	RIGHT BLOCK	
B5	2	VIT0213	SCREW TBEI M8X70	

KIT2150 : HANDRAILS PIVOT COVERS				
Pos.	Quantity	Code	Description	NOTE
C1	2	LAS2179	COVER	
C2	4	VIT0147	SCREW TBEI M5X10	

KIT2155 : HANDRAILS SPRING KIT				
Pos.	Quantity	Code	Description	NOTE
D1	2	MOL0026	SPRING	

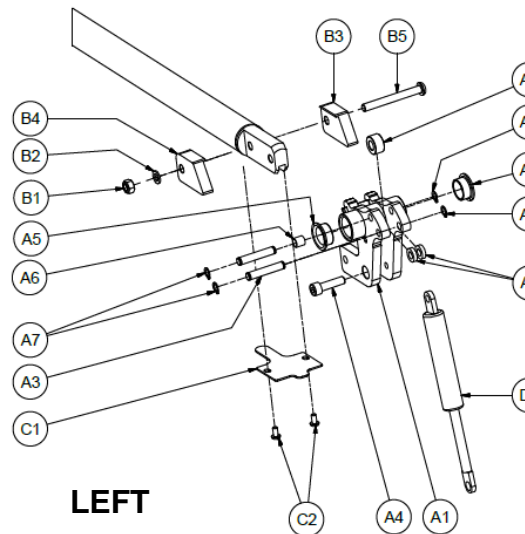
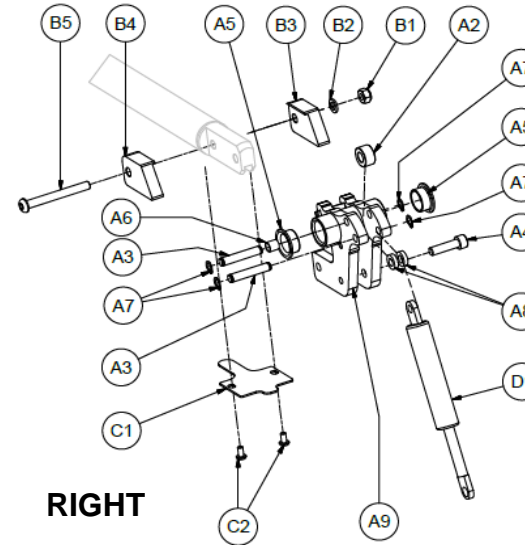

KIT2160 : ASSEMBLY FRONT FLAP CYLINDER KIT				
Pos.	Quantity	Code	Description	NOTE
A1	1	CIL0084	FLAP CYLINDER	
A2	1	#550062	JUNCTION $\varnothing 6 \frac{1}{8}$ "	
A3	1	#550140	COMPRESSION OLIVE	
A4	1	#550141	NUT $6 \frac{1}{8}$ "	

KIT2165 : SLIDING SYSTEM FRONT FLAP CYLINDER KIT				
Pos.	Quantity	Code	Description	NOTE
B1	2	BOC0265	BUSH	
B2	1	VIT0179	SCREW TE M8X75	
B3	1	BOC0042	SPACER BUSH	
B4	1	DAD0034	NUT M8	
B5	1	BLO0096	BLOCK	
B6	1	PER9022	PIN	
B7	2	501380	CIRCLIP	

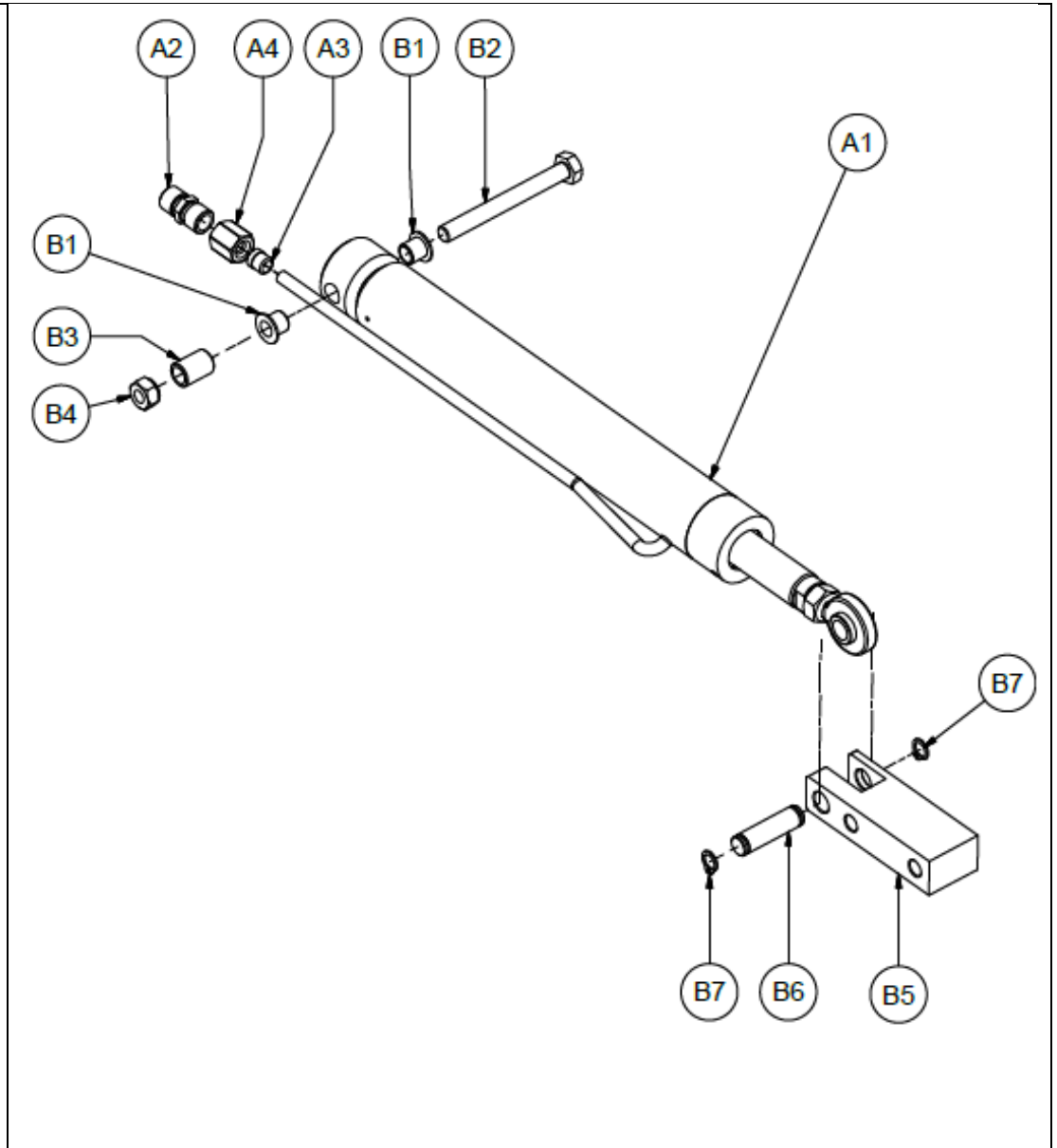

KIT2170 : INNER BARRIER LINKAGE KIT RIGHT				
Pos.	Quantity	Code	Description	NOTE
A1	1	ASM1484	RIGHT ROD	
A2	4	RON0005	LARGE WASHER	
A3	2	BOC0270	BUSH	
A4	2	#C402002	WASHER	
A5	2	#502334	BUSH	
A6	2	MOL0068	SPRING	

KIT2175 : INNER BARRIER LINKAGE KIT LEFT				
Pos.	Quantity	Code	Description	NOTE
A7	1	ASM1485	LEFT ROD	
A2	2	RON0005	LARGE WASHER	
A3	1	BOC0270	BUSH	
A4	1	#C402002	WASHER	
A5	1	#502334	BUSH	
A6	1	MOL0068	SPRING	

KIT2180 : INNER BARRIER HOOK KIT				
Pos.	Quantity	Code	Description	NOTE
B1	2	PER0353	PIN	
B2	1	LAS2002	BLOCK RIGHT	
B3	1	LAS2003	BLOCK LEFT	
B4	2	501100	NUT M5	
B5	10	VIT0185	SCREW TBEI M5X8	
B6	2	LAS2004	LOCK HOOK	
B7	4	BOC0035	BUSH	
B8	2	VIT0207	SCREW TCEI M5X12	

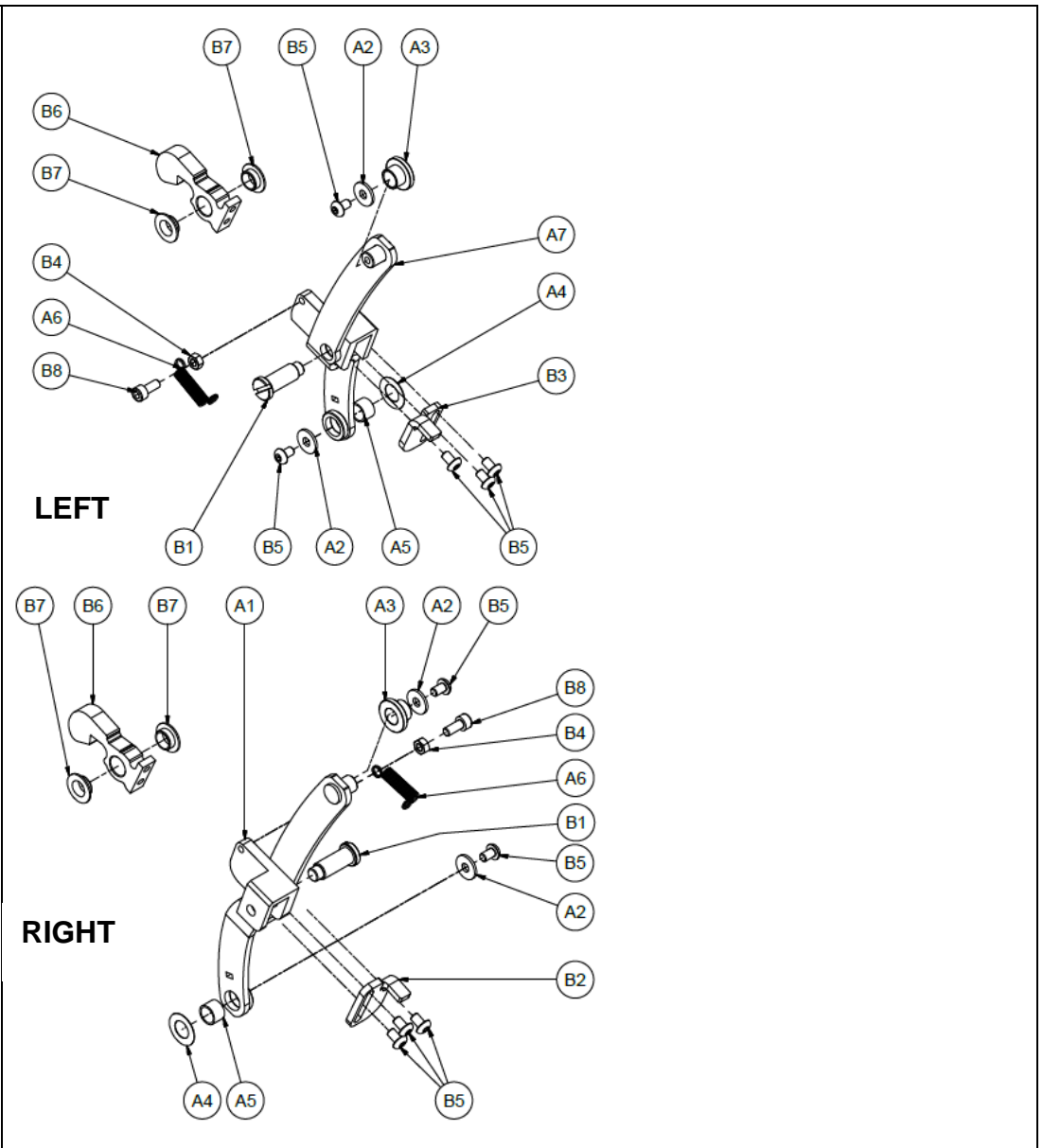

KIT2185 : INNER BARRIER KIT				
Pos.	Quantity	Code	Description	NOTE
A1	1	ASM1489	INTERNAL FLAP	
A2	2	ASM1486	PIN	
A3	1	#E499107	ADVISER STICKER	
A4	4	#551699	SCREW TSPEI M5X14	
A5	4	RON0031	WASHER Ø5	
A6	4	DAD0025	NUT M5	
A7	2	RTO0032	SAFETY GRIP	
A8	2	PER0306	PIN M12	
A9	2	BOC0263	BUSH	

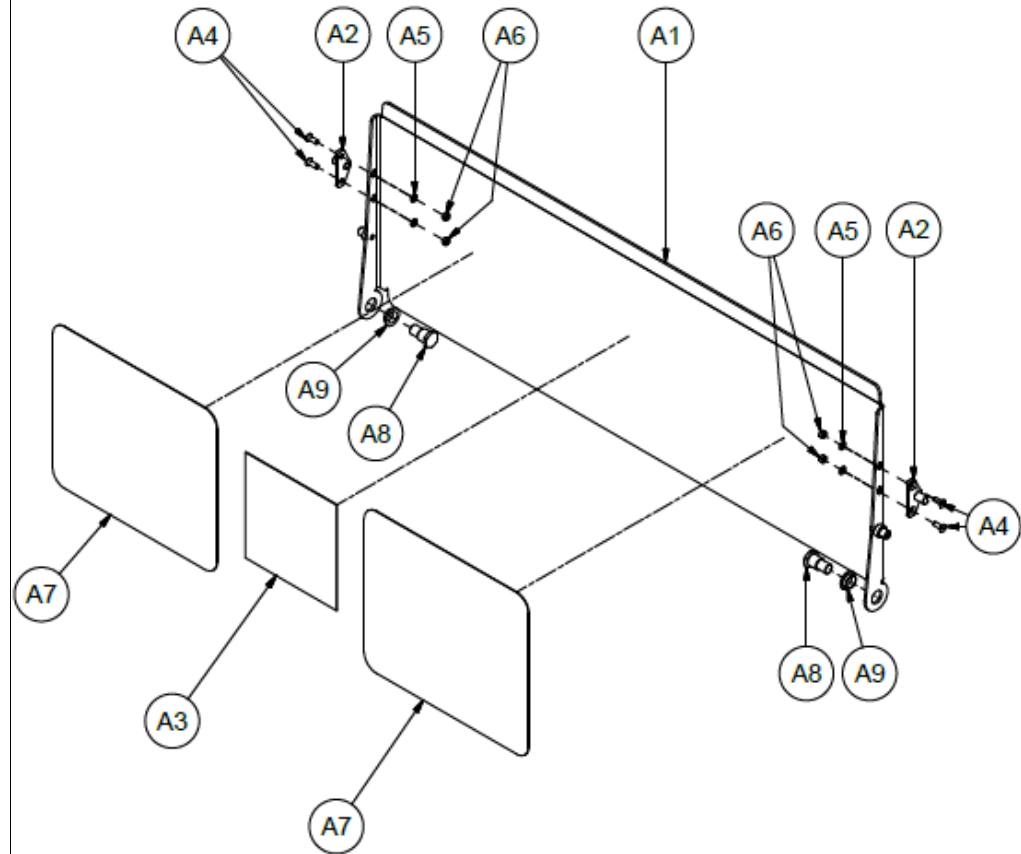

KIT2190 : PLATFORM FIXING KIT				
Pos.	Quantity	Code	Description	NOTE
A1	2	VIT0181	GRUB SCREW M14X25	
A2	7	#550515	FIXING PIPE	
A3	2	BOC0297	BUSH	
A4	2	RON0046	WASHER Ø14	
A5	2	#501157	NUT M14	
A6	2	RON0044	WASHER M8/35/4	
A7	2	#502160	SCREW TSPEI M8X20	
A8	4	RON0031	WASHER Ø5	
A9	4	VIT0197	SCREW TBEI M5X16	
A10	1	PIA0656	LEFT BLOCK	
A11	2	VIT0195	SCREW TCEI M14X30	
A12	7	VIT0185	SCREW TBEI M5X8	
A13	2	#502146	SCREW TSPEI M5X20	
A14	2	RON0030	WASHER Ø8/24	
A15	2	BOC0029	BUSH	
A16	2	RUO0011	WHEEL	
A17	2	501392	CIRCLIP	
A18	2	#C402013	WASHER	
A19	2	LAS2008	SUPPORT PIPE	
A20	1	PIA0655	RIGHT BLOCK	
A21	4	TAP0006	SPACER	
A22	4	550404	RUBBER GROMMET	

KIT2195 : LARGE HOSE CLAMP COLLAR KIT				
Pos.	Quantity	Code	Description	NOTE
B1	4	#550581	COLLAR	
B2	4	#501747	SCREW TCEI M6X20	

KIT2200 : SWITCH COVER PLATE				
Pos.	Quantity	Code	Description	NOTE
C1	1	LAS2031	COVER	
C2	2	VIT0185	SCREW TBEI M5X8	

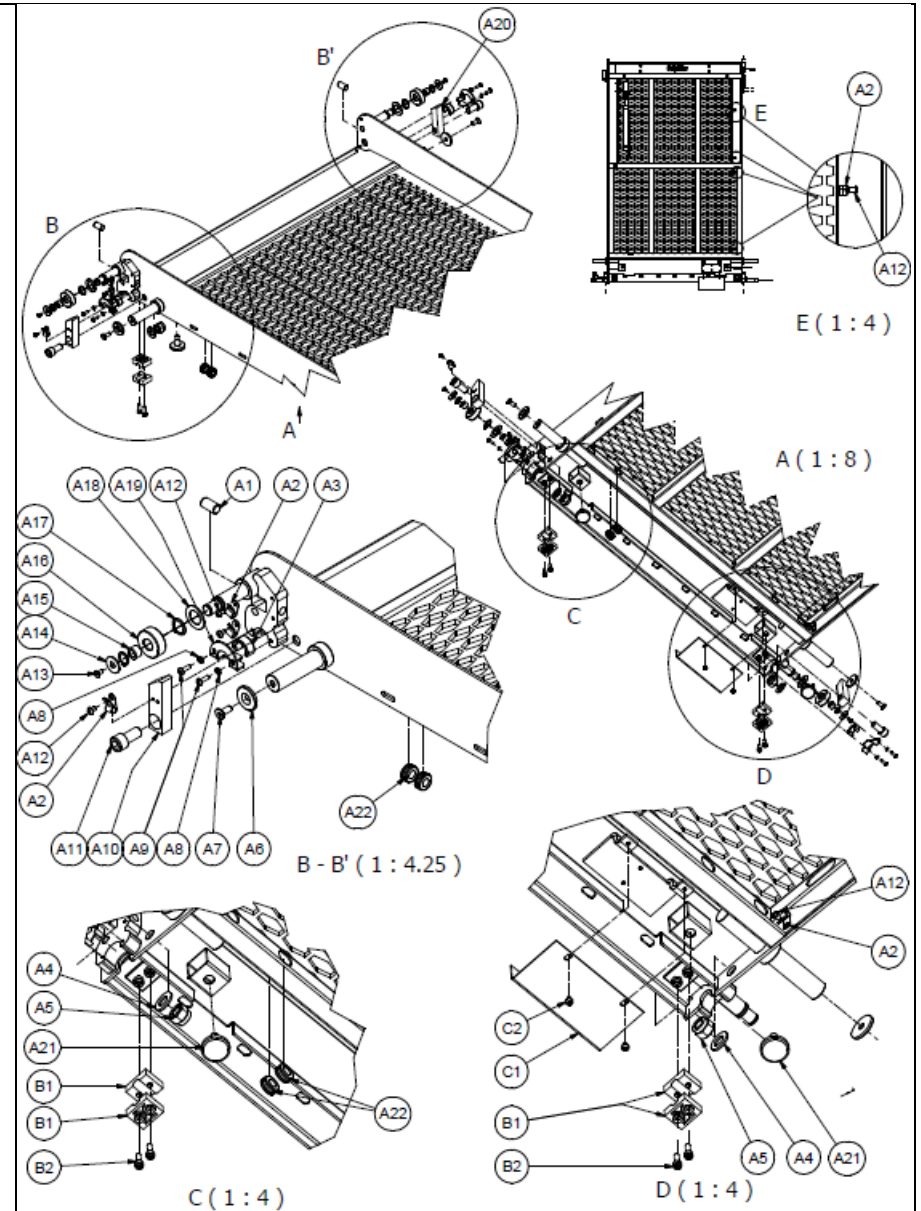



KIT2205 : FRONT FLAP SAFETY HOOK KIT				
Pos.	Quantity	Code	Description	NOTE
A1	1	502232	RING M12X1	
A2	1	BOC0262	BUSH	
A3	1	ASM1494	UNLOCK	
A4	1	MOL0066	SPRING	
A5	1	RON0031	WASHER Ø5	
A6	1	VIT0196	SCREW TCEI M5X10	

KIT2210 : STOWING PLATFORM BUFFER KIT				
Pos.	Quantity	Code	Description	NOTE
B1	2	PIA0664	BUFFER	
B2	4	#501743	SCREW TCEI M6X10	

KIT2215 : SWITCH FRONT FLAP 2 KIT				
Pos.	Quantity	Code	Description	NOTE
C1	1	CAB0183	SENSOR	
C2	1	LAS2011	SUPPORT	
C3	2	VIT0185	SCREW TBEI M5X8	
C4	2	RON0047	WASHER Ø3	
C5	2	VIT0209	SCREW TBEI M3X10	

KIT2220 : RUBBER BUFFER FLAP KIT				
Pos.	Quantity	Code	Description	NOTE
D1	3	DAD0035	NUT M8	
D2	3	RON0001	WASHER Ø8	
D3	2	#551025	M8 RUBBER STOP	

KIT2222 : MECHANISM COVER				
Pos.	Quantity	Code	Description	NOTE
E1	2	COP0097	MECHANISM COVER	
E2	2	RON0031	WASHER Ø5	
E3	2	VIT0185	SCREW TBEI M5X8	

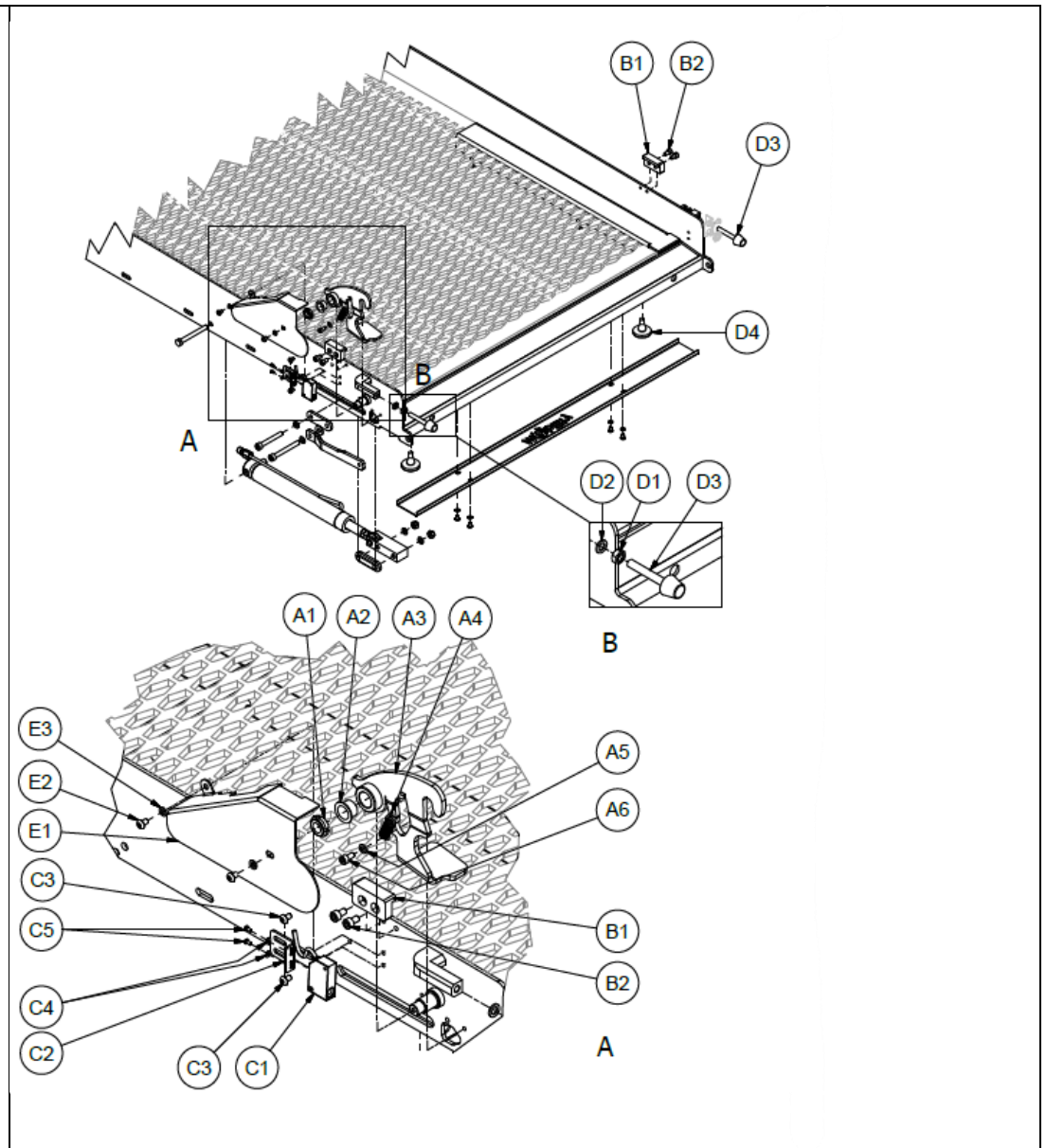



KIT2225 : SLIDING SYSTEM FRONT FLAP CYLINDER				
Pos.	Quantity	Code	Description	NOTE
A1	1	VIT0179	SCREW TE M8X75	
A2	2	PAT0067	SLIDING	
A3	1	BOC0082	BUSH	
A4	4	RON0001	WASHER Ø8	
A5	1	VIT0199	SCREW TCEI M8X60	
A6	1	501771	SCREW TCEI M8X70	
A7	1	LAS1983	LINKAGE	
A8	2	DAD0034	NUT M8	

KIT2230 : MOBILITY PLATFORM COVER KIT				
Pos.	Quantity	Code	Description	NOTE
B1	4	VIT0185	SCREW TBEI M5X8	
B2	4	RON0031	WASHER Ø5	
B3	1	LAS2022	COVER	

KIT2235 : SWITCH FRONT FLAP 1				
Pos.	Quantity	Code	Description	NOTE
C1	1	LAS2076	SUPPORT SENSOR	LEFT
C2	1	#550515	FIXING	
C3	1	VIT0185	SCREW TBEI M5X8	
C4	1	CON0110	SENSOR	

KIT2188 : FULL ASSEMBLY PLATFORM KIT				
Pos.	Quantity	Code	Description	NOTE
	1	KIT2205		
	1	KIT2210		
	1	KIT2215		
	1	KIT2220		
	1	KIT2222		
	1	KIT2190		
	1	KIT2195		
	1	KIT2200		
	1	KIT2225		
	1	KIT2230		
	1	KIT2235		
	1	ASM1490		

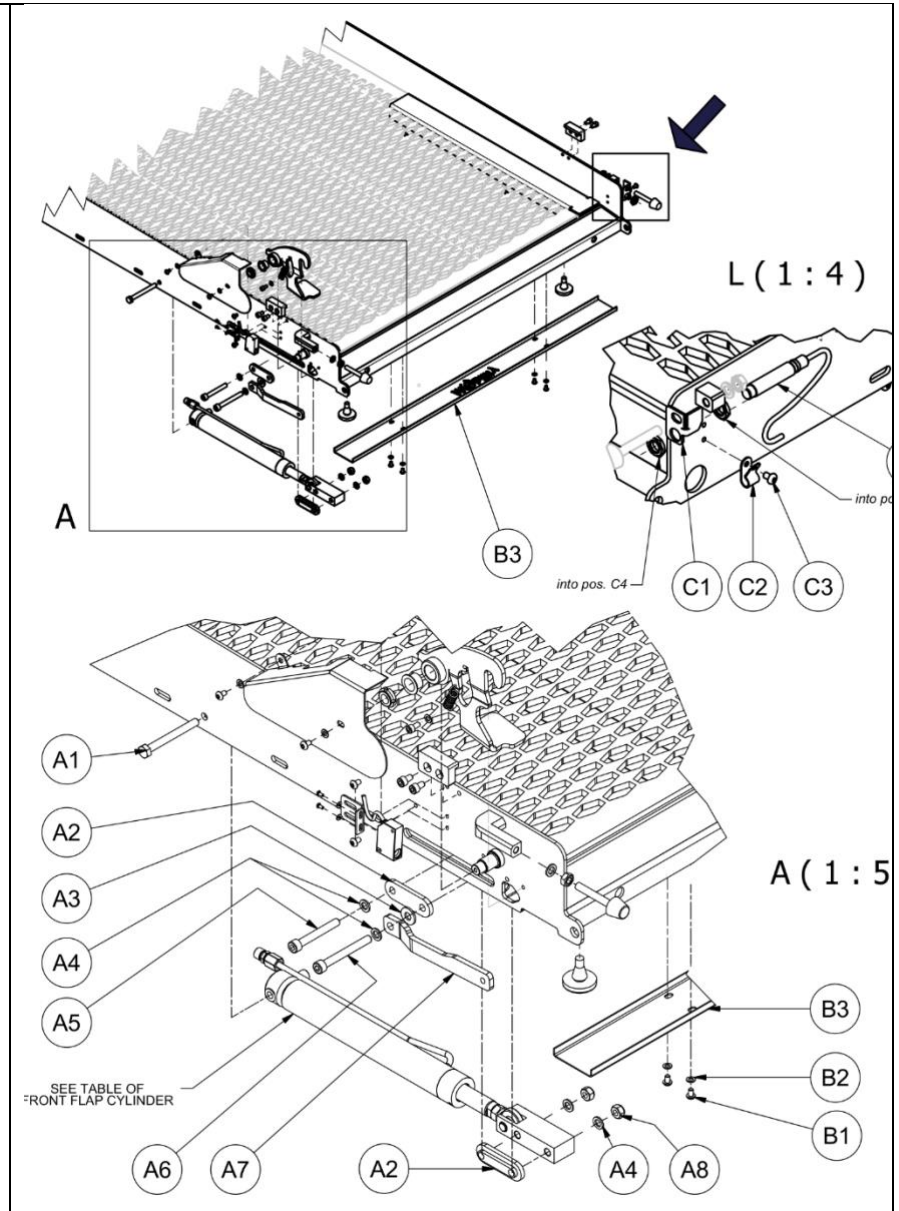

KIT2240 : ASSEMBLY FRONT FLAP KIT				
Pos.	Quantity	Code	Description	NOTE
	1	KIT2245	FRONT FLAP ALLOY AND RUBBER PROFILE KIT	
	1	KIT2250	FRONT FLAP LOCKING PIN KIT	
	1	KIT2255	MAIN FRAME FRONT FLAP KIT	

KIT2245 : FRONT FLAP ALLOY AND RUBBER PROFILE KIT				
Pos.	Quantity	Code	Description	NOTE
A1	1	PRF0464	RUBBER	
A2	1	PRF0463	OUTER BARRIER PROFILE	
A3	7	#502147	SCREW TSPEI M5X6	

KIT2250 : FRONT FLAP LOCKING PIN KIT				
Pos.	Quantity	Code	Description	NOTE
B1	1	ASM1510	BLOCK PIN	
B2	4	RON0002	WASHER Ø6	
B3	4	DAD0022	NUT M6	
B4	4	#551259	SCREW TSPEI M6X16	

KIT2255 : MAIN FRAME FRONT FLAP KIT				
Pos.	Quantity	Code	Description	NOTE
C1	2	BOC0021	BUSH	
C2	2	RON0039	WASHER Ø12	
C3	2	502470	NUT M10	
C4	2	VIT0187	SCREW TCEI M10X55	
C5	1	#E406065	PIN (M8)	
C6	1	BOC0035	BUSH	
C7	1	BOC0082	SPACER BUSH	
C8	1	DAD0042	NUT M8	
C9	1	ASM1491	OUTER BARRIER	

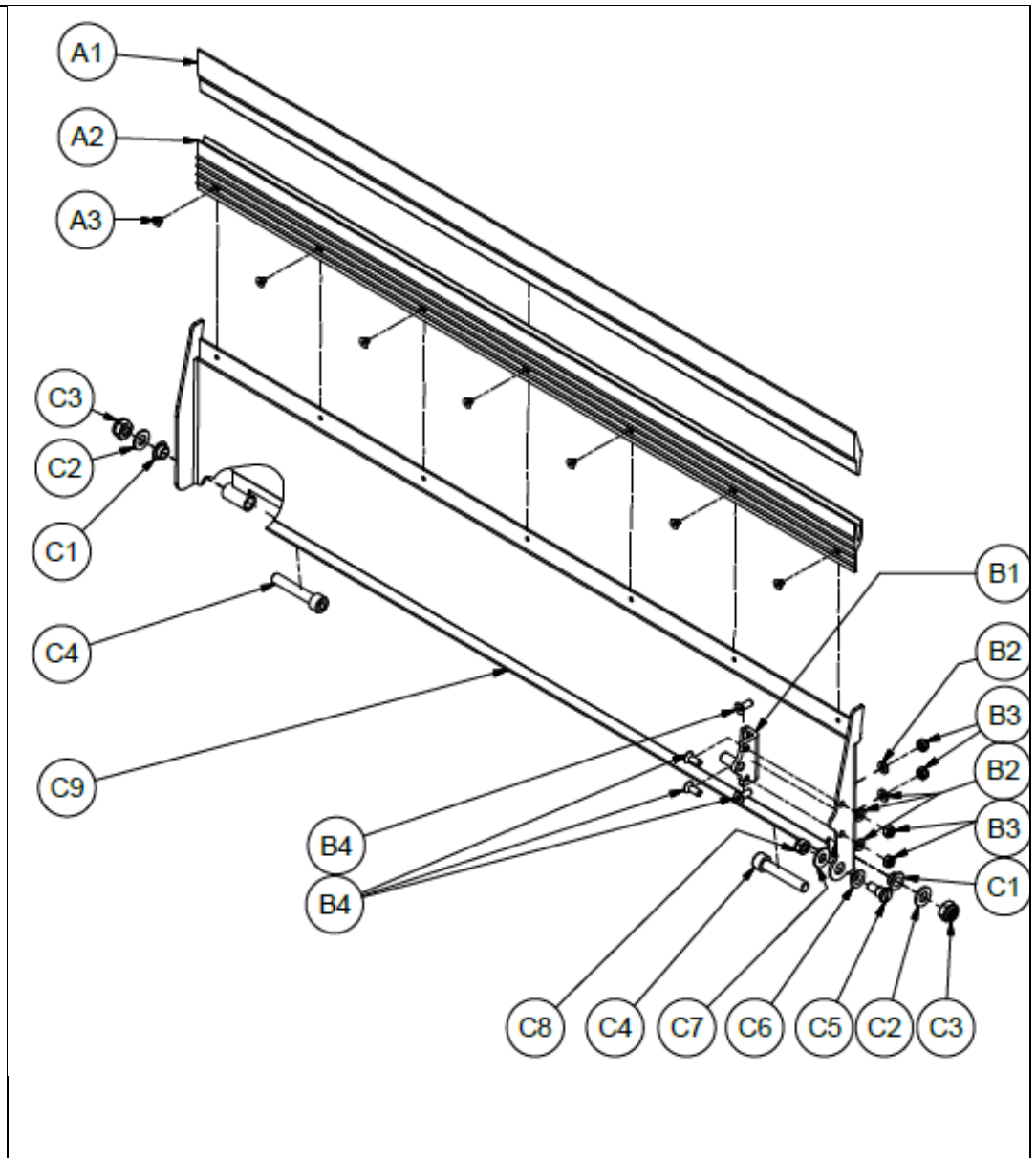

KIT2260 : PRESSURE SWITCH KIT				
Pos.	Quantity	Code	Description	NOTE
A1	1	550805	WASHER 1/4	
A2	1	#503104	FITTING 8-1/4	
A3	1	#550061	FITTING Ø8	
A4	1	550397	CUP 1/4	
A5	1	BLO0092	1/4 SUPPLY UNIT	
A6	1	INT0041	PRESSURE	
A7	1	INT0042	PRESSURE	
A8	1	#550205	WASHER 1/4	COPPER

KIT2265 : SUCTION TUBE KIT				
Pos.	Quantity	Code	Description	NOTE
B7	1	CID0106	HYDRAULIC UNIT	
B1	1	550805	WASHER 1/4	
B2	1	550355	FITTING 1/4-12	
B3	1	TID0282	HYDRAULIC PIPE	
B4	1	550024	FITTING 3/8-12	
B5	1	550759	WASHER 3/8	
B6	1	FIL0005	FILTER	

KIT2270 : OIL FILLING HOSE KIT				
Pos.	Quantity	Code	Description	NOTE
C1	1	TID0287	REFILL OIL	
C2	1	TAP0060	FILLER CUP	

KIT2275 : EXTERNAL HYDRAULIC FITTING KIT				
Pos.	Quantity	Code	Description	NOTE
D1	1	550805	WASHER 1/4	
D2	1	RAC0031	FITTING 1/4-1/8	
D3	1	RAC0018	FITTING 90°- Ø6-Ø6	
D4	1	TID0283	EXTENSION	
D5	1	RAC0051	FITTING T 06L	

KIT2280 : TANK KIT				
Pos.	Quantity	Code	Description	NOTE
E1	1	SER0012	TANK	1,5L
E2	1	TAP0052	OIL SIGHT GLASS	
E3	1	551242	FITTING 3/8-1/8	
E4	1	550278	FITTING 90° 1/8	
E5	1	550116	DRAIN PLUG	
E6	1	550759	WASHER 3/8	

KIT2282 : MANIFOLD KIT				
Pos.	Quantity	Code	Description	NOTE
F1	1	CID0106	HYDRAULIC PUMP	
F2	1	STRO015	RELIEF VALVE	

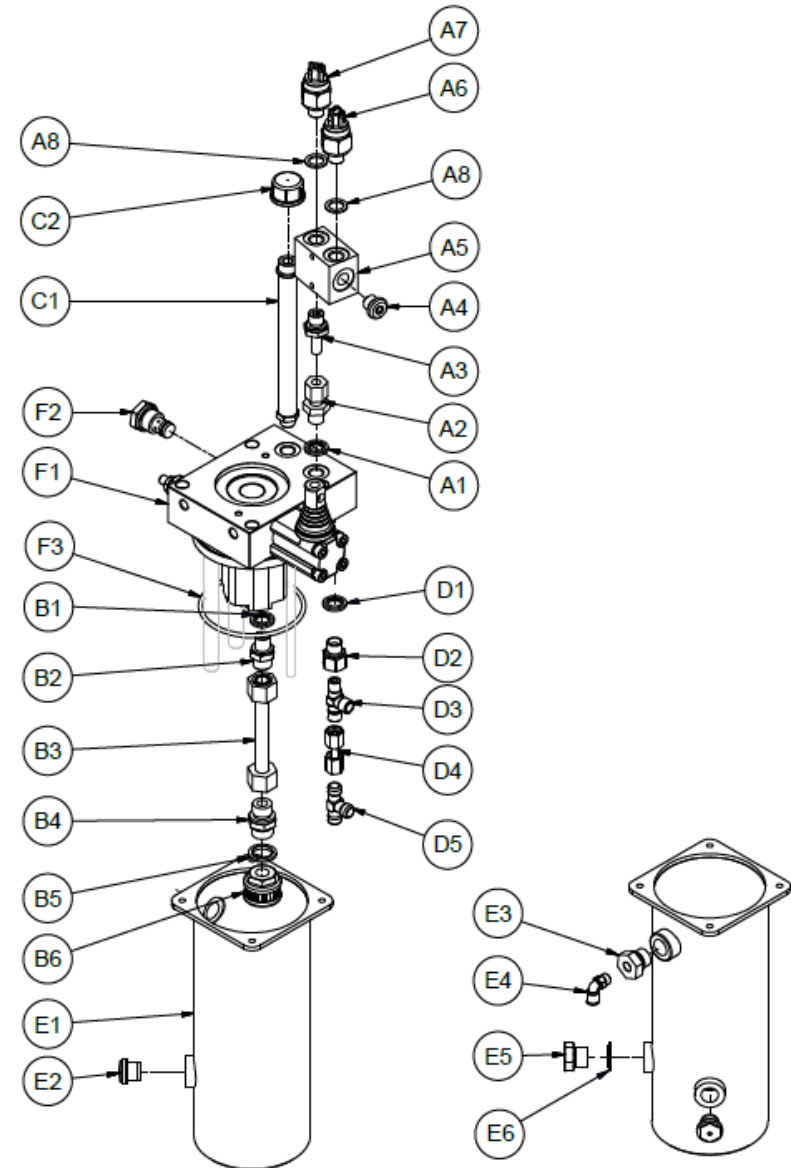

KIT2285 : ELECTRIC MOTOR KIT				
Pos.	Quantity	Code	Description	NOTE
A1	2	501479	WASHER Ø8	
A2	2	#501573	SCREW TCEI M8X16	
A4	1	#550741	ELECTRIC MOTOR	12V
A5	1	RELO001	START SOLENOID	12V
A6	1	DAD0020	STUD	
A7	1	VIT0103	HOSE CLAMP	
A8	2	KIT0043	ELECTRIC JUNCTION	
KIT2290 : HYDRAULIC UNIT MANIFOLD FIXING KIT				
Pos.	Quantity	Code	Description	NOTE
B1	2	501367	WASHER Ø10	
B2	2	501480	WASHER Ø10	
B3	2	500456	SCREW M10X16	
KIT2295 : FIXING KIT FOR BLACK PLATE POWER PACK				
Pos.	Quantity	Code	Description	NOTE
C1	3	TUB0097	SPACER	
C2	3	501763	SCREW TCEI M8X30	
C3	1	PAS0001	RUBBER GROMMET	
KIT2300 : COVER KIT AND FIXINGS				
Pos.	Quantity	Code	Description	NOTE
D1	6	FIX0011	FAST TURN FIX	
D2	6	VIT0119	FAST TURN PIN	
D3	1	LAS1777	COVER	RIGHT
	1	LAS2078	COVER	LEFT
KIT2305 : LOWERING VALVE KIT				
Pos.	Quantity	Code	Description	NOTE
E1	1	#550334	DOWN VALVE	
E2	1	550519	DOWN COIL	
E3	1	TON0077	DOWN VALVE HANDLE	
KIT2310 : HAND PUMP ROD KIT				
Pos.	Quantity	Code	Description	NOTE
F1	1	#552358	HANDLE SUPPORT	
F2	1	MAN0013	HANDLE SUPPORT	
F3	1	GUA0053	O-RING	
KIT2315 : LCD DISPLAY KIT				
Pos.	Quantity	Code	Description	NOTE
G1	1	COP0092	LCD SCREEN MOUNT	
G2	1	SCH0067	SCREEN	
KIT2355 : POWER PACK KIT				
Pos.	Quantity	Code	Description	NOTE
I1	1	CAB0198	WARNING LIGHT	
L1	1	LAS1953	SUPPORT	RIGHT
	1	LAS2077	SUPPORT	LEFT
N1	1	CAB0201	BUZZER	
M1	1	KIT2282	PUMP	
P1	1	KIT2280	TANK	
KIT2355 : POWER PACK KIT				
Pos.	Quantity	Code	Description	NOTE
A(1...8)	1	KIT2285	ELECTRIC MOTOR KIT	
B(1...4)	1	KIT2290	HYDRAULIC UNIT MANIFOLD FIXING KIT	
E(1...3)	1	KIT2305	LOWERING VALVE KIT	
M1	1	KIT2282	HYDRAULIC PUMP	
P1	1	KIT2280	TANK	

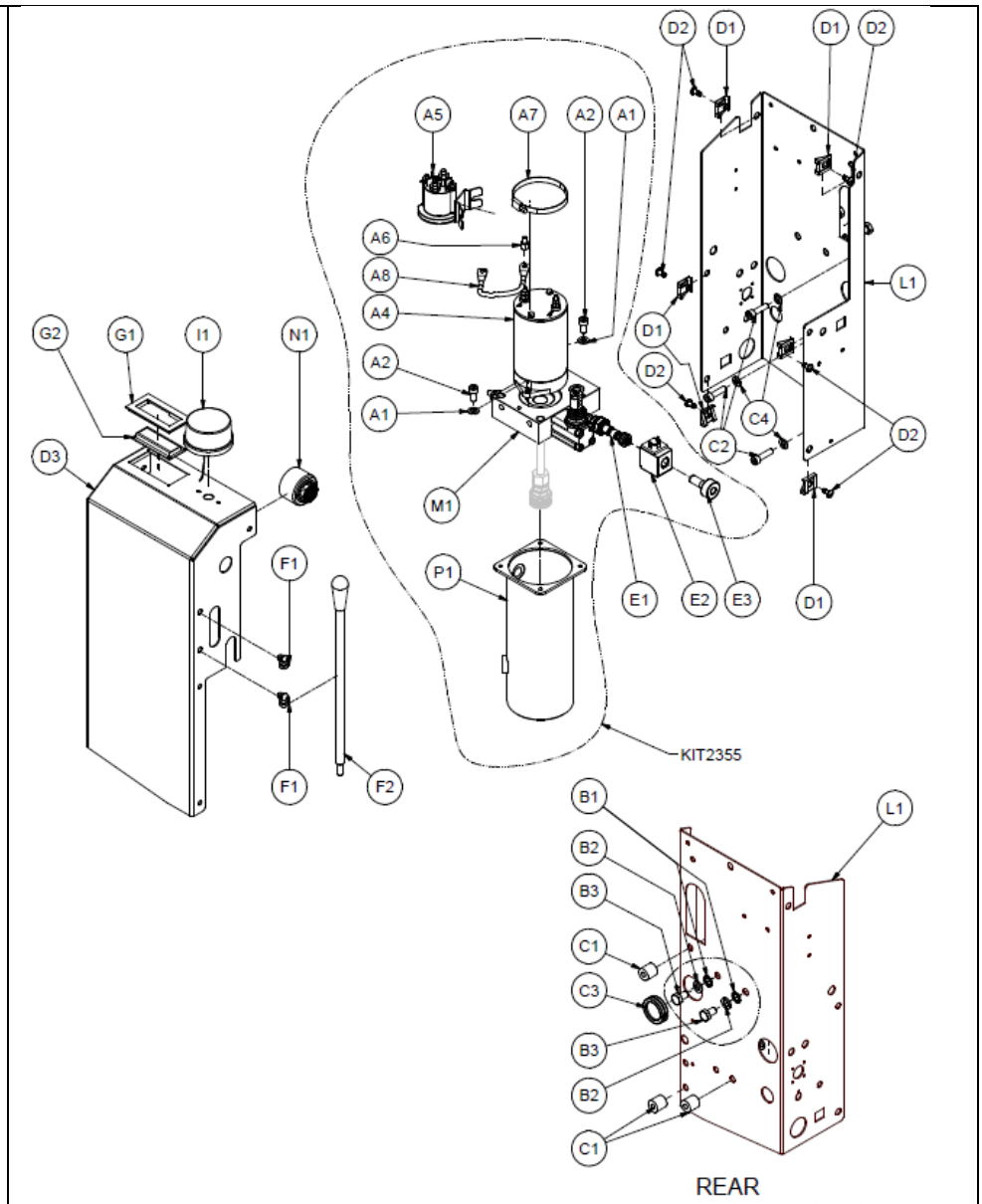

KIT2320 : EARTHING BOLT KIT				
Pos.	Quantity	Code	Description	NOTE
A1	1	VIT0190	SCREW TE M8X35	BRASS
A2	4	RON0045	WASHER Ø8	BRASS
A3	2	DAD0037	NUT M8	BRASS

KIT2325 : ROTARY SENSOR KIT				
Pos.	Quantity	Code	Description	NOTE
B1	1	SENO014	ANGULAR SENSOR	
B2	1	SENO012	MAGNET	
B3	1	LAS1780	CAM	
B4	1	LAS1779	SUPPORT	
B5	1	#501941	GRUB M5X8	
B8	1	TAP0040	MAGNET CAP	
B9	2	501203	SCREW TCC M4X16	
B10	2	#501135	NUT M4	
B11	2	VIT0185	SCREW TBEI M5X8	

KIT2330 : ISOLATOR SOLENOID KIT				
Pos.	Quantity	Code	Description	NOTE
C1	2	501137	NUT M5	
C2	2	501476	WASHER Ø5	
C3	1	RELO007	ISOLATOR SOLENOID	14V
C4	2	RON0005	WASHER Ø5 LARGE	
C5	2	VIT0026	SCREW TE M5X14	

KIT2335 : ECU KIT				
Pos.	Quantity	Code	Description	NOTE
D1	1	GPP0694165	ECU COMPLETE KIT	
D2	3	501200	SCREW TCI M4X10	
D3	3	#551759	WASHER Ø4	

KIT2340 : RESETTABLE CIRCUIT BRAKERS KT				
Pos.	Quantity	Code	Description	NOTE
E1	1	FUS0002	RESETTABLE FUSE	8A
E2	1	FUS0001	RESETTABLE FUSE	30A
E3	1	FUS0004	RESETTABLE FUSE	5A

KIT2345 : HAND CONTROLLER KIT				
Pos.	Quantity	Code	Description	NOTE
F1	1	#C400630	HAND SUPPORT	
F2	1	PUL0049	HAND CONTROL	
F3	2	#551162	SCREW TSPEI M4X12	
F4	2	DAD0031	NUT M4	
F5	2	RON0032	WASHER Ø4	

Pos.	Quantity	Code	Description	NOTE
G1	1	INT0038	POWER SWITCH	
H1	1	CON0100	BATTERY THROUGH PANEL	

KIT2350 : ADAPTER FLANGE DOOR OPEN CONNECTOR				
Pos.	Quantity	Code	Description	NOTE
L1	1	LAS2159	SUPPORT OPEN DOOR	
L2	2	#501162	SCREW TBC M4X12	

Pos.	Quantity	Code	Description	NOTE
M1	1	LAS1953	Main plate for power pack	RIGHT
	1	LAS2077		LEFT



Lift Installation and Maintenance must be performed by an approved engineer.  
 Non-compliance may result in serious personal injury, damage to the vehicle and may affect or even void the product warranty.

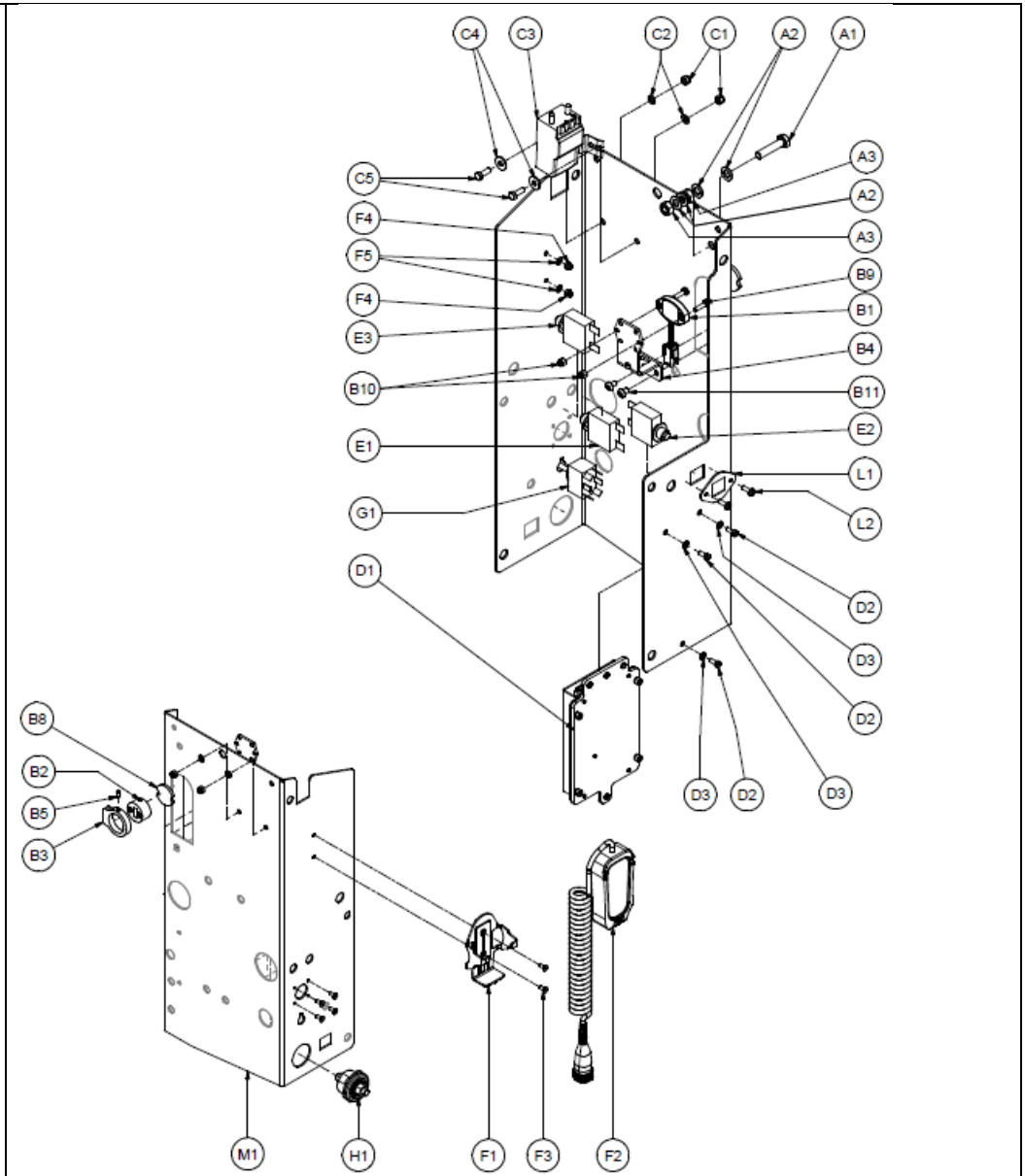

KIT2360 : HYDRAULIC HOSES KIT				
Pos.	Quantity	Code	Description	NOTE
A1	1	TID0275	FLEX PIPE ON BASE	
A2	1	TID0261	FLEX PIPE CYLINDER RIGHT	
A3	1	TID0262	FLEX PIPE CYLINDER LEFT	
A4	1	TID0277	TO CYLINDER OF PLATFORM	
A5	1	TID0276	FLEX PIPE ON VERTICAL ARM	
A6	1	TID0259	PIPE ON UPPER ARM	
A7	1	TID0263	PIPE ON VERTICAL ARM	

Pos.	Quantity	Code	Description	NOTE
B1	4	#503103	FITTING	

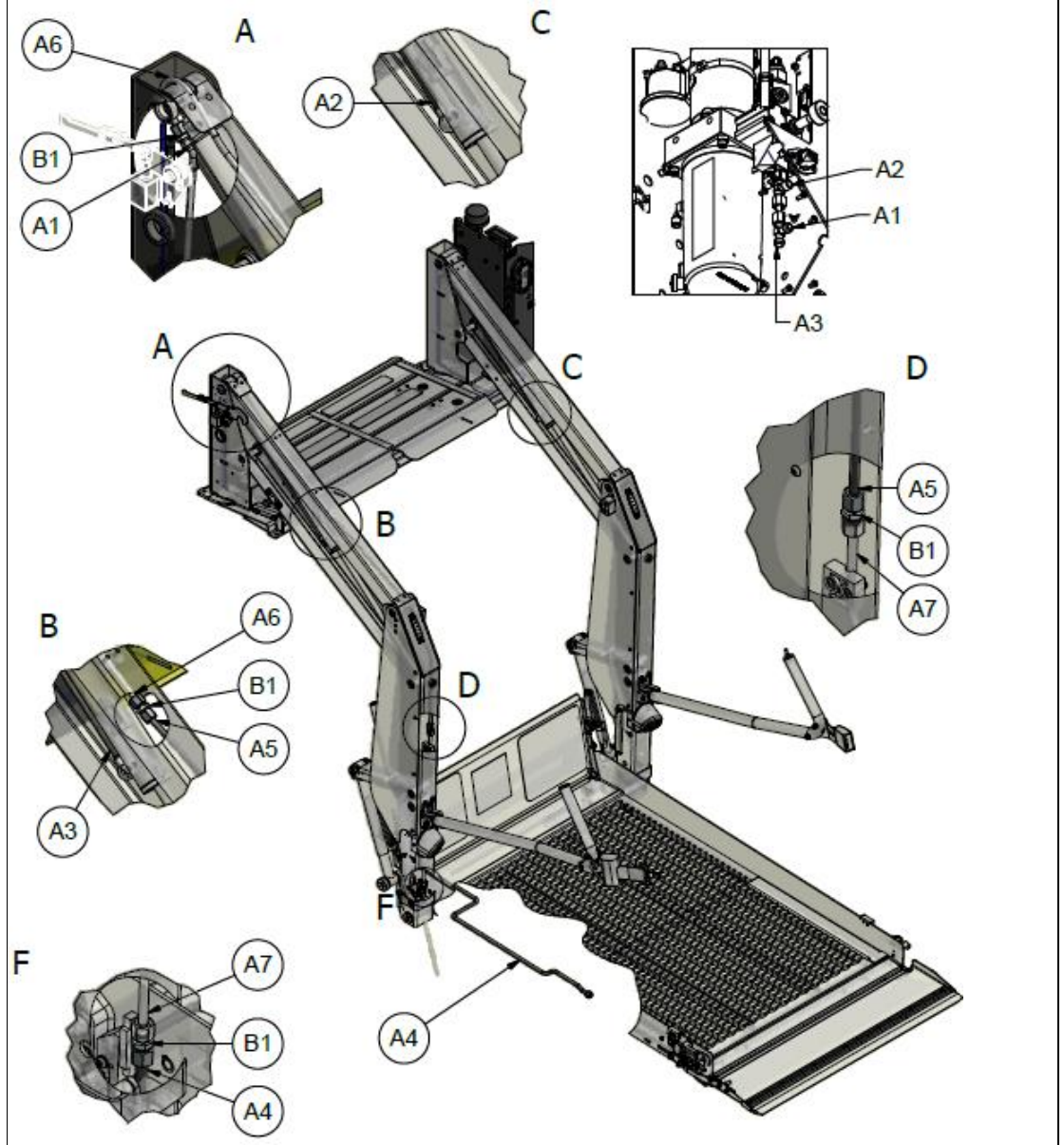

KIT2365 : HYDRAULIC BREATHER HOSE KIT				
Pos.	Quantity	Code	Description	NOTE
A1	1	#E551342	FITTING	
A2	MT. 0,3	550255	RETURN HOSE	
A3	MT. 0,8	550255	RETURN HOSE	
A3	MT. 1,6	550255	RETURN HOSE	

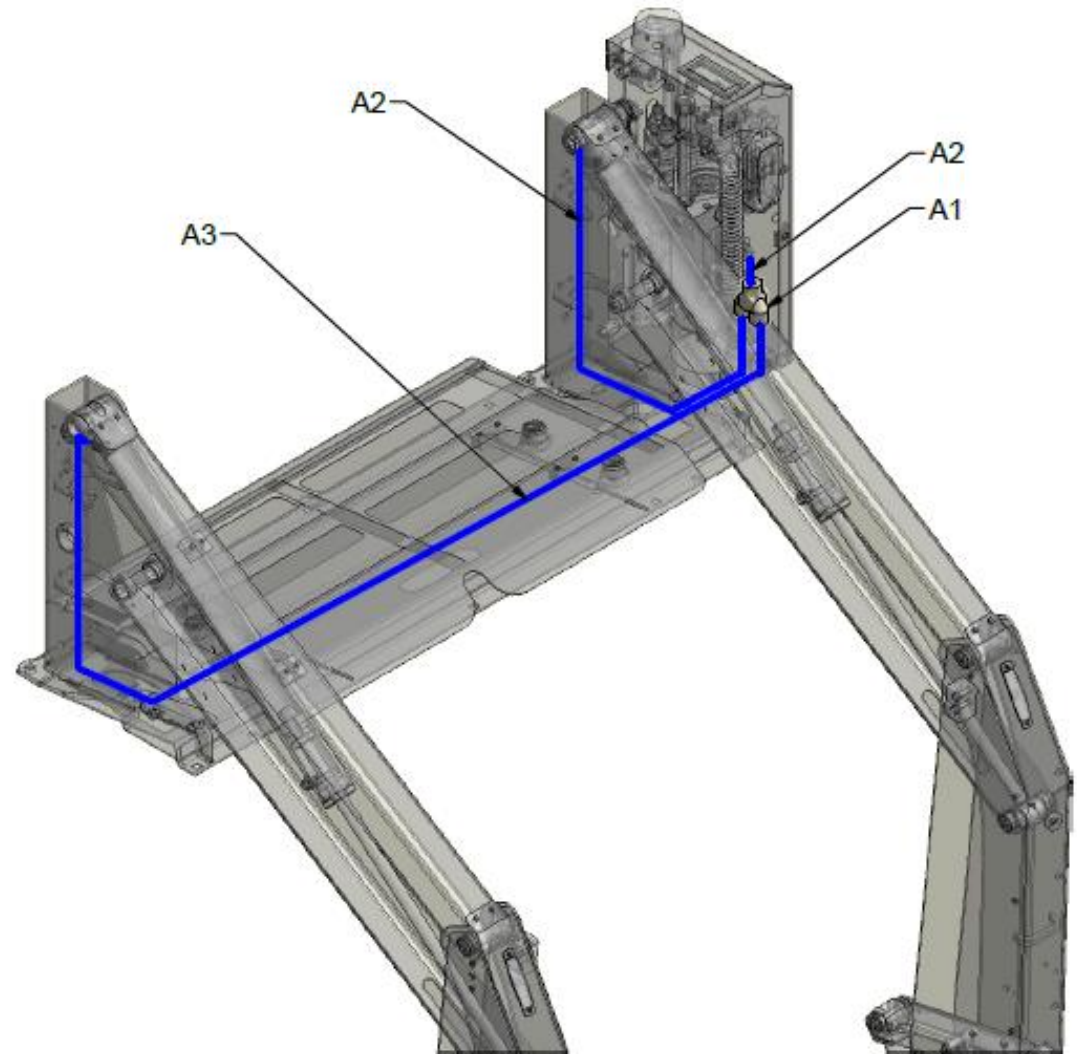

KIT2370 : PUBLIC HANDRAILS				
Pos.	Quantity	Code	Description	NOTE
A1	1	ASM1517	LEFT HANDRAIL	
A2	1	ASM1518	RIGHT HANDRAIL	
A3	2	TAP0059	CAP	

KIT2375 : PRIVATE HANDRAILS				
Pos.	Quantity	Code	Description	NOTE
B1	2	ASM1586	HANDRAIL	
B2	2	TAP0059	CAP	

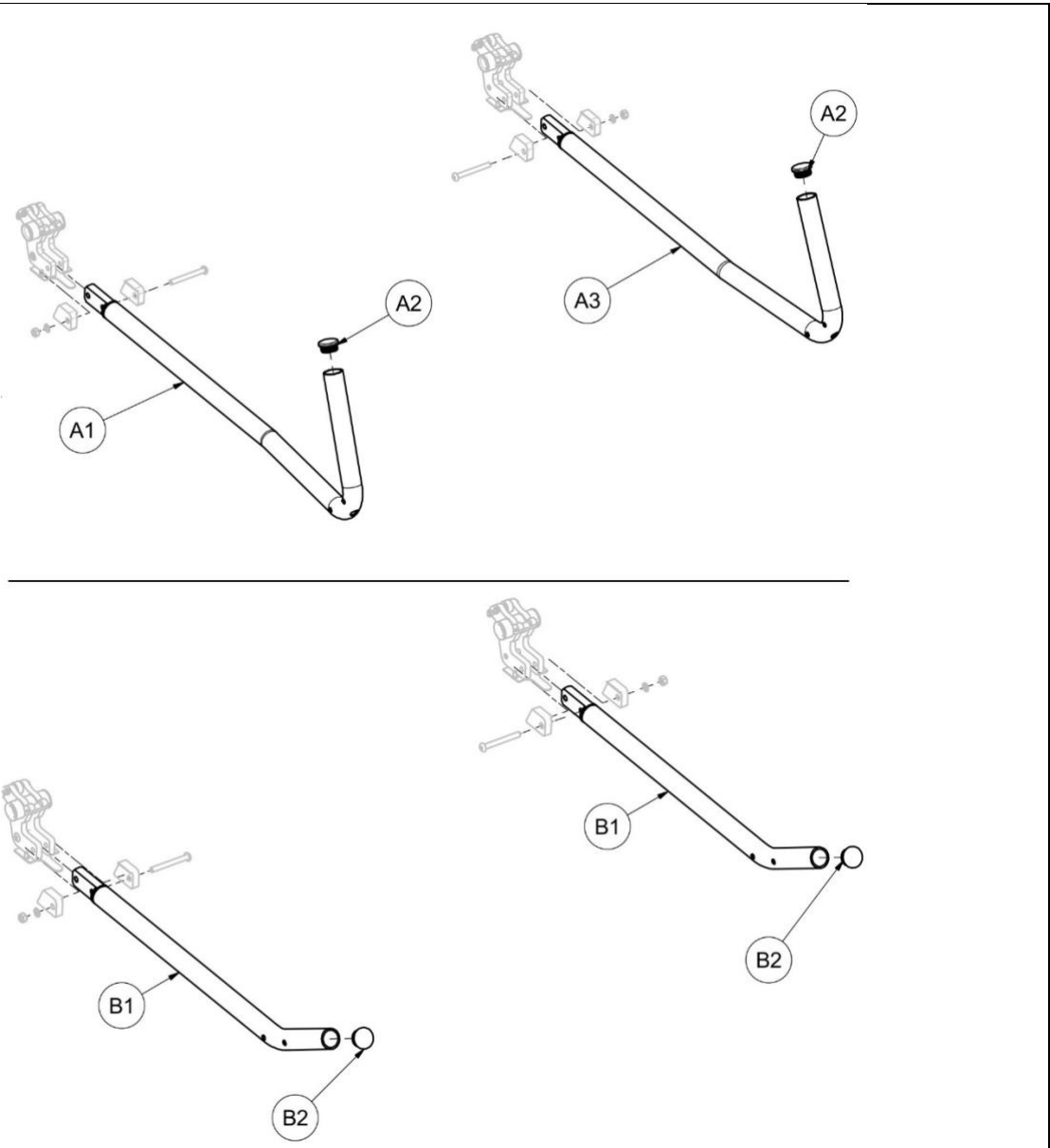



KIT2380 : SWITCH JOYSTICK KIT				
Pos.	Quantity	Code	Description	NOTE
A1	1	INT0008	SWITCH HANDRAIL	PRIVATE LIFTS ONLY
A2	1	TAP0008	CAP	

KIT2390 : SUPPORT SAFETY BELT KIT				
Pos.	Quantity	Code	Description	NOTE
B1	1	LAS2178	SUPPORT	
B2	1	VIT0208	SCREW TBEI M8X50	
B3	8	RON001	WASHER D.8	
B4	4	DAD0034	NUT M8	
B5	1	LAS2037	LEFT SUPPORT	

KIT2390 : SAFETY BELT KIT				
Pos.	Quantity	Code	Description	NOTE
C1	1	ACC0002	SAFETY BELT	
C2	1	ACC0003	SAFETY BELT BUCKLE	
C3	2	VIT0211	SCREW	
C4	4	RON0054	WASHER	
C5	2	DRD0043	NUT	
C6	1	CAB0194	CONNECTION HARNESS	

KIT2395 : SWITCH JOYSTICK AND SAFETY BELT				
Pos.	Quantity	Code	Description	NOTE
		KIT2380	SWITCH JOYSTICK	
		KIT2385	SUPPORT SAFETY BELT	
		KIT2390	SAFETY BELT	

