

RPB 35.11 RANGE OF CASSETTE LIFTS PUBLIC MOBILITY



RPB 35.11 RANGE OF CASSETTE LIFTS FOR HIGH FLOOR BUSES

THE PERFECT LIFTS FOR SMALL SPACES



Versatile and cost-effective.

- ✓ Compact and flat
- ✓ Integration with high-floor buses and coaches
- ✓ Anti-collision sensors and other safety features
- ✓ Several models and platform sizes for different applications

RPB 35.11 & HDI Cassette Lift safety compliance.

- ✓ SWL and CE certificates issued
- ✓ LOLER Installation Compliance
- ✓ Fully PSVAR, DDA, COIF, SVTA and BS6109 Part 2 compliant
- ✓ Meets ECWVTA (European Whole Vehicle Type Approval)
- ✓ ISO accredited production

ISO
9001

EMC
2014/30/EU

CE
2006/42/EC

RPB 35.11 RANGE OF CASSETTE LIFTS FOR HIGH FLOOR BUSES

PRODUCT HIGHLIGHTS

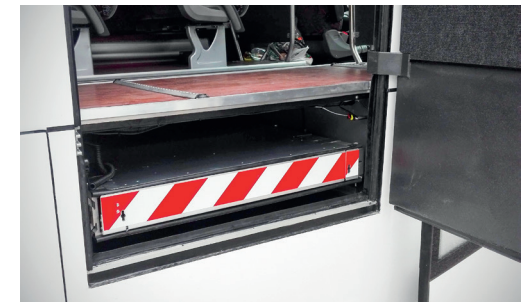
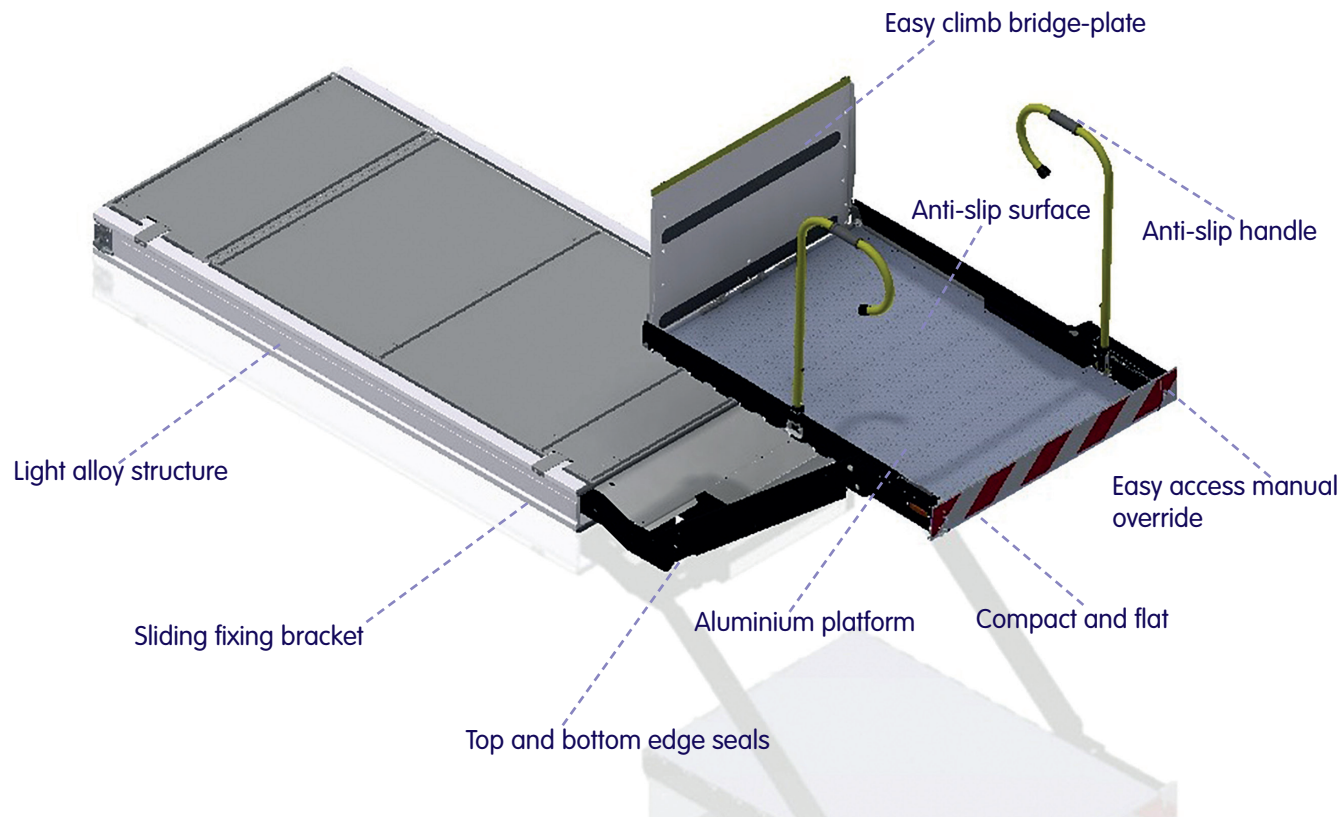

RPB 35.11 RANGE OF CASSETTE LIFTS FOR HIGH FLOOR BUSES

TECHNICAL DATA & OPTIONAL FEATURES

RPB 35.11 & HDI	Technical Data	Benefits
Platform size	802mm (w) x 1212/1312mm (l)	Fully-automatic
Cassette size	1026mm (w) x 1955/2055/2355mm (l) x 145mm (d)	Compact and flat cassette
Max. lifting height	900/1100/1250mm (HDI) (Ground to vehicle floor)	Compatible with any step height and vehicles
Lift standard weight	250kg (35.11) 263kg (HDI) 285kg (HD)	Built with high resistance aluminium
Lifting capacity (SWL)	300kg (HD) 400kg	Fit & Plug - Quick & easy installation
Voltage	24V	Various models and platform sizes



Remote Control

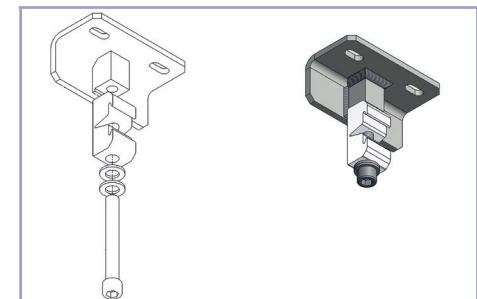

Fitting Brackets



SCAN TO EXPERIENCE THE RPB 35.11 & HDI

CASSETTE LIFT DIMENSIONS (MM)							
Lift Model	Height (Max)	Lower (Max.)	Length	Width	Height	Platform	Platform Width
RPB 35.11 (Step Compartment)	901	489	1955	1090	145	1212	802
RPB 35.11 HD (Coaches)	1093	549	2250	1026	145	1212	802
RPB 35.11 HDI (Coaches)	445	910	2055	1026	145	1212	802
RPB 35.11 HDH (High Deck)	750	1330	2315	1139	200	1312	802

RPB 35.11 RANGE OF CASSETTE LIFTS FOR HIGH FLOOR BUSES

OPTIONAL FEATURES & TECHNICAL DRAWINGS

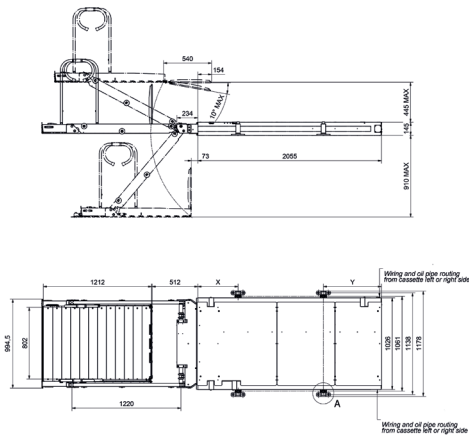

RPB 35.11 HDI Dimensions in mm

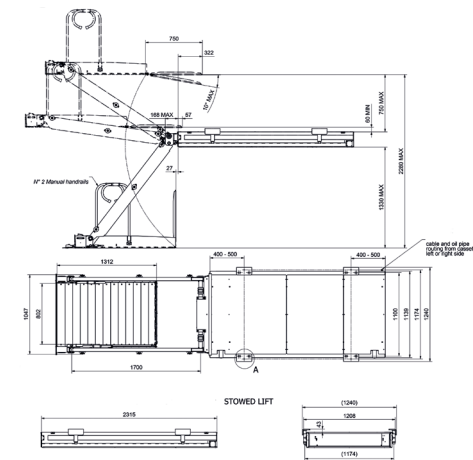

RPB 35.11 HDH Dimensions in mm

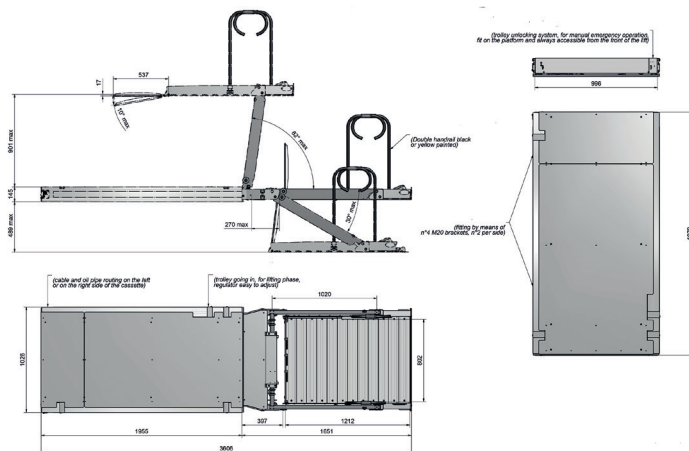

RPB 35.11 Dimensions in mm

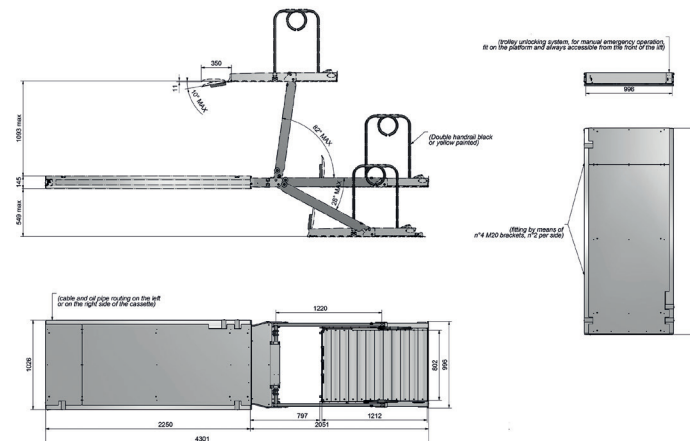

RPB 35.11 HD Dimensions in mm

COMPANY OVERVIEW

The Mobility Networks Group is a leading multi-national specialist in vehicle accessibility products. Our key mobility brands have been established for over 25 years with a continually expanding portfolio of vehicle access lifts, ramps, steps, seats, flooring and lowered floor conversion kits for all budgets and technical requirements.



CONTACT

12 Estuary View Business Park
Whitstable | Kent | CT5 3SE
United Kingdom

www.mobilitynetworksgroup.com

info@mobilitynetworksgroup.com

T+ 44 (0) 1227 505022
F + 44 (0) 1227 505023

OUR HISTORY



- 2014 THE MOBILITY NETWORKS GROUP IS ESTABLISHED IN THE UK
Rapidly expanding its operations internationally and acquiring new brands.
- 2004 ACDEOS BV IS FOUNDED IN THE NETHERLANDS
Creating a wide European network of distributors for its range of ramps and steps.
- 1995 CAROIL SYSTEM SRL IS ESTABLISHED IN ITALY
Becoming one of the leading European lift manufacturers.
- 1990 PLS (PASSENGER LIFT SERVICES) IS FOUNDED IN THE UK
Becoming a market leader in wide range of cassette lifts.

ACHIEVEMENTS



- ACDEOS MERGER 2017
- THE WIDEST MOBILITY RANGE 2017
- LEADER IN CASSETTE LIFTS 2017
- LEADER IN COACH LIFTS 2017
- CAROIL MERGER 2015
- PLS MERGER 2014

THE MOBILITY WORLD

VISION & PURPOSE

"MOBILITY NETWORKS CREATE AND PRODUCE EQUIPMENT THAT FACILITATES AND SUPPORTS INDIVIDUALS TO GAIN GREATER FREEDOM"

We achieve this by being a dependable partner to OEMs and Converters, offering the right products from basic to premium to our customers and distribution partners around the world.

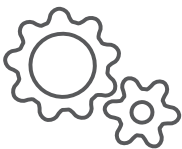

FIGURES

DOUBLE DIGIT GROWTH
50,000 + LIFTS SOLD
130 + EMPLOYEES
100S OF PRODUCTS



LOCATIONS

- Mobility Networks - Global Headquarters
Whitstable, Kent, United Kingdom
- PLS (Passenger Lift Services)
Smethwick, Birmingham, United Kingdom
- Caroil System
Palidano di Gonzaga, (Mn), Italy
- Acdeos BV
Touwbaan, Leiderdorp, The Netherlands
- Mobility Networks Offices
Canada, Denmark, Romania



BRANDS

MOBILITY NETWORKS
PLS (PASSENGER LIFTS SERVICES)
CAROIL SYSTEM
ACDEOS

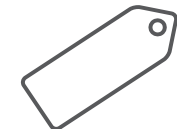

HELPING YOU MAKE INFORMED DECISIONS

Our Smart Range was created to promote the differences between each product group and help our customers make informed purchasing decisions. Visit our webpage to find out more about the Smart Premium, Smart + and Smart Basic product range.

