

# CONCEALED CASSETTE LIFT PUBLIC MOBILITY

**Mobility**  
NETWORKS  
VEHICLE ACCESSIBILITY SOLUTIONS



# CONCEALED CASSETTE LIFT FOR MINI BUSES

## A UNIQUE SOLUTION TO ALL MINIBUSES



The Concealed Cassette Lift combines aesthetics, hidden within the vehicle floor, whilst avoiding ground clearance issues.

- ✓ Longer length platform (1410-1740mm)
- ✓ It does not affect ground clearance (minibuses can drive over multiple speed humps or across uneven surfaces)
- ✓ The Lite version operates with 30% less hydraulic pressure than other models, saving battery power when loading
- ✓ **Smart Design** with cutting edge materials, 50kg lighter
- ✓ Standard anti-vibration features

# CONCEALED CASSETTE LIFT FOR MINI BUSES

## PRODUCT HIGHLIGHTS

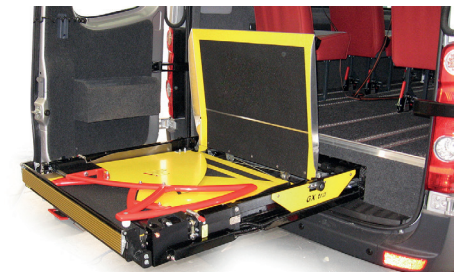
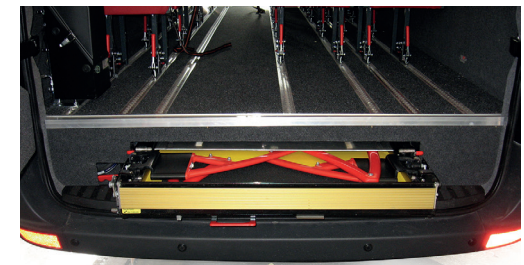
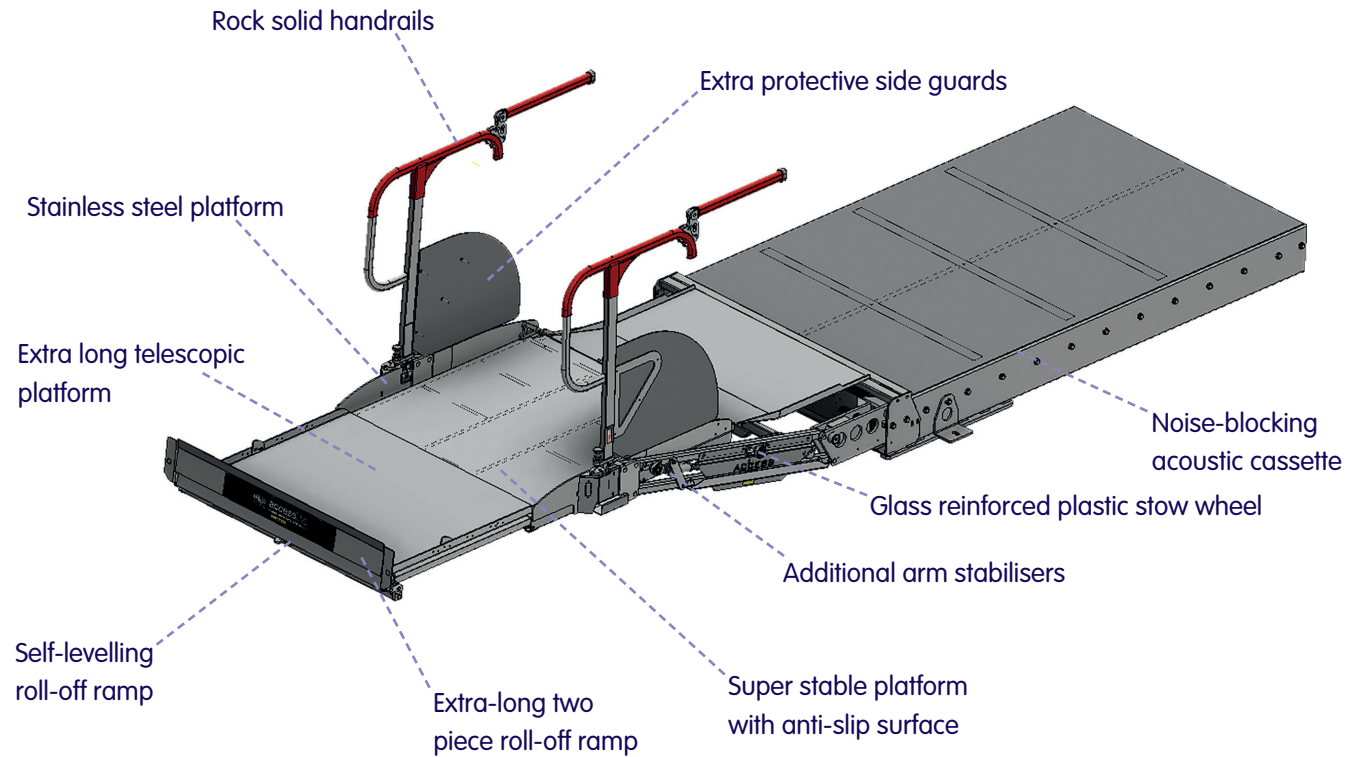

# CONCEALED CASSETTE LIFT FOR MINI BUSES

## TECHNICAL DATA

| CONCEALED CASSETTE   | Technical Data                      | Benefits                                 |
|----------------------|-------------------------------------|------------------------------------------|
| Platform usable size | 825mm (w) x 1405mm (l)              | Fully-automatic or manual                |
| Cassette size        | 1000mm (w) x 1700mm (l) x 175mm (d) | Saves internal vehicle space             |
| Max lifting height   | 1150mm (ground to vehicle floor)    | Twin red rubber coated handrails         |
| Lifting capacity SWL | 300kg                               | Compatible with all mini-bus types       |
| Standard weight      | 235kg                               | Manual override with emergency hand pump |

- Concealed Cassette Lift safety compliance.
- ✓ SWL and CE certificates issued
  - ✓ LOLER Installation Compliance
  - ✓ Fully PSVAR, DDA, COIF, SVTA and BS6109 Part 2 compliant
  - ✓ Meets ECWVTA (European Whole Vehicle Type Approval)
  - ✓ ISO accredited production



SCAN TO EXPERIENCE THE CONCEALED LIFT

# CONCEALED CASSETTE LIFT FOR MINI BUSES

## OPTIONAL FEATURES

### Concealed Cassette Lift options.

- ✓ Lifting capability upgrades
- ✓ Flashing or static LED warning lights
- ✓ Stainless steel anti-corrosion package
- ✓ Manual handrail/platform options available
- ✓ 2 x remote controllers that include illumination and or wireless operation
- ✓ Flush mounted door control option
- ✓ Box micro fitted to enable a correct stowage signal
- ✓ Additional handsets



FLASHING LIGHTS

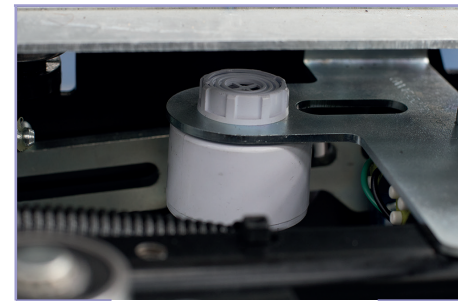

AUDIBLE WARNING DEVICE

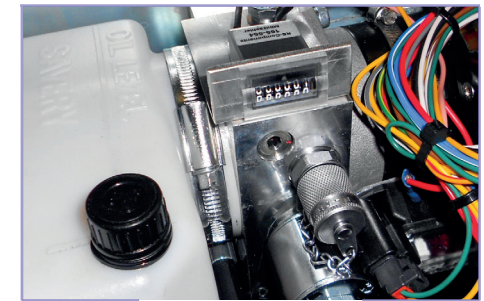

CYCLE COUNTER



EXTENDABLE HANDRAILS



DOOR SAFE II



A STOP SAFE ULTRA

ISO  
9001

EMC  
2014/30/EU

CE  
2006/42/EC

## CONTACT

12 Estuary View Business Park  
Whitstable | Kent | CT5 3SE  
United Kingdom

www.mobilitynetworksgroup.com

info@mobilitynetworksgroup.com

T+ 44 (0) 1227 505022  
F + 44 (0) 1227 505023

## COMPANY OVERVIEW

The Mobility Networks Group is a leading multi-national specialist in vehicle accessibility products. Our key mobility brands have been established for over 25 years with a continually expanding portfolio of vehicle access lifts, ramps, steps, seats, flooring and lowered floor conversion kits for all budgets and technical requirements.



## OUR HISTORY

- 2014 THE MOBILITY NETWORKS GROUP IS ESTABLISHED IN THE UK  
Rapidly expanding its operations internationally and acquiring new brands.
- 2004 ACDEOS BV IS FOUNDED IN THE NETHERLANDS  
Creating a wide European network of distributors for its range of ramps and steps.
- 1995 CAROIL SYSTEM SRL IS ESTABLISHED IN ITALY  
Becoming one of the leading European lift manufacturers.
- 1990 PLS (PASSENGER LIFT SERVICES) IS FOUNDED IN THE UK  
Becoming a market leader in wide range of cassette lifts.

## ACHIEVEMENTS

- ACDEOS MERGER 2017
- THE WIDEST MOBILITY RANGE 2017
- LEADER IN CASSETTE LIFTS 2017
- LEADER IN COACH LIFTS 2017
- CAROIL MERGER 2015
- PLS MERGER 2014

# THE MOBILITY WORLD

## VISION & PURPOSE

**"MOBILITY NETWORKS CREATE AND PRODUCE EQUIPMENT THAT FACILITATES AND SUPPORTS INDIVIDUALS TO GAIN GREATER FREEDOM"**

We achieve this by being a dependable partner to OEMs and Converters, offering the right products from basic to premium to our customers and distribution partners around the world.

## FIGURES

DOUBLE DIGIT GROWTH

50,000 + LIFTS SOLD

130 + EMPLOYEES

100S OF PRODUCTS

## LOCATIONS

- Mobility Networks - Global Headquarters  
Whitstable, Kent, United Kingdom
- PLS (Passenger Lift Services)  
Smethwick, Birmingham, United Kingdom
- Caroil System  
Palidano di Gonzaga, (Mn), Italy
- Acdeos BV  
Touwbaan, Leiderdorp, The Netherlands
- Mobility Networks Offices  
Canada, Denmark, Romania

## BRANDS

MOBILITY NETWORKS

PLS (PASSENGER LIFTS SERVICES)

CAROIL SYSTEM

ACDEOS

HELPING YOU MAKE INFORMED DECISIONS

- Our Smart Range was created to promote the differences between each product group and help our customers make informed purchasing decisions. Visit our webpage to find out more about the Smart Premium, Smart + and Smart Basic product range.

