

# ACCESS™ STEP-WELL CASSETTE PUBLIC MOBILITY



# ACCESS™ STEP-WELL CASSETTE LIFT FOR HIGH FLOOR BUSES

## WITH AN EXCLUSIVE TELESCOPIC PLATFORM



Proven technology compatible with most high-floor bus designs.

- ✓ Deployed in only 60 seconds
- ✓ Concealed for improved aesthetics
- ✓ Allows for more internal space
- ✓ Broadest range of options and platform sizes
- ✓ Stable platform with anti-vibration features
- ✓ Several safety and optional features
- ✓ Compatible with most high floor city bus designs
- ✓ No compromise on vehicle ground clearance

# ACCESS™ STEP-WELL CASSETTE LIFT FOR HIGH FLOOR BUSES

## PRODUCT HIGHLIGHTS

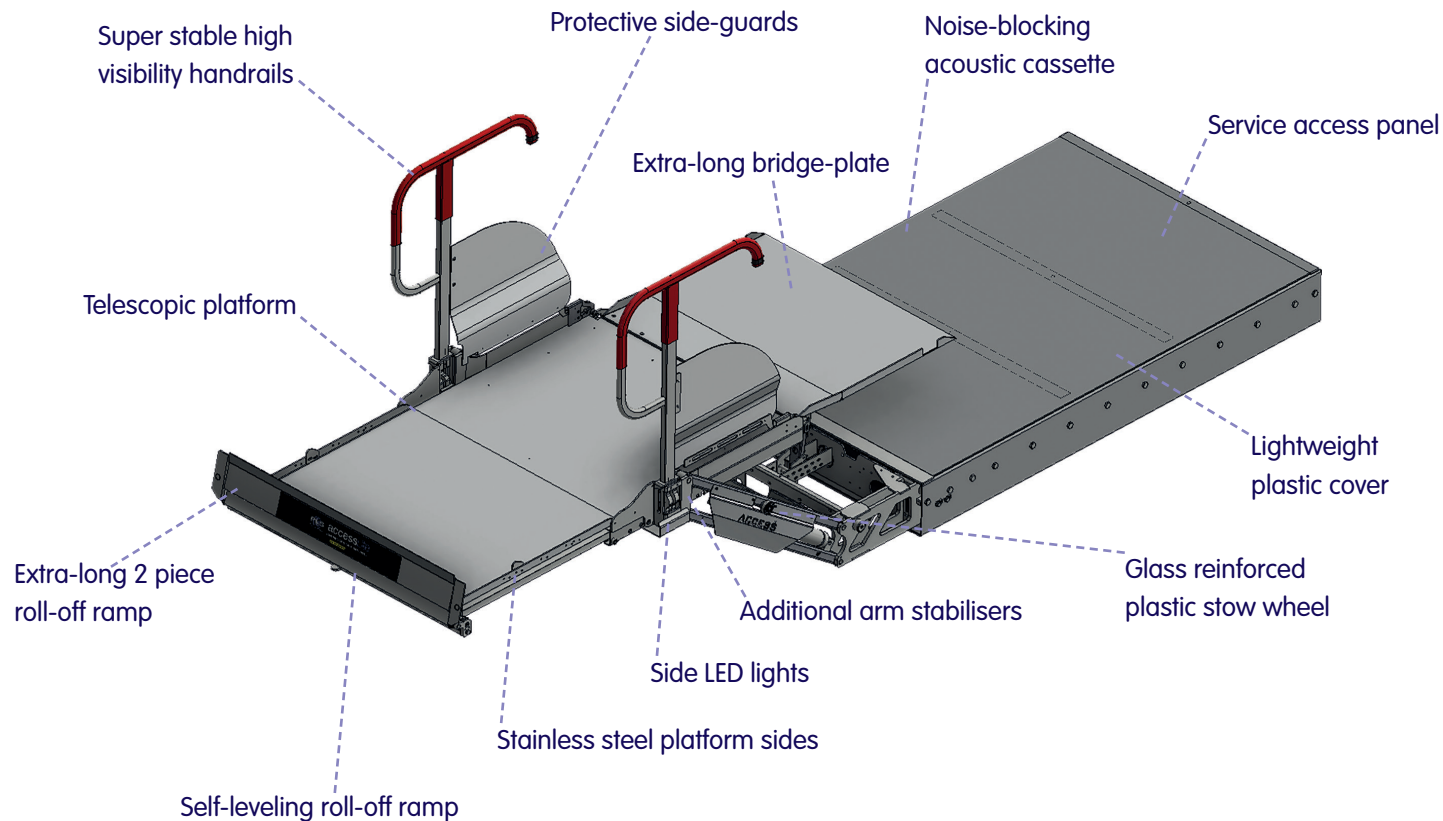

# ACCESS™ STEP-WELL CASSETTE LIFT FOR HIGH FLOOR BUSES

## TECHNICAL DATA

Access™ Step-Well	Technical Data	Benefits
Platform size	825/925mm (w) x 1410/1510/1610mm (l)	Semi-automatic
Cassette size	1000mm (w) x 1720mm (l) x 175mm (d)	Compatible with most high floor city bus designs
Max. lifting height	Up to 1250mm (Ground to vehicle floor)	Extra large and wide platform
Lift standard weight	235kg	Twin red rubber coated handrails
Lifting capacity (SWL)	300kg	High quality components

Access™ Step-Well Cassette Lift safety compliance.

- ✓ SWL and CE certificates issued
- ✓ LOLER Installation Compliance
- ✓ Fully PSVAR, DDA, COIF, SVTA and BS6109 Part 2 compliant
- ✓ Meets ECWVTA (European Whole Vehicle Type Approval)
- ✓ ISO accredited production



SCAN TO EXPERIENCE THE ACCESS™ STEP-WELL

# ACCESS™ STEP-WELL CASSETTE LIFT FOR HIGH FLOOR BUSES

## OPTIONAL FEATURES

Access™ Step-Well Lift options.

- ✓ Lifting capability upgrades
- ✓ Flashing or static LED warning lights
- ✓ Stainless steel anti-corrosion package
- ✓ Manual handrail/platform options available
- ✓ 2 x remote controllers that include illumination and or wireless operation
- ✓ Flush mounted door control option
- ✓ Box micro fitted to enable a correct stowage signal
- ✓ Additional handsets



EXTENDABLE HANDRAILS

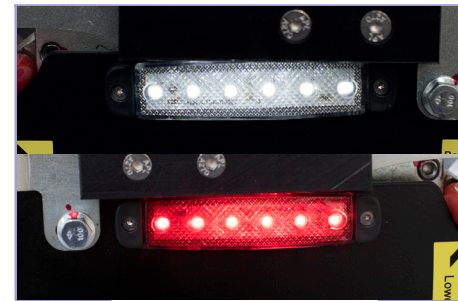

FLASHING LIGHTS

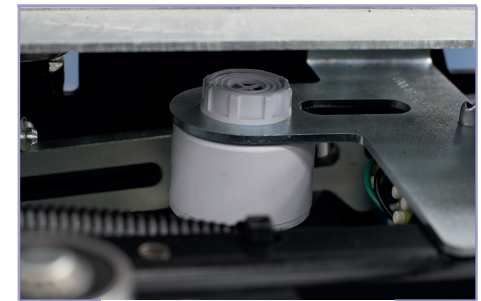

AUDIBLE WARNING DEVICE

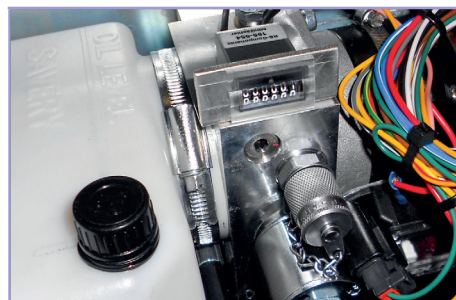

CYCLE COUNTER



REMOTE CONTROL



STOP SAFE ULTRA

ISO  
9001

EMC  
2014/30/EU

CE  
2006/42/EC

## CONTACT

12 Estuary View Business Park  
Whitstable | Kent | CT5 3SE  
United Kingdom

www.mobilitynetworksgroup.com

info@mobilitynetworksgroup.com

T+ 44 (0) 1227 505022  
F + 44 (0) 1227 505023

## COMPANY OVERVIEW

The Mobility Networks Group is a leading multi-national specialist in vehicle accessibility products. Our key mobility brands have been established for over 25 years with a continually expanding portfolio of vehicle access lifts, ramps, steps, seats, flooring and lowered floor conversion kits for all budgets and technical requirements.



## OUR HISTORY

- 2014 THE MOBILITY NETWORKS GROUP IS ESTABLISHED IN THE UK  
Rapidly expanding its operations internationally and acquiring new brands.
- 2004 ACDEOS BV IS FOUNDED IN THE NETHERLANDS  
Creating a wide European network of distributors for its range of ramps and steps.
- 1995 CAROIL SYSTEM SRL IS ESTABLISHED IN ITALY  
Becoming one of the leading European lift manufacturers.
- 1990 PLS (PASSENGER LIFT SERVICES) IS FOUNDED IN THE UK  
Becoming a market leader in wide range of cassette lifts.

## ACHIEVEMENTS



- ACDEOS MERGER 2017
- THE WIDEST MOBILITY RANGE 2017
- LEADER IN CASSETTE LIFTS 2017
- LEADER IN COACH LIFTS 2017
- CAROIL MERGER 2015
- PLS MERGER 2014

# THE MOBILITY WORLD

## VISION & PURPOSE

**"MOBILITY NETWORKS CREATE AND PRODUCE EQUIPMENT THAT FACILITATES AND SUPPORTS INDIVIDUALS TO GAIN GREATER FREEDOM"**

We achieve this by being a dependable partner to OEMs and Converters, offering the right products from basic to premium to our customers and distribution partners around the world.

## FIGURES

DOUBLE DIGIT GROWTH

50,000 + LIFTS SOLD

130 + EMPLOYEES

100S OF PRODUCTS



## LOCATIONS

- Mobility Networks - Global Headquarters  
Whitstable, Kent, United Kingdom
- PLS (Passenger Lift Services)  
Smethwick, Birmingham, United Kingdom
- Caroil System  
Palidano di Gonzaga, (Mn), Italy
- Acdeos BV  
Touwbaan, Leiderdorp, The Netherlands
- Mobility Networks Offices  
Canada, Denmark, Romania

## BRANDS

MOBILITY NETWORKS

PLS (PASSENGER LIFTS SERVICES)

CAROIL SYSTEM

ACDEOS

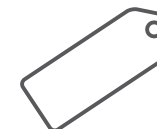

### HELPING YOU MAKE INFORMED DECISIONS

- Our Smart Range was created to promote the differences between each product group and help our customers make informed purchasing decisions. Visit our webpage to find out more about the Smart Premium, Smart + and Smart Basic product range.

